

### LEVA RULLO 3/2 1/8"

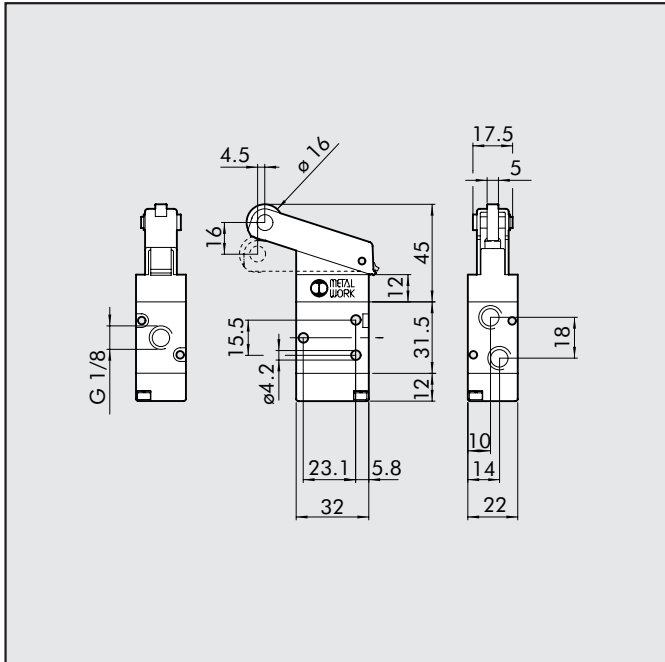

Simbolo	Sigla	Codice	Peso [g]
	MEV 23 BRS NC	7001000500	130

### LEVA RULLO 5/2 1/8"

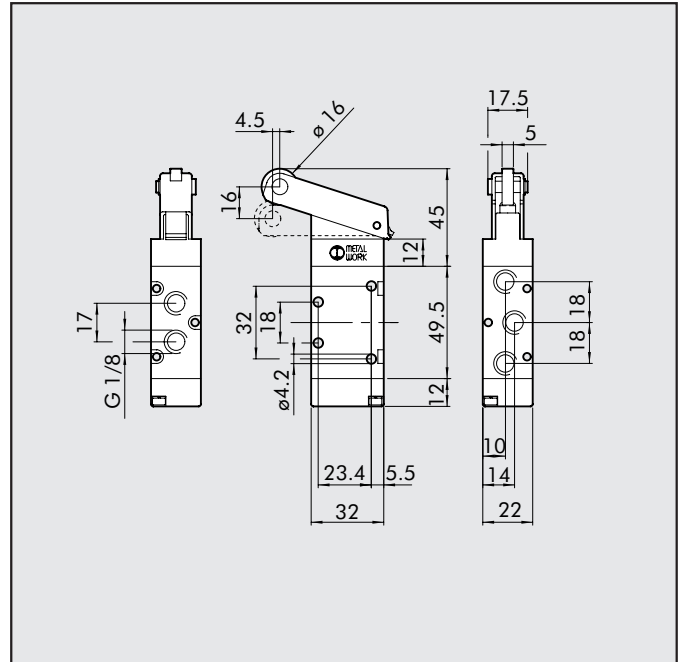

Simbolo	Sigla	Codice	Peso [g]
	MEV 25 BRS OO	7001000510	156

### LEVA RULLO UNIDIREZIONALE 3/2 1/8"

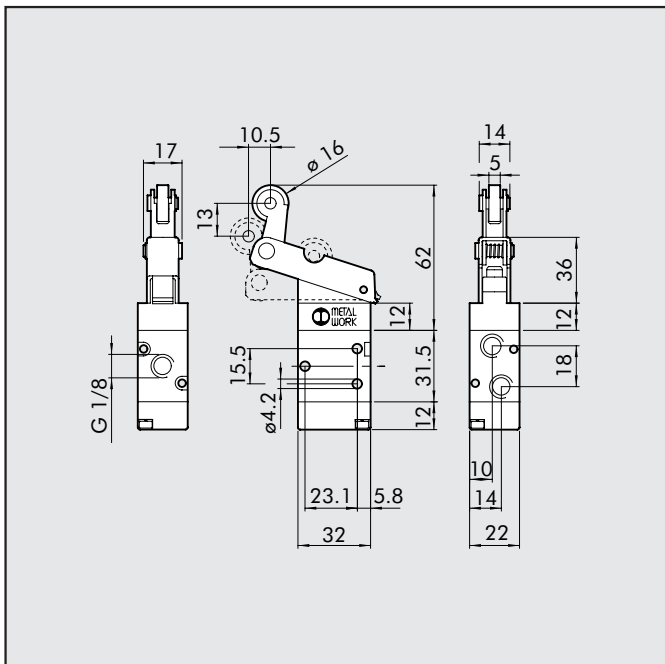

Simbolo	Sigla	Codice	Peso [g]
	MEV 23 URS NC	7001000600	136

### LEVA RULLO UNIDIREZIONALE 5/2 1/8"

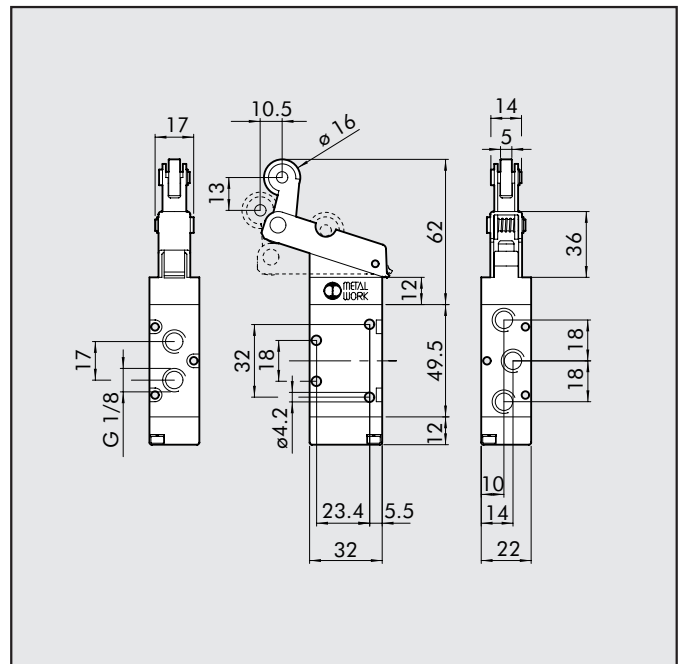

Simbolo	Sigla	Codice	Peso [g]
	MEV 25 URS OO	7001000610	162

**PUNTALE SERVOPILOTATO 3/2 NC 1/8"**

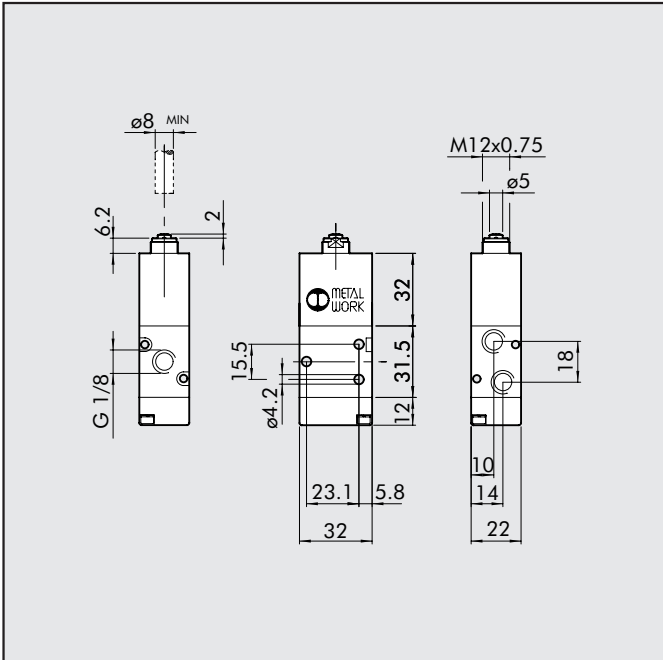

Simbolo	Sigla	Codice	Peso [g]
	MEV 23 TSS NC	7001000200	126

**PUNTALE SERVOPILOTATO 5/2 1/8"**

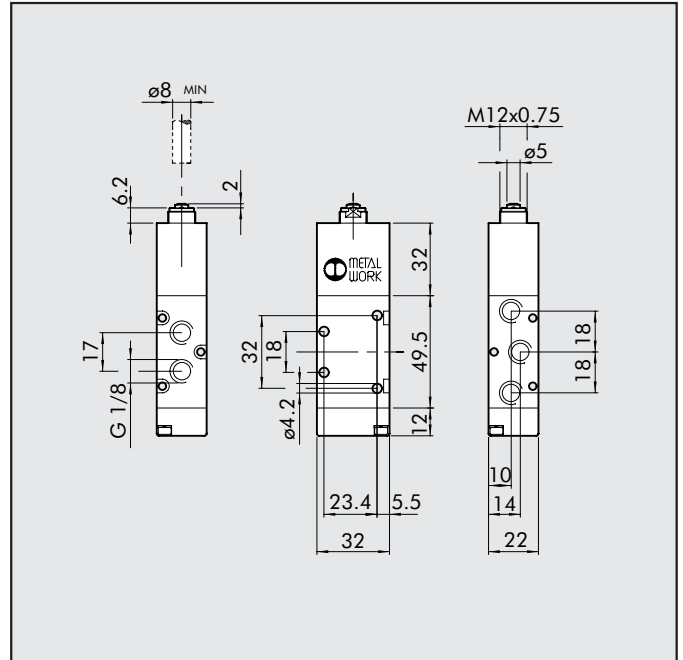

Simbolo	Sigla	Codice	Peso [g]
	MEV 25 TSS OO	7001000210	152

**LEVA RULLO SERVOPILOTATA 3/2 NC 1/8"**

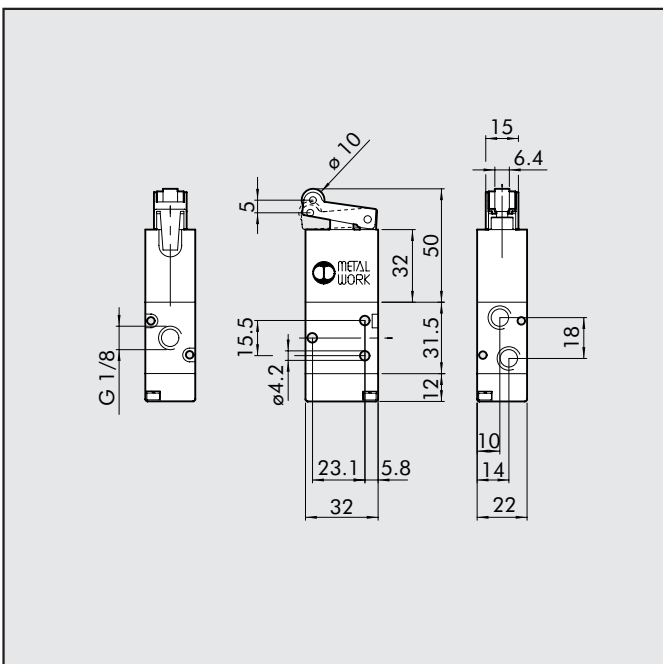

Simbolo	Sigla	Codice	Peso [g]
	MEV 23 RSS NC	7001000400	138

**LEVA RULLO SERVOPILOTATA 5/2 1/8"**

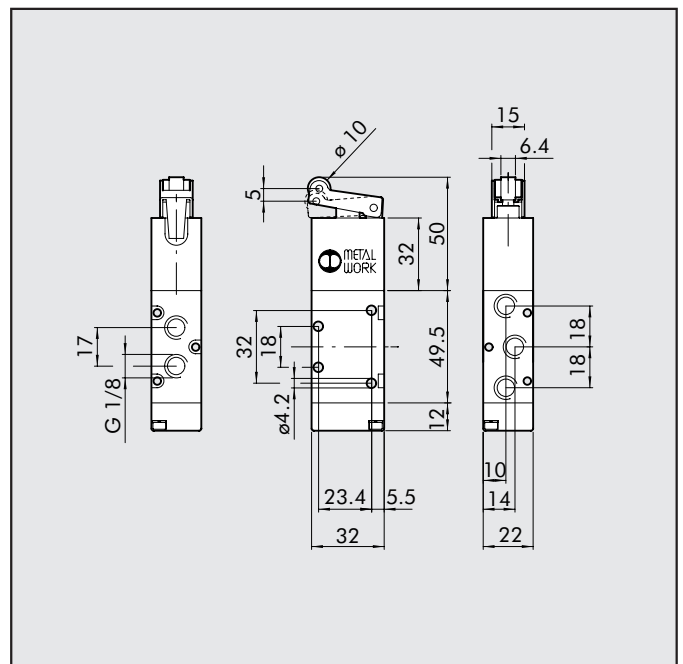

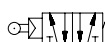
Simbolo	Sigla	Codice	Peso [g]
	MEV 25 RSS OO	7001000410	164

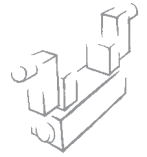

### ANTENNA SERVOPILOTATA 3/2 NC 1/8"

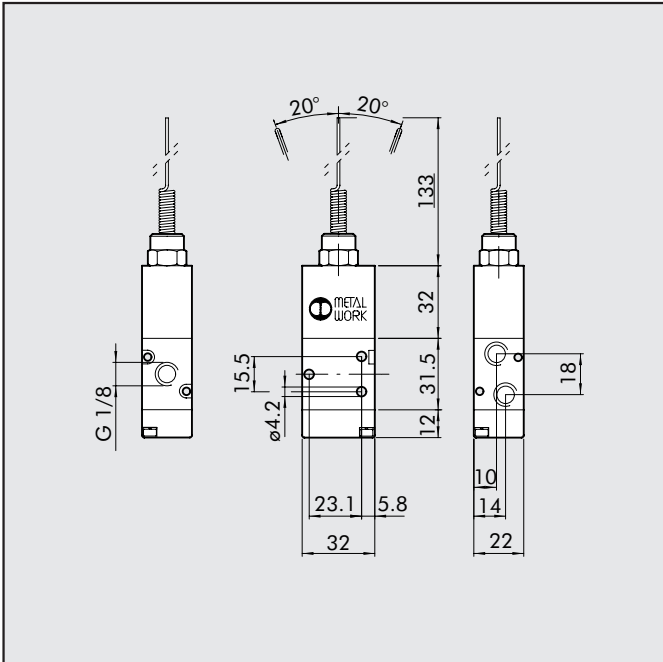

Simbolo	Sigla	Codice	Peso [g]
	MEV 23 ASS NC	7001000700	142

### ANTENNA SERVOPILOTATA 5/2 1/8"

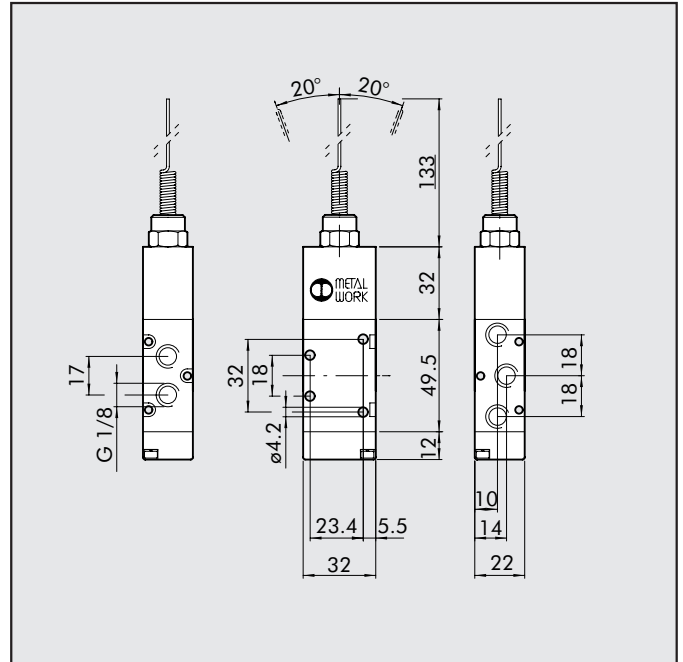

Simbolo	Sigla	Codice	Peso [g]
	MEV 25 ASS OO	7001000710	168

### LEVA RULLO 3/2 1/8"

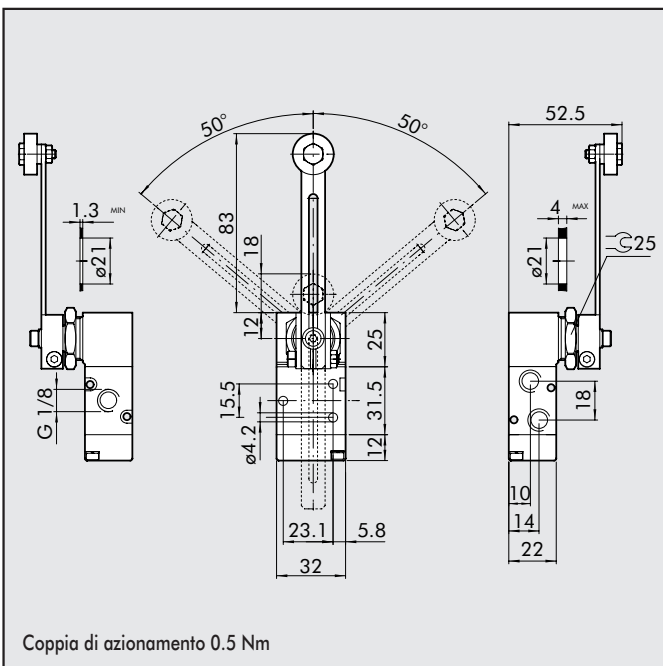

Coppia di azionamento 0.5 Nm

Simbolo	Sigla	Codice	Peso [g]
	MEV 23 LLS NC	7001000900	189

### LEVA RULLO 5/2 1/8"

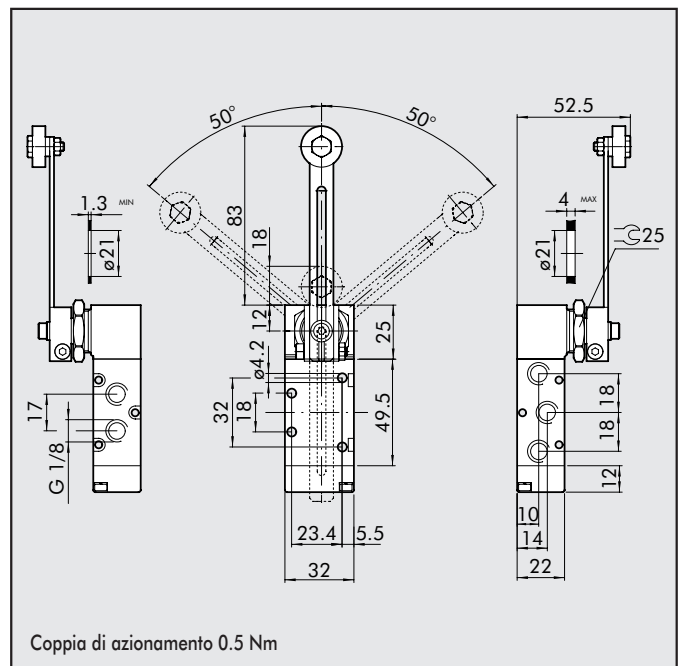

Coppia di azionamento 0.5 Nm

Simbolo	Sigla	Codice	Peso [g]
	MEV 25 LLS OO	7001000910	216