

PROPORTIONAL PRECISION PRESSURE REGULATOR "REGTRONIC 400" SERIES

Proportional pressure regulators series REGTRONIC have the job of precisely regulating the pressure in a system, the variables depending on the input command. The pressure value and a series of information and diagnostics are visible at all times on the graphic display. The user-display interface, LEDs and buttons are all on one side. The programming and reading software is comprehensive, simple and intuitive. Pressure control takes place in a "closed-loop" with an electronic precision pressure sensor that measures the downstream pressure, a control system that compares it with the desired pressure, and two mini solenoid valves that adjust the pressure to reach the target value. REGTRONIC 400 is characterized by a high feeding flow-rate.



TECHNICAL DATA		REGTRONIC 400
Fluid		Filtered, unlubricated air. The air must be filtered at at least 10 μm
MIN inlet pressure	bar	Regulation pressure +1 bar
MAX inlet pressure	bar	11
Temperature range	°C	0 ÷ 50
Pressure regulation range	bar	0.05 ÷ 10 (settable full scale and minimum pressure)
Flow rate at 6 bar ΔP 0.5	Nl/min	1" ÷ 1 1/2" = 18.000 2" = 20.000
Exhaust flow rate at 6 bar with 0.5 bar overpressure	Nl/min	850
Installation position		in any position
Weight	Kg	1" - 1 1/4" - 1 1/2" = 5 2" = 5.8
Class of protection		IP 65
Power supply		24 Vcc +10% -5% I max 110 mA
Input signal (input impedance)	Voltage	0 ÷ 5 Vcc, 0 ÷ 10 Vcc (approx. 1.68 KΩ)
	Current	4 ÷ 20 mA (approx. 100 KΩ)
	Serial ports	RS 232
	Manual	Keypad
Output signal	Analog	0 ÷ 10 Vcc (1 V=1bar) - 1 mA max
	Digital	PNP open collector output: max 24V 60 mA NPN open collector output: max 24V 60 mA
Linearity		≤ ± 0,5% (Full scale)
Hysteresis		≤ ± 0,2% (Full scale)
Repeatability		≤ ± 0,2% (Full scale)
Sensitivity/Dead-band		setting range 10 ÷ 100 mbar
Output pressure display	Accuracy	≤ ± 0,3% (Full scale)
	Unit of measurement	bar, Mpa, PSI
	Minimum resolution	0.01 bar - 0.001 MPa - 0.01 PSI
Analog output accuracy		≤ ± 0,4% (Full scale)
Temperature characteristics		max 2 mbar / °C
Response time with ΔP =1 bar and 100 cc volume	sec	0.4 (from 6 to 7 bar) / 0.95 (from 7 to 6 bar)

N.B.: The features shown refer to the static condition only. With air consumption on the output side, the pressure may vary.

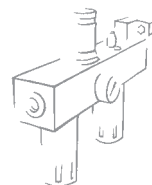

COMPONENTS

- ① Aluminium body
- ② Aluminium end plate
- ③ OT58 threaded bush, axial adjustment
- ④ OT58 brass retaining ring
- ⑤ Rolling diaphragm
- ⑥ OT58 brass plug
- ⑦ Stainless steel valve spring
- ⑧ OT58 brass stem with air relief hole
- ⑨ Valve with NBR vulcanized gasket
- ⑩ NBR gaskets
- ⑪ Connector M12 8 pin
- ⑫ Shell: technopolymer
- ⑬ Solenoid valve: 10 mm series PLT-10
- ⑭ Pressure sensor
- ⑮ Electronic boards

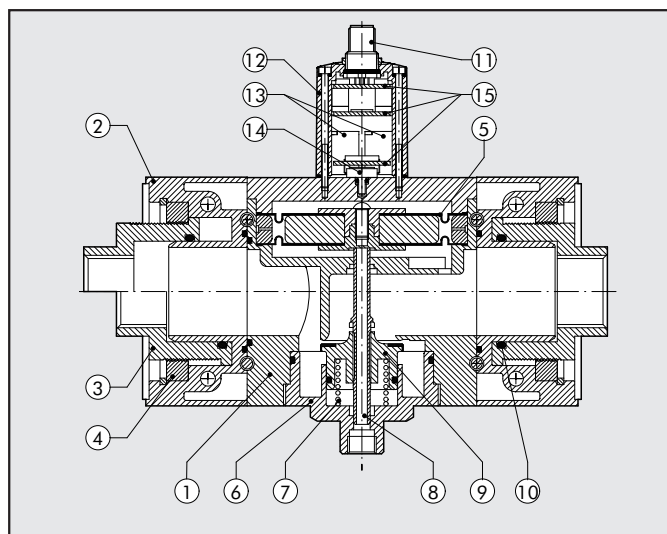

DIMENSIONS

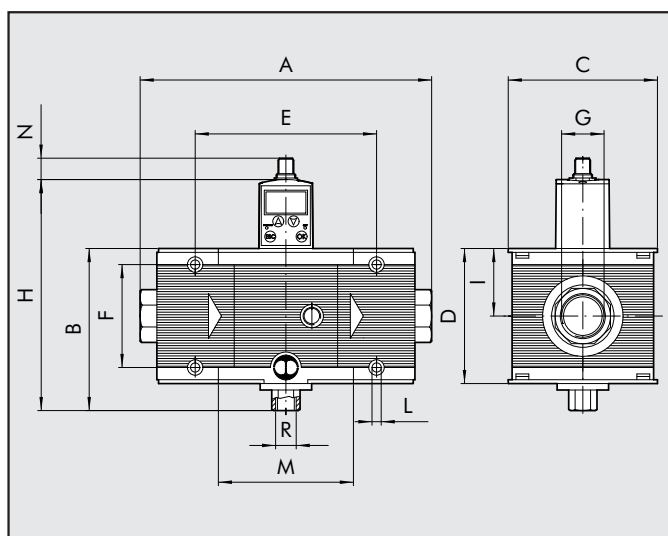

	REG 400 1"	REG 400 1 1/4"	REG 400 1 1/2"	REG 400 2"
A	225÷255			283÷313
B	127			
C	116			
D	105			
E	141.4			
F	80			
G	G 1"	G 1 1/4"	G 1 1/2"	G 2"
H	182			
I	52.5			
L	M6 hole			
M	105.4			
N	16.5			
P	G 1/4			
R	G 1/4			
Z				

ORDERING CODES

Code	Description
6102012A	REGTRONIC 400 WITHOUT EDN PLATES
6102012	REGTRONIC 400 1"
6202012	REGTRONIC 400 1 1/4"
6302012	REGTRONIC 400 1 1/2"
6402012	REGTRONIC 400 2"

FUNCTION DIAGRAM

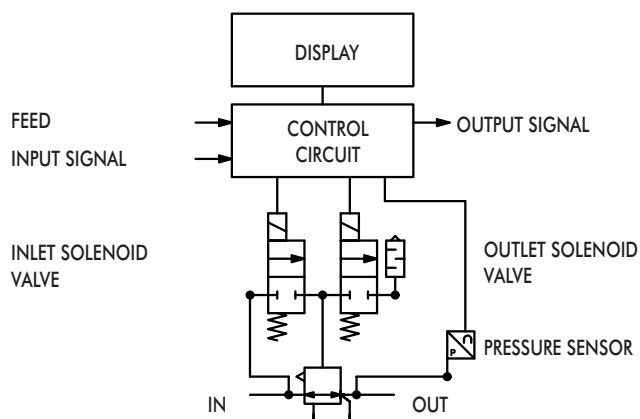

CONFIGURATION OF THE M12X1 8-PIN CONNECTOR

- | | |
|----------------------------------|----------|
| 1 = TX (RS232) | (WHITE) |
| 2 = RX (RS232) | (BROWN) |
| 3 = set 0-10 V / 0-5 V / 4-20 mA | (GREEN) |
| 4 = digital out 0-24 V NPN | (YELLOW) |
| 5 = analog out 0-10 V | (GREY) |
| 6 = digital out 0-24 V PNP | (PINK) |
| 7 = 0 V (GND) | (BLUE) |
| 8 = power supply +24V | (RED) |

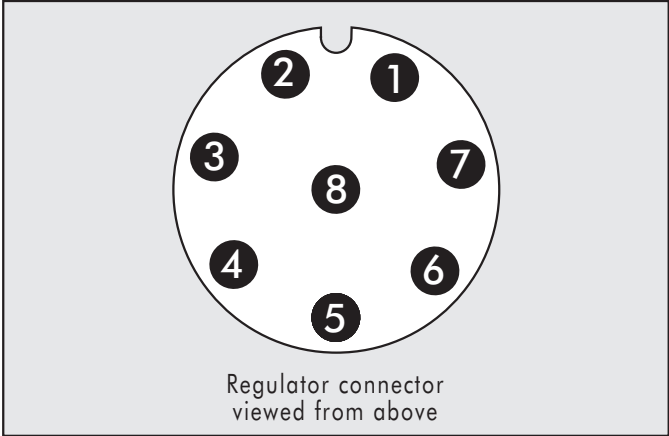

FLOW CHARTS

REGTRONIC 400 1" ÷ 1"1/2

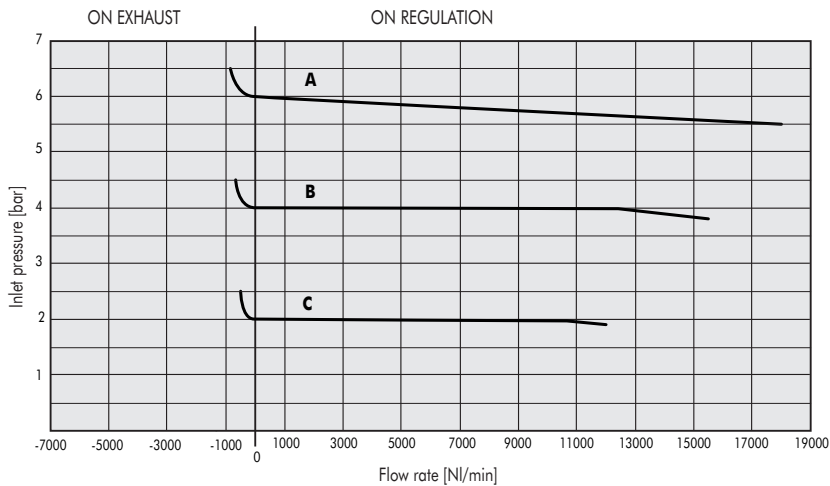

REGTRONIC 400 2"

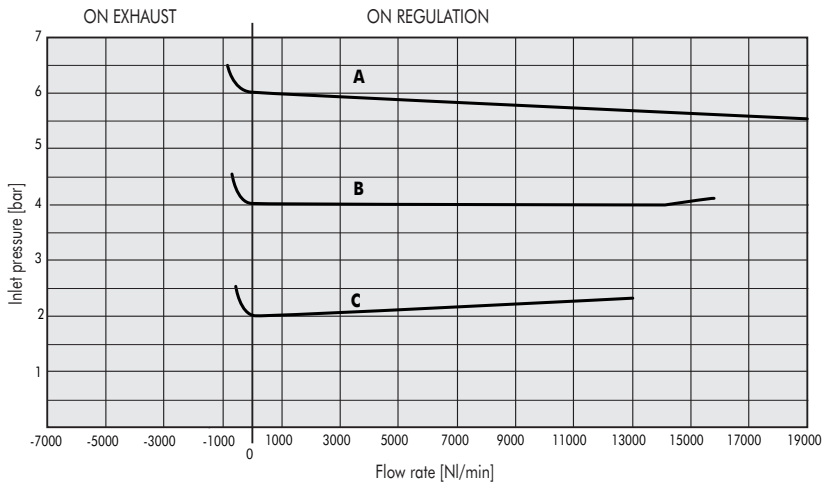

A = 2 bar B = 4 bar C = 4 bar Pm = 7 bar

