

CYLINDER SERIES "ISO 15552" (EX ISO 6431) Ø 32 ÷ 125 mm

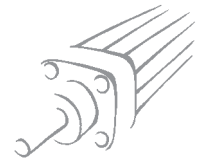

1

Cylinders made to ISO 15552 VDMA available in various versions and with a wide range of accessories:

- Configuration with or without magnet
- Single- or double-acting – single- or through-rod
- Wide choice of NBR, POLYURETHANE and FKM/FPM gaskets (for high temperatures)
- Special versions on request
- Fixing accessories, guide units and mechanical piston rod lock.

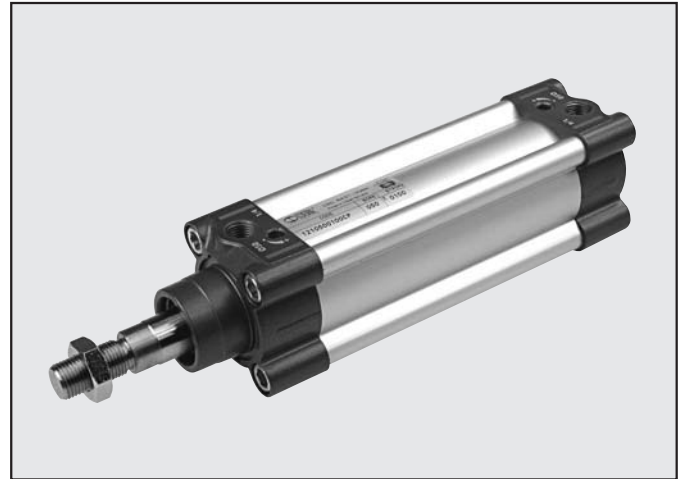

TECHNICAL DATA	Polyurethane	NBR	FKM/FPM	Low Temperature
Operating pressure	max 10 bar (max 1 MPa - 145 psi)			
Temperature range Ø 32 ÷ 63	-20°C to +80°C (non-magnetic cyl.) -20°C to +70°C (magnetic cyl.)	-10°C to +80°C (non-magnetic cyl.) -10°C to +70°C (magnetic cyl.)	-10°C to +150° (non-magnetic cyl.)	-35°C to + 80°C
Ø 80 ÷ 125	-10°C to +80°C (non-magnetic cyl.) -10°C to +70°C (magnetic cyl.)	-10°C to +80°C (non-magnetic cyl.) -10°C to +70°C (magnetic cyl.)	-10°C to +150° (non-magnetic cyl.)	-35°C to + 80°C
Fluid	Unlubricated air. Lubrication, if used, must be continuous			
Bore	Ø 32 ; Ø 40 ; Ø 50 ; Ø 63 ; Ø 80 ; Ø 100 ; Ø 125			
Design	Heads with Tap Tite screws			
Standard stroke †	Single-acting: for bores Ø 32-63, strokes 0-250 mm Double-acting: for bores Ø 32-80, strokes 25-2800 mm for bores Ø 100-125, strokes 25-2600 mm			
	† Maximum recommended strokes. Higher values can create operating problems			
Versions	Double-acting cushioned, Single-acting retracted piston rod cushioned, Through-rod cushioned, Long cushioning, High-temperature, Piston rod lock, Oil seal, Through-rod oil seal, Low friction, Non-stick-slip*.			
Sensor magnet	All versions come complete with magnet. Supplied without magnet on request.			
Inrush pressure	Ø 32; 40: 0.4 bar Ø 50;63 strokes < 1500 mm: 0.3 bar; strokes ≥ 1500 mm: 0.4 bar Ø 80;100;125 strokes < 1500 mm: 0.2 bar; strokes ≥ 1500 mm: 0.4 bar			
Forces generated at 6 bar thrust/retraction	See GENERAL TECHNICAL DATA PAGE 1.1/05			
Weights	See GENERAL TECHNICAL DATA PAGE 1.1/06			
	For no-stick slip versions use no-lubricated air only			

COMPONENTS

- ① PISTON ROD: C45 steel or stainless steel, thick chromed
- ② HEAD: die cast aluminium
- ③ PISTON ROD GASKET: polyurethane, NBR or FKM/FPM
- ④ GUIDE BUSHING: steel strip with bronze and PTFE insert
- ⑤ BARREL: drawn anodised calibrated aluminium
- ⑥ HALF-PISTON: self-lubricating technopolymer with built-in cushioning olives (aluminium with PTFE pad for diameters 80-100-125)
- ⑦ PISTON GASKET: polyurethane, NBR or FKM/FPM
- ⑧ MAGNET: plastoferrite
- ⑨ BUFFER + Static O-rings: NBR or FKM/FPM
- ⑩ CUSHIONING GASKET: polyurethane, NBR or FKM/FPM
- ⑪ CUSHIONING NEEDLE: OT 58 with needle out movement safety system even when fully open
- ⑫ SCREWS: Tap Tite for assembly

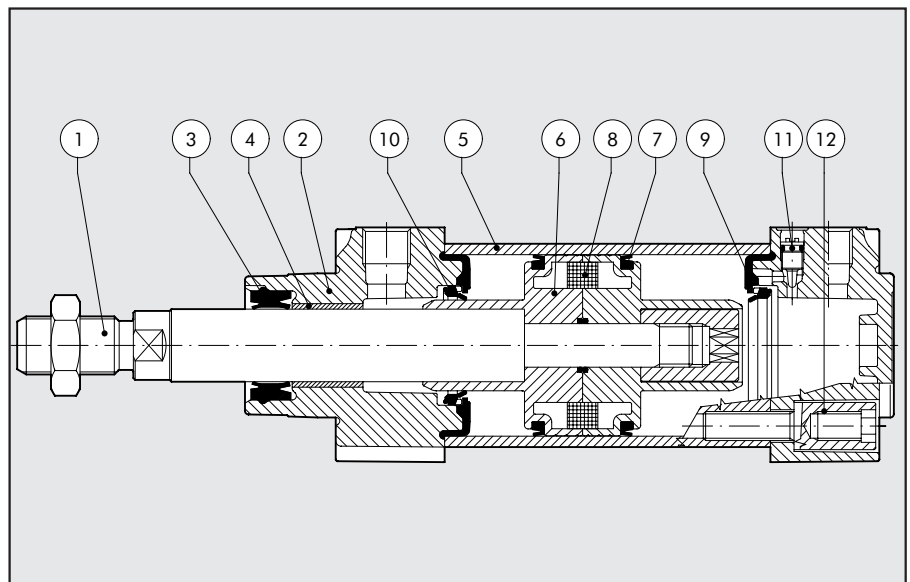

DIMENSIONS OF STANDARD VERSION

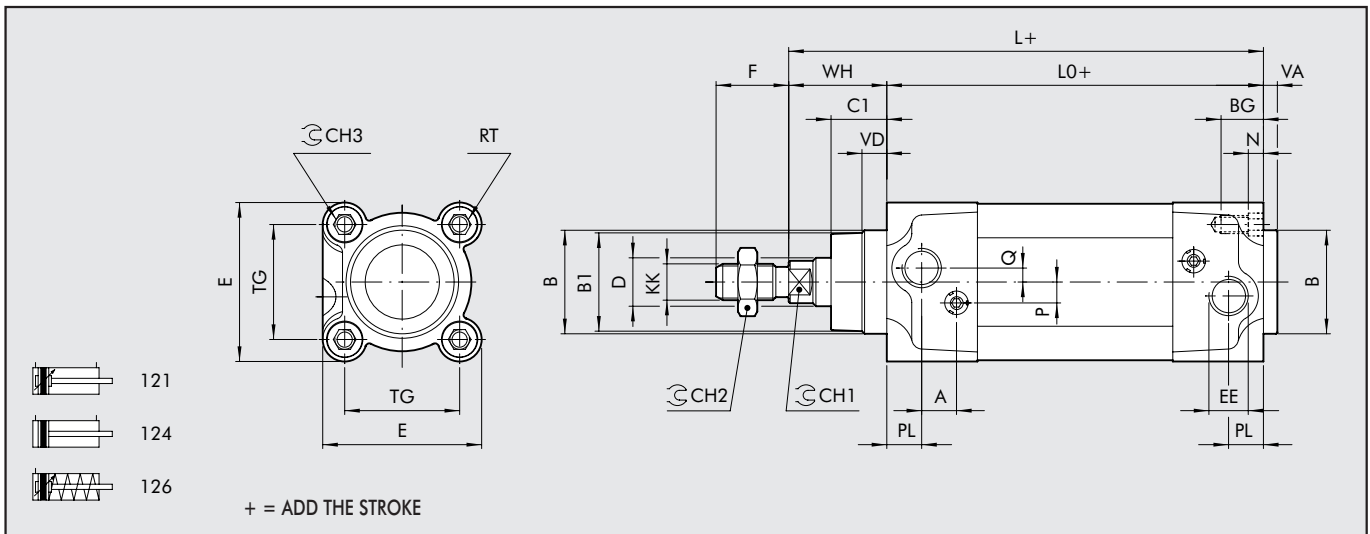

DIMENSIONS OF THROUGH-ROD VERSION

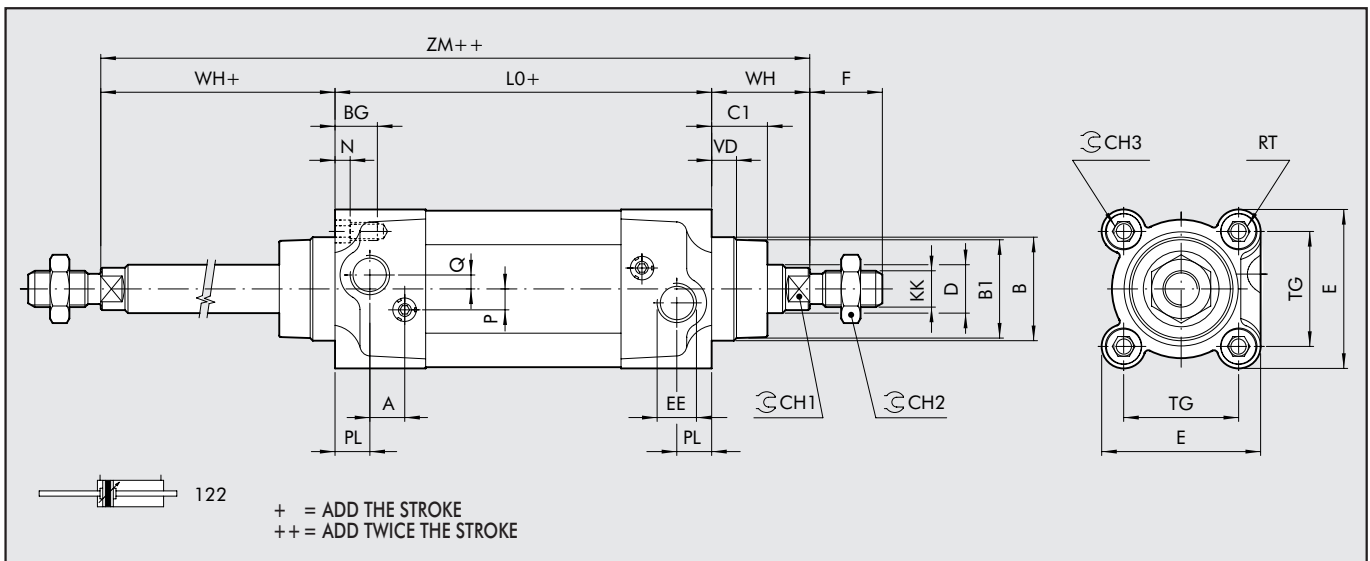

Ø	PL	VD	A	B	B ₁	WH	C ₁	CH ₁	CH ₂	CH ₃	KK	D	TG	VA	F	EE	RT	E	L	L ₀	ZM	BG	N	P	Q
32	10	6.5	10	30	28	26	16	10	17	6	M10x1.25	12	32.5	4	22	G1/8	M6	46	120	94	146	14.5	4.5	6	4
40	12	8	10	35	33	30	20	13	19	6	M12x1.25	16	38	4	24	G1/4	M6	54	135	105	165	14.5	4.5	6	4
50	14	13	10	40	38	37	25	17	24	8	M16x1.5	20	46.5	4	32	G1/4	M8	64.5	143	106	180	17.5	5.5	6	6
63	16	14	10	45	40	37	25	17	24	8	M16x1.5	20	56.5	4	32	G3/8	M8	75.5	158	121	195	17.5	5.5	6	6
80	18	12	12	45	43	46	33	22	30	10	M20x1.5	25	72	4	40	G3/8	M10	94	174	128	220	21.5	5.5	10	7
100	20	14	12	55	49	51	38	22	30	10	M20x1.5	25	89	4	40	G1/2	M10	111	189	138	240	21.5	5.5	10	7
125	25	20	10	60	54	65	45	27	41	12	M27x2	32	110	6	54	G1/2	M12	135	225	160	290	25.5	6.5	12	8

VERSION 126 (SINGLE-ACTING)

	Upper limit	Stroke	Lower limit	L0 - Ø 32	L0 - Ø 40	L0 - Ø 50	L0 - Ø 63	L - Ø 32	L - Ø 40	L - Ø 50	L - Ø 63
ISO	0	< C ≤	25	94	105	106	121	120	135	143	158
ISO	25	< C ≤	50	94	105	106	121	120	135	143	158
NON ISO	50	< C ≤	75	115	129.5	130.5	145.5	141	159.5	167.5	182.5
NON ISO	75	< C ≤	100	136	154	155	170	162	184	192	207
NON ISO	100	< C ≤	125	157	178.5	179.5	194.5	183	208.5	216.5	231.5
NON ISO	125	< C ≤	150	178	203	204	219	204	233	241	256
NON ISO	150	< C ≤	175	199	227.5	228.5	243.5	225	257.5	265.5	280.5
NON ISO	175	< C ≤	200	220	252	253	268	246	282	290	305
NON ISO	200	< C ≤	225	241	276.5	277.5	292.5	267	306.5	314.5	329.5
NON ISO	225	< C ≤	250	262	301	302	317	288	331	339	354



DIMENSIONS OF 100 mm CUSHIONING VERSION

1

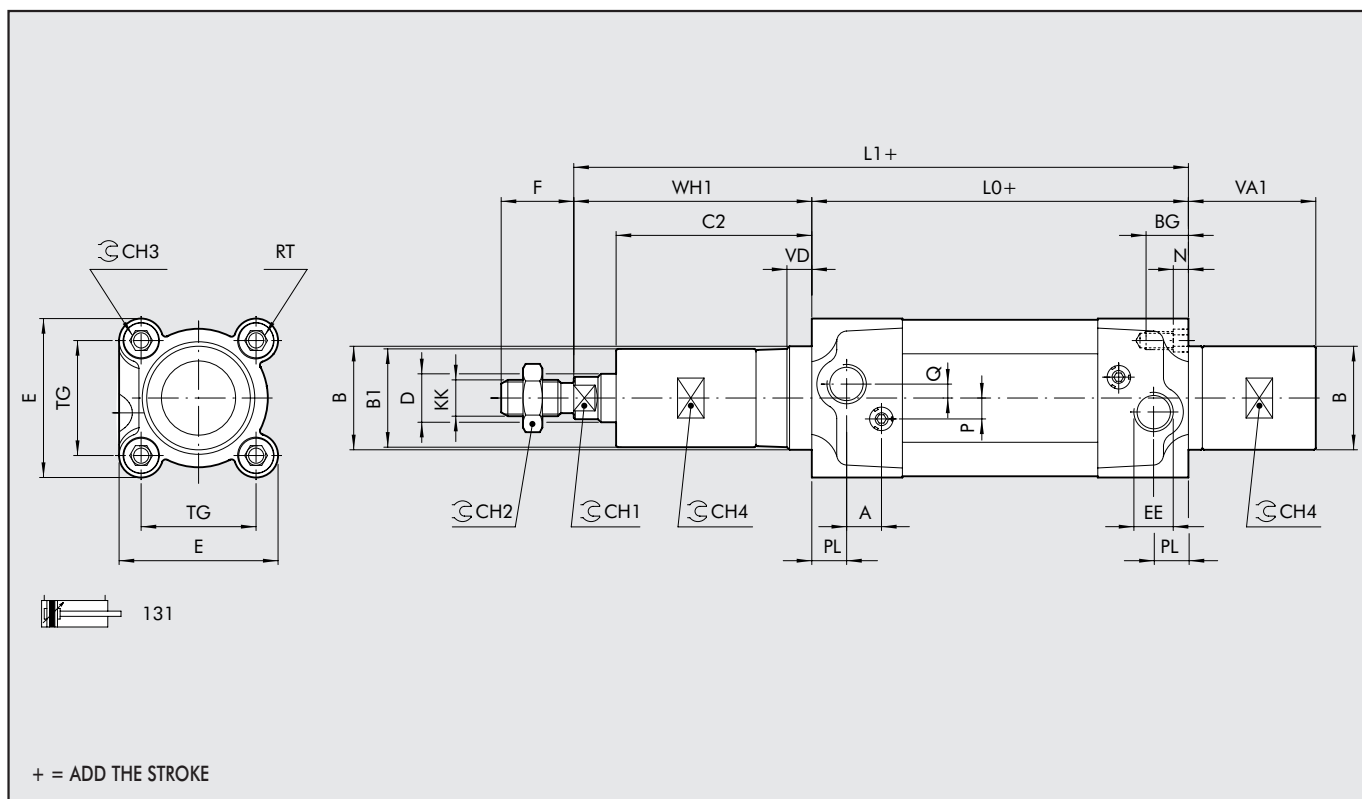

Ø	PL	VD	A	B	B ₁	WH ₁	C ₂	CH ₁	CH ₂	CH ₃	CH ₄	KK	D	TG	VA ₁	F	EE	RT	E	L ₁	L ₀	BG	N	P	Q
32	10	6.5	10	30	29	106	96	10	17	6	27	M10x1.25	12	32.5	79	22	G1/8	M6	46	200	94	14.5	4.5	6	4
40	12	8	10	35	34	107	97	13	19	6	30	M12x1.25	16	38	76.5	24	G1/4	M6	54	212	105	14.5	4.5	6	4
50	14	13	10	40	38	113.5	101.5	17	24	8	35	M16x1.5	20	46.5	76.5	32	G1/4	M8	64.5	219.5	106	17.5	5.5	6	6
63	16	14	10	45	38	113.5	101.5	17	24	8	35	M16x1.5	20	56.5	76.5	32	G3/8	M8	75.5	234.5	121	17.5	5.5	6	6

DIMENSIONS OF 150 mm CUSHIONING VERSION

DIMENSIONS OF 200 mm CUSHIONING VERSION

Ø	WH ₁	C ₂	VA ₁	L ₁
32	156	146	129	250
40	157	147	121.5	262
50	162.5	150.5	119.5	268.5
63	162.5	150.5	123.5	283.5

Ø	WH ₁	C ₂	VA ₁	L ₁
32	206	196	179	300
40	207	197	176.5	312
50	213.5	201.5	176.5	319.5
63	213.5	201.5	176.5	334.5

DIMENSIONS OF TANDEM VERSION

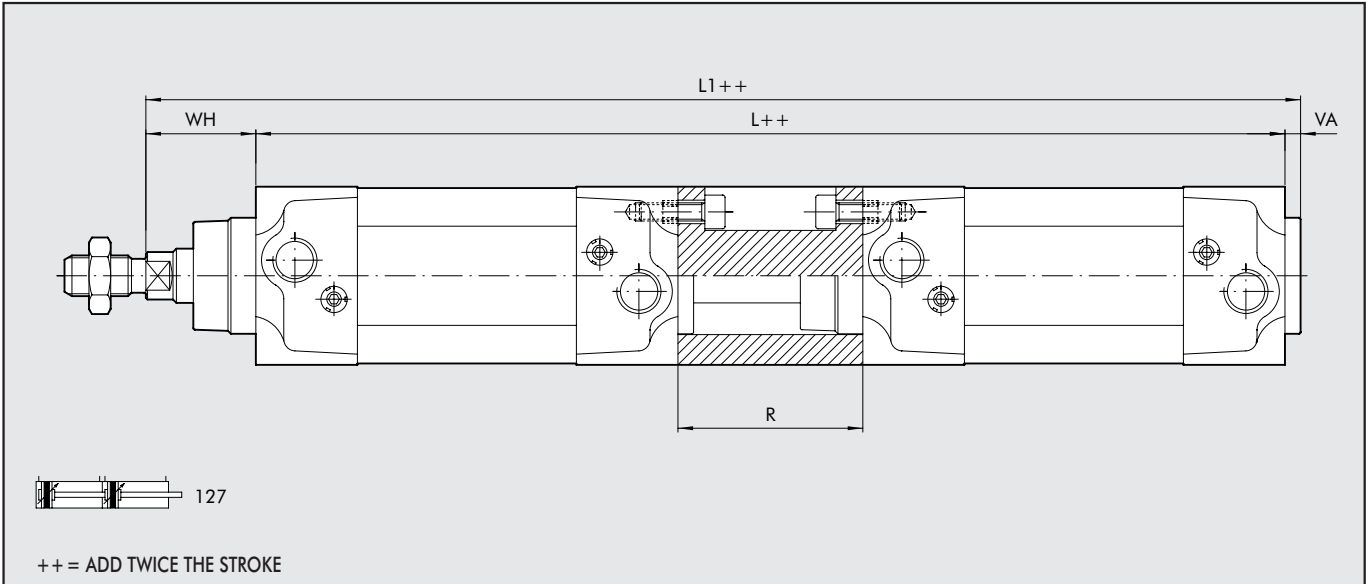

Ø	WH	VA	R	L	L ₁	
32	26	4	55	243	273	
40	30	4	55	265	299	
50	37	4	68	280	321	
63	37	4	68	310	351	
80	46	4	92	348	398	
100	51	4	92	368	423	
125	65	6	120	440	511	Refer to standard cylinders for other values.

DIMENSIONS OF OPPOSED VERSION

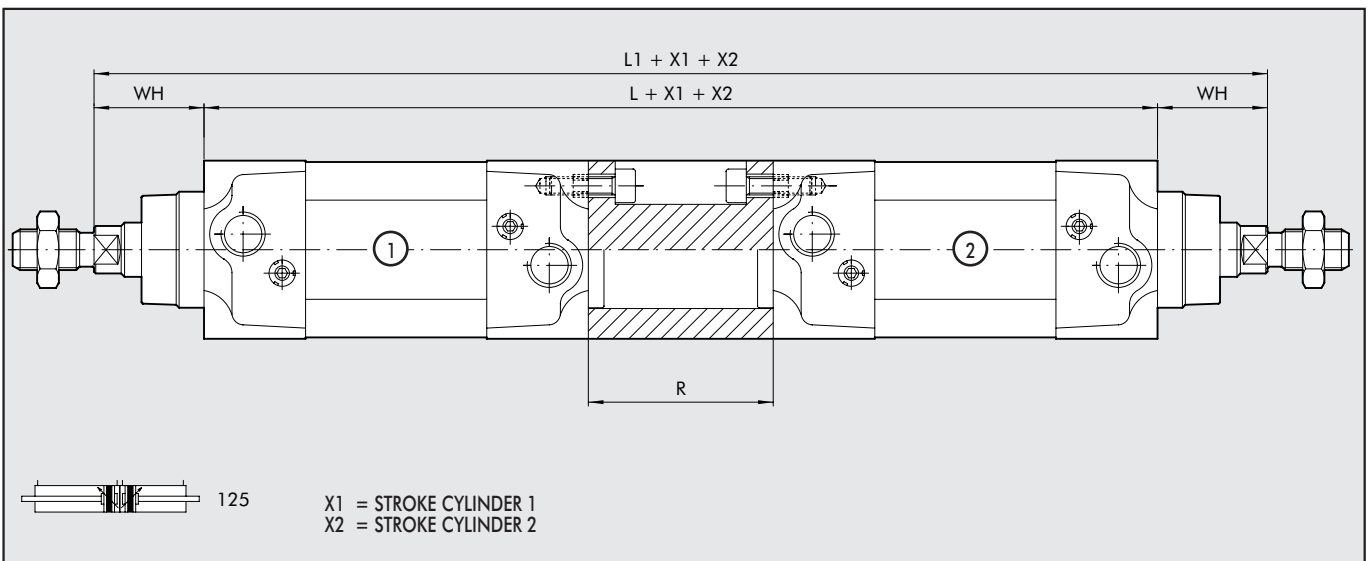

Ø	WH	R	L	L ₁	
32	26	55	243	295	
40	30	55	265	325	
50	37	68	280	354	
63	37	68	310	384	
80	46	92	348	440	
100	51	92	368	470	
125	65	120	440	570	Refer to standard cylinders for other values.

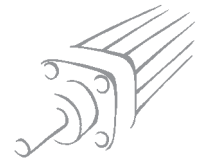

LOW-FRICTION VERSION – CODE 123

1

- ① Rear chamber piston gasket made of polyurethane (Ø 32-125);
- ② Front chamber piston gasket made of polyurethane (Ø 32-125);
- ③ Rear chamber cushioning gasket made of polyurethane;
- ④ Front chamber cushioning gasket made of polyurethane;
- ⑤ Piston rod gasket made of polyurethane.

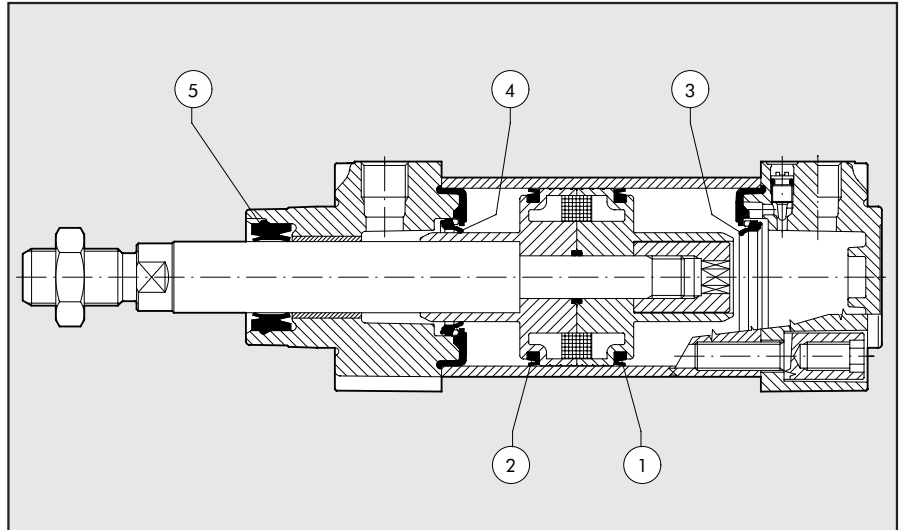

	Type	Gaskets
Rear chamber pressure	A	1
Rear chamber pressure and cushioning in case of impact	B	1+3
Rear chamber pressure and piston rod gasket	C	1+5
Rear chamber pressure, cushioning in case of impact and piston rod gasket	D	1+3+5
Front chamber pressure	E	2+5
Front chamber pressure and cushioning in case of impact	F	2+5+4

The low-friction cylinder is typically used as a dandy or tensioning cylinder since it is a single-acting cylinder without a return spring. The configurations are shown below:

- 1) The best type is A as it involves less friction.
- 2) Type B should be used when the cylinder is working under normal conditions outside the pneumatic cushioning area. Cushioning is only for emergency use. It acts as a shock absorber in the case of malfunction.
- 3) Type C differs from type A due to the presence of a piston rod gasket that prevents dirt getting in when operating in dirty environments.
- 4) Type D differs from type B due to the presence of a piston rod gasket that prevents dirt getting in when operating in dirty environments.
- 5) Type E should be used when the pressurized chamber is the front one.
- 6) For type F, see point 2.

NB. THE CYLINDER IS ALWAYS SINGLE-ACTING WITHOUT A RETURN SPRING.

NOTES

KEY TO CODES

ISO 15552 STD CYLINDER

CYL	1	2	1	0	3	2	0	0	5	0	C	P			
	TYPE			BORE		STROKE									
120	Double-acting, cushioned, non-magnetic			0	Diameter	32	For the maximum suppliable strokes, look at the technical data					A	C45 chromed rod, aluminium piston rod: standard for all cylinders with ≥ 1000 mm-stroke cylinders and for cylinder with $\varnothing 80$ mm and over	N	NBR gaskets
121	Double-acting, cushioned			S	Non-magnetic	40									
122	Through-rod			▲ G	No stick slip	63								V	FKM/FPM gaskets
124	Double-acting, non-cushioned					80									
125	Opposed					100					C	C45 chromed rod, technopolymer piston: standard for cylinders of $\varnothing 32$ to $\varnothing 63$ mm with < 1000 mm strokes	● B	low temperature	
+ 126	Single-acting					125									
127	Tandem														
134	Rod lock version										Z	Stainless steel piston rod and nut aluminium piston			
136	Version with piston rod lock										X	Stainless steel piston rod and nut technopolymer piston			
◆ 137	Piston rod lock + guide unit														

- In the code of cylinder with letter in fourth position $\varnothing 100$ becomes A1; $\varnothing 125$ becomes A2
- Only available for versions with aluminium piston (A or Z)
- + Available until $\varnothing 63$ and only the versions with piston in aluminum (A or Z)
- ▲ Not available for NBR (N) versions
- ◆ Available up to $\varnothing 100$

ISO 15552 LOW-FRICTION CYLINDER

CYL	1	2	3	A	3	2	0	0	5	0	C	P		
	TYPE			DIAMETER		STROKE								
A	Low friction, type A			32		$\varnothing 32 \div \varnothing 80$ stroke 25÷2800 mm					A	C45 chromed rod, aluminium piston rod: standard for all cylinders with ≥ 1000 mm-stroke cylinders and for cylinder with $\varnothing 80$ mm and over	N	NBR gaskets
B	Low friction, type B			40										
C	Low friction, type C			50		$\varnothing 100 \div \varnothing 125$ stroke 25÷2600 mm							V	FKM/FPM gaskets
D	Low friction, type D			63										
E	Low friction, type E			80							C	C45 chromed rod, technopolymer piston: standard for cylinders of $\varnothing 32$ to $\varnothing 63$ mm with < 1000 mm strokes		
F	Low friction, type F			A1= $\varnothing 100$ A2= $\varnothing 125$							Z	Stainless steel piston rod and nut aluminium piston		
											X	Stainless steel piston rod and nut technopolymer piston		

ISO 15552 LONG-CUSHIONING CYLINDER

CYL	1	3	1	A	3	2	0	0	5	0	C	P		
	TYPE			DIAMETER		STROKE								
A	200 mm front/rear cushioning cone – 200mm ext.			32		25÷2600 mm					A	C45 chromed rod, aluminium piston rod for all sizes	N	NBR gaskets
B	150 mm front/rear cushioning cone – 150mm ext.			40										
C	100 mm front/rear cushioning cone – 100mm ext.			50							Z	Stainless steel piston rod and nut aluminium piston	V	FKM/FPM gaskets
D	150 mm front/rear cushioning cone – 200mm ext.			63										
E	100 mm front/rear cushioning cone – 200mm ext.													
F	50 mm front/rear cushioning cone – 100mm ext.													
G	100 mm front/rear cushioning cone – 150mm ext.													
H	200 mm front cushioning cone – 200 mm ext.													
I	150 mm front cushioning cone – 150 mm ext.													
L	100 mm front cushioning cone – 100 mm ext.													
M	150 mm front cushioning cone – 200 mm ext.													
N	100 mm front cushioning cone – 150 mm ext.													
O	50 mm front cushioning cone – 100 mm ext.													
Q	200 mm rear cushioning cone – 200 mm ext.													
R	150 mm rear cushioning cone – 150 mm ext.													
S	100 mm rear cushioning cone – 100 mm ext.													
T	150 mm rear cushioning cone – 200 mm ext.													
U	100 mm rear cushioning cone – 200 mm ext.													
V	50 mm rear cushioning cone – 100 mm ext.													



ACCESSORIES: FIXINGS

INTERMEDIATE HINGE - MODEL EN

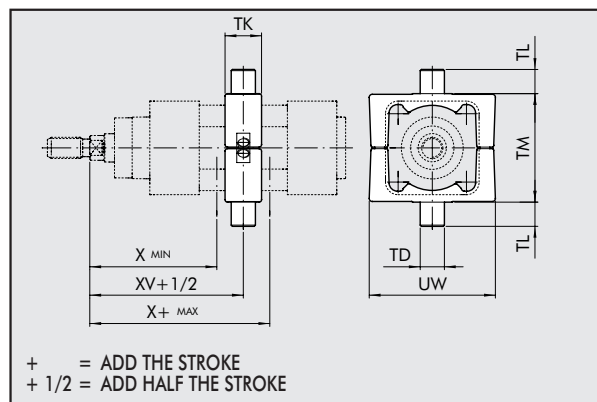

Code	Ø	X _(min)	XV	X _(max)	TM	TL	TD _{e9}	TK	UW	Weight [g]
0950322007	32	63	73	83	50	12	12	22	65	282
0950402007	40	72	82.5	93	63	16	16	28	75	582
0950502007	50	83	90	97	75	16	16	32	95	880
0950632007	63	86.5	97.5	108.5	90	20	20	35	105	1230
0950802007	80	104	110	116	110	20	20	40	130	2030
0951002007	100	113.5	120	126.5	132	25	25	45	145	2600
0951252007	125	135	145	155	160	25	25	50	175	3900

Note: Supplied complete with 4 grub screws, 2 pins

COUNTER-HINGE FOR MODEL EN - MODEL EL

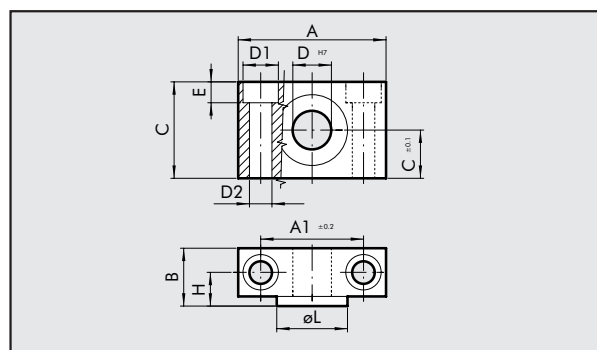

Code	Ø	A	A ₁	B	C	C ₁	D ₁	D ₂	D	E	H	ØL	Weight [g]
W0950322009	32	46	32	18	30	15	11	7	12	6.5	10.5	22	162
W0950402009	40	55	36	21	36	18	15	9	16	8.5	12	28	278
W0950402009	50	55	36	21	36	18	15	9	16	8.5	12	28	278
W0950632009	63	65	42	23	40	20	18	11	20	10.5	13	35	414
W0950632009	80	65	42	23	40	20	18	11	20	10.5	13	35	414
W0951002009	100	75	50	28.5	50	25	20	13	25	12.5	16	40	715
W0951002009	125	75	50	28.5	50	25	20	13	25	12.5	16	40	715

Note: Supplied with 4 securing screws

FIXING BRACKET SERIES KCV

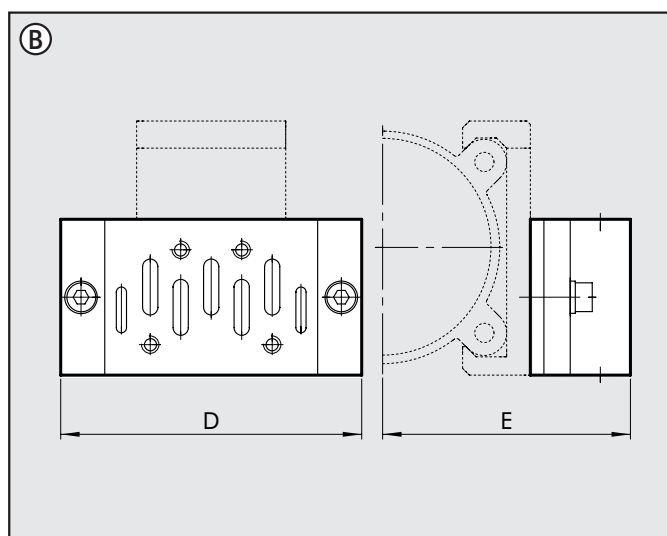
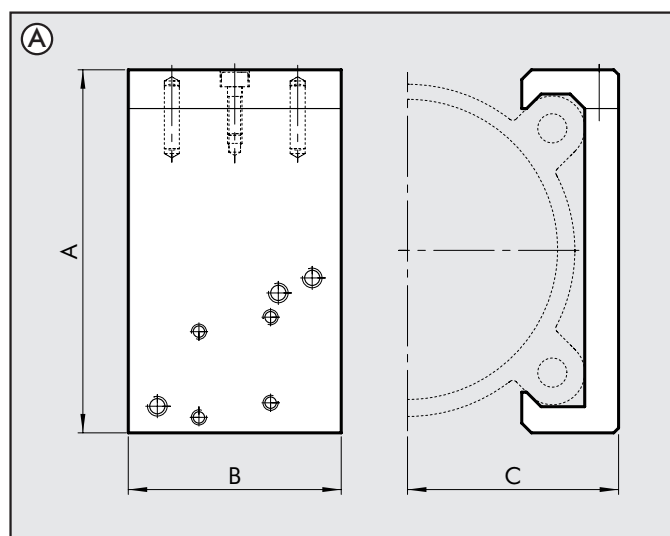

VALVE FIXING BRACKET - CYLINDER (Fig. A)

Code	Ø	A	B	C	ISO 1		ISO 2		Applicable valves	Weight [g]
					D	E	D	E		
0950322090	Ø 32	54	40	29.5	110	64.5	124	70.5	MACH 16 Series 70 1/8-1/4 ISO 1 - ISO 2	80
0950402090	Ø 40	59.5	40	32.2	110	67.2	124	73.2	MACH 16 Series 70 1/8-1/4 ISO 1 - ISO 2	86
0950502090	Ø 50	71.5	40	37	110	72	124	78	MACH 16 Series 70 1/8-1/4 ISO 1 - ISO 2	93
0950632090	Ø 63	81.5	40	42	110	77	124	83	MACH 16 Series 70 1/8-1/4 ISO 1 - ISO 2	101
0950802090	Ø 80	99	60	53.5	110	88.5	124	94.5	Series 70 1/8-1/4-1/2 ISO 1 - ISO 2	222
0951002090	Ø 100	119.5	60	63.5	110	98.5	124	104.5	Series 70 1/8-1/4-1/2 ISO 1 - ISO 2	258
0951252090	Ø 125	148	60	76.5	110	111.5	124	117.9	Series 70 1/8-1/4-1/2 ISO 1 - ISO 2	298

KIT FOR FIXING VALVES TO BRACKETS

Code	Valve kit	Composition	Weight [g]
0950002003	MACH 16	2 HEX. SCREWS M3x25 with WASHER	4
0950002004	Series 70 1/8-1/4	2 HEX. SCREWS M4x50 with WASHER	8
0950002006	Series 70 1/2	2 HEX. SCREWS M5x50 with WASHER	20
0950002001	ISO 1	ADAPTOR + ISO1 BASE SIDE + SCREWS + WASHERS (Fig. B)	230
0950002002	ISO 2	ADAPTOR + ISO 2 BASE SIDE + SCREWS + WASHERS (Fig. B)	350

VALVE ASSEMBLY ON CYLINDER

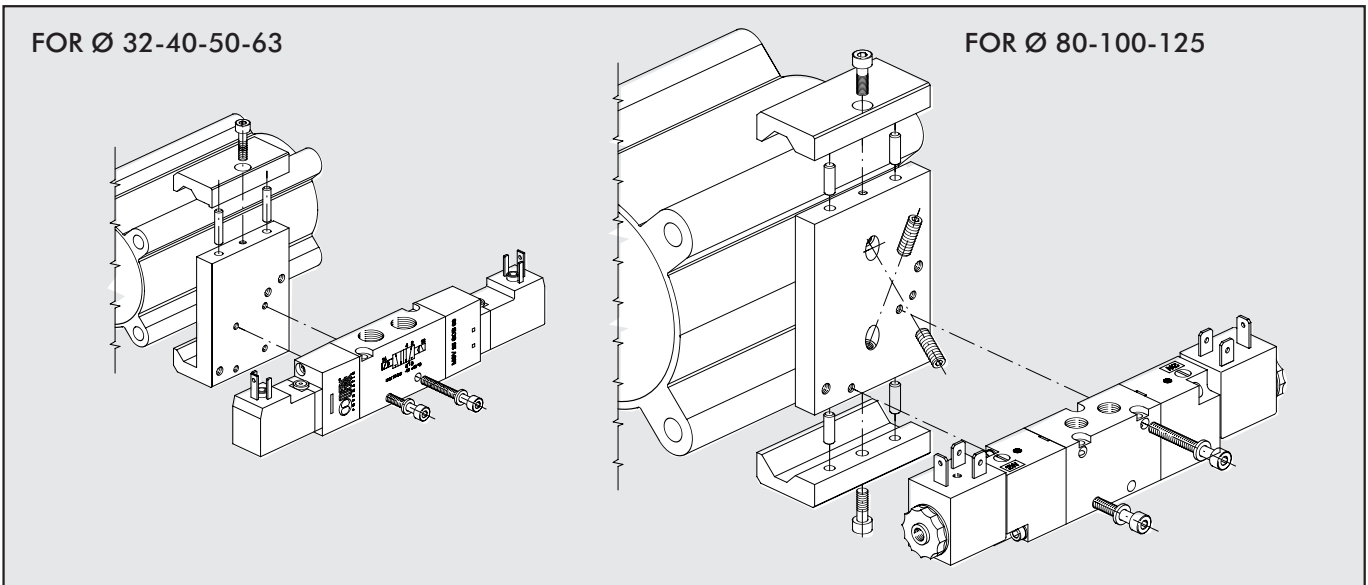

ACCESSORIES: MAGNETIC SENSORS

ORDERING CODES

Code	Description
W0950000201	REED SENSOR ACC. DSM2-C525 HS
W0950000222	E.HALL PNP SENSOR ACC. DSM3-N225
W0950000232	E. HALL NPN SENSOR ACC. DSM3-M225

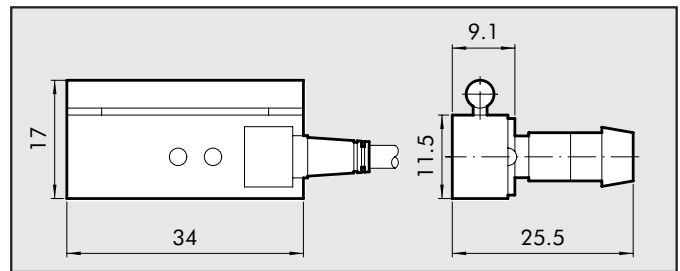

SENSOR SUPPORT BRACKETS

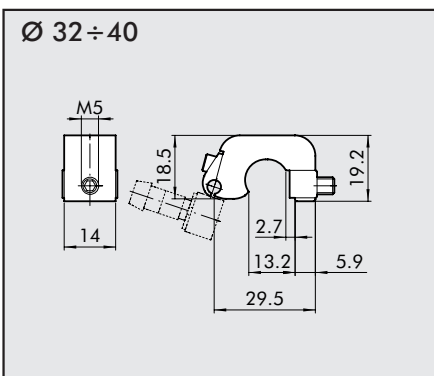

Code	Description
W0950000711	BRACKET ACC. D.32 DST 80

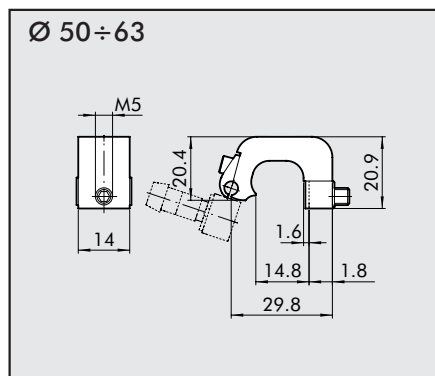

Code	Description
W0950000712	BRACKET ACC. D.50 DST 81

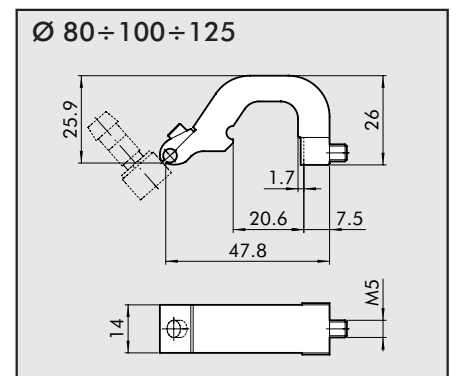

Code	Description
W0950000713	BRACKET ACC. D.80-100-125 DST 82



TECHNICAL DATA

Type		REED + VARISTORE + LED 2 fili	HALL VERSION PNP/NPN 3 wires
Contact		REED + VARISTORE + LED N.O.	HALL EFFECT NO PNP/NPN
Max AC/DC voltage	V	3 ÷ 48 V(DC); 3 ÷ 220 (AC)	6-24 V DC
Max current at 25°C	mA	500	250
Power with inductive load	VA	10	-
Power with resistive load	Watt	50	6
Switch-on time	m sec	1.2	0.8
Switch-off time	m sec	0.1	3
Switch-on point	Gauss	110	15
Switch-off point	Gauss	95	8
Operating life	-	10 ⁷ impuls	10 ⁹ impulses
Contact resistance		0.1	-
Cable length	m	2.5	2.5
Cable cross section	mm ²	0.35	0.35
Cable material		PVC Morbido	Soft PVC
Circuit			

DC

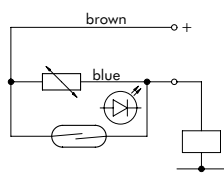

AC

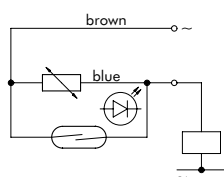

Version NPN

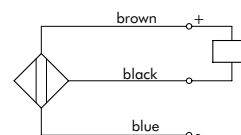

Version PNP

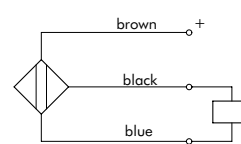

ADAPTOR FOR RETRACTABLE SENSOR

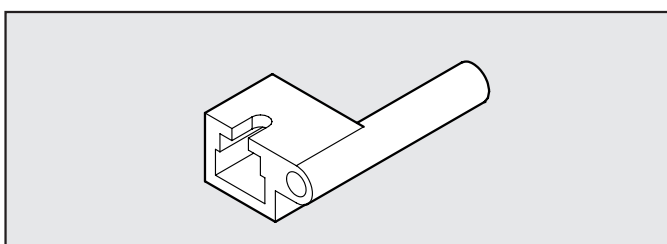

Code	Description
W0950001001	Adaptor DSS005 for DST/ST brackets

ASSEMBLY DIAGRAM

- ① ISO 15552 cylinder with traditional barrel
- ② Sensor bracket mod. DST (Ø32 ÷ 125)
- ③ Adaptor
- ④ Retractable sensor with insertion from above
- ⑤ Retractable sensor

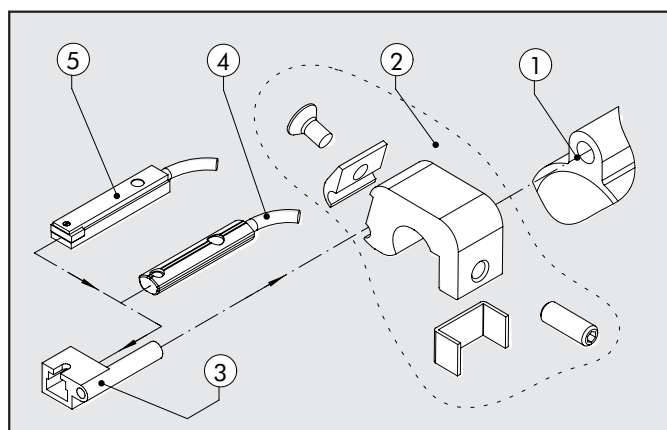

CYLINDERS SERIES "ISO 15552" (EX ISO 6431) $\varnothing 32 \div 125$ mm TYPE "A" RETRACTABLE SENSOR

The sensor can be inserted from the side thanks to the new shape of the heads. The profiles of the liners have been redesigned and the new shape means that dedicated intermediate hinges can be applied. Cylinders available in various versions and a wide range of accessories:

- Configuration with or without magnet
- Single- or double-acting – single- or through-rod
- Wide choice of NBR, POLYURETHANE and FKM/FPM gaskets (for high temperatures)
- Special versions on request
- Fixing accessories, guide units and mechanical piston rod lock.



TECHNICAL DATA	Polyurethane	NBR	FKM/FPM	Low Temperature
Operating pressure	max 10 bar (max 1 MPa - 145 psi)			
Temperature range $\varnothing 32 \div 63$	-20°C to +80°C (non-magnetic cyl.) -20°C to +70°C (magnetic cyl.)	-10°C to +80°C (non-magnetic cyl.) -10°C to +70°C (magnetic cyl.)	-10°C to +150° (non-magnetic cyl.)	-35°C \pm +80°C
$\varnothing 80 \div 125$	-10°C to +80°C (non-magnetic cyl.) -10°C to +70°C (magnetic cyl.)	-10°C to +80°C (non-magnetic cyl.) -10°C to +70°C (magnetic cyl.)	-10°C to +150° (non-magnetic cyl.)	-35°C \pm +80°C
Fluid	Unlubricated air. Lubrication, if used, must be continuous			
Bore	$\varnothing 32$; $\varnothing 40$; $\varnothing 50$; $\varnothing 63$; $\varnothing 80$; $\varnothing 100$; $\varnothing 125$			
Design	Heads with Tap Tite screws			
Standard stroke \ddagger	Single-acting: for bores $\varnothing 32$ -63, strokes 0-250 mm Double-acting: for bores $\varnothing 32$ -80, strokes 25-2800 mm for bores $\varnothing 100$ -125, strokes 25-2600 mm			
Versions	\ddagger Maximum recommended strokes. Higher values can create operating problems Double-acting cushioned, Single-acting retracted piston rod cushioned, Through-rod cushioned, Long cushioning, High-temperature, Piston rod lock, Oil seal, Through-rod oil seal, Low friction, Non-stick-slip*.			
Sensor magnet	All versions come complete with magnet. Supplied without magnet on request.			
Inrush pressure	$\varnothing 32$; 40: 0.4 bar $\varnothing 50$; 63 strokes < 1500 mm: 0.3 bar; strokes \geq 1500 mm: 0.4 bar $\varnothing 80$; 100; 125 strokes < 1500 mm: 0.2 bar; strokes \geq 1500 mm: 0.4 bar			
Forces generated at 6 bar thrust/retraction	See GENERAL TECHNICAL DATA PAGE 1.1/05			
Weights	See GENERAL TECHNICAL DATA PAGE 1.1/06			
	*For no-stick versions, use no-lubricated air only			

JACKET CROSS SECTION

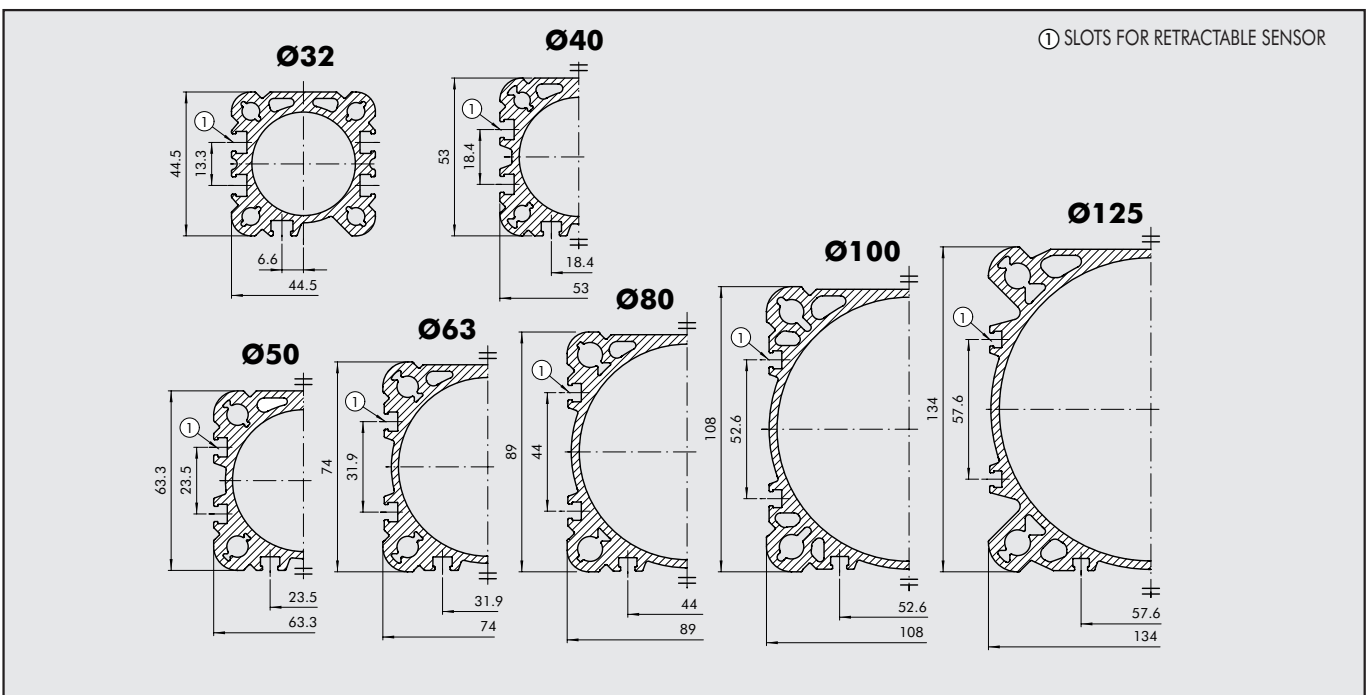



DIMENSIONS OF STANDARD VERSION

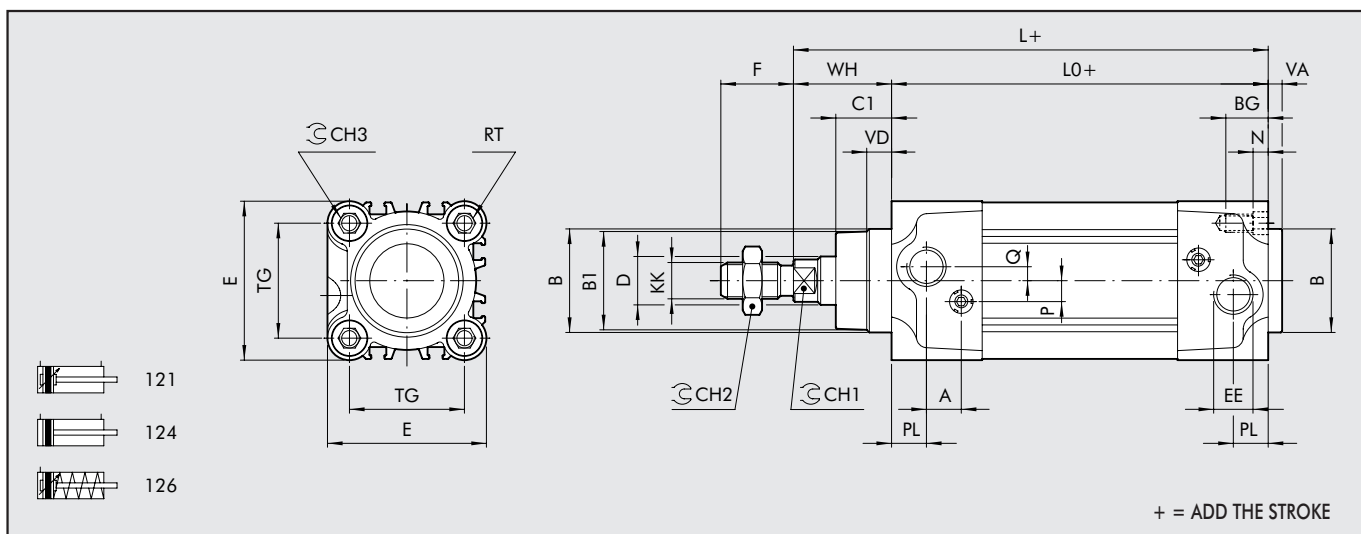

DIMENSIONS OF THROUGH-ROD VERSION

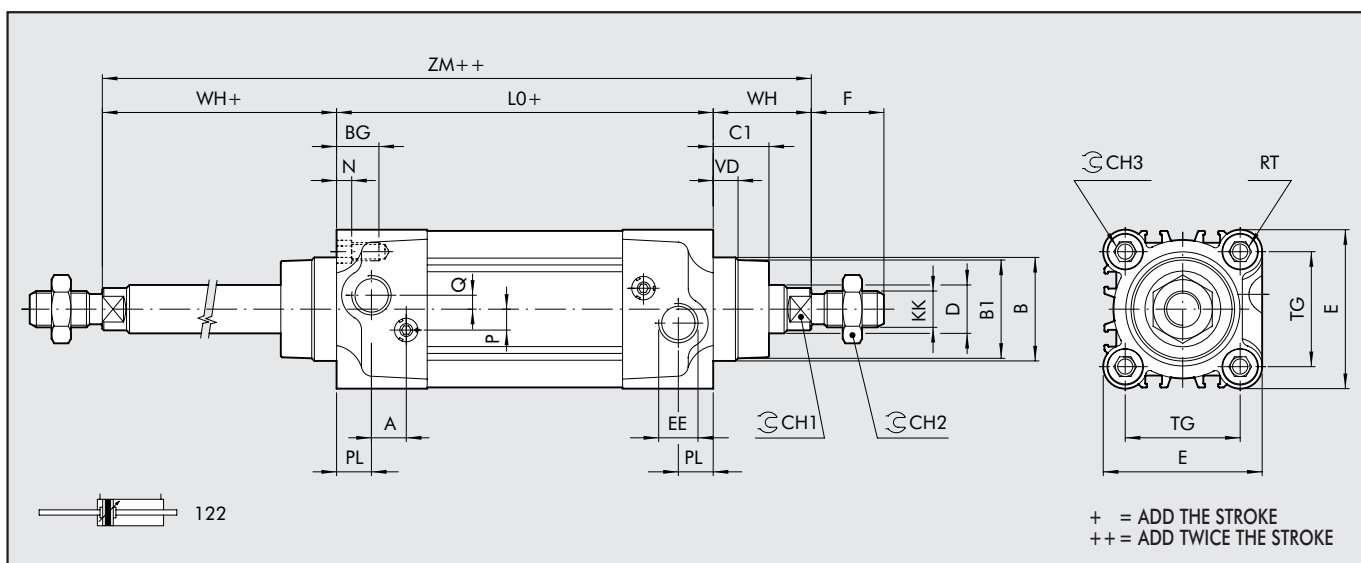

Ø.	PL	VD	A	B	B ₁	WH	C ₁	CH ₁	CH ₂	CH ₃	KK	D	TG	VA	F	EE	RT	E	L	L ₀	ZM	BG	N	P	Q
32	10	6.5	10	30	28	26	16	10	17	6	M10x1.25	12	32.5	4	22	G1/8	M6	46	120	94	146	14.5	4.5	6	4
40	12	8	10	35	33	30	20	13	19	6	M12x1.25	16	38	4	24	G1/4	M6	54	135	105	165	14.5	4.5	6	4
50	14	13	10	40	38	37	25	17	24	8	M16x1.5	20	46.5	4	32	G1/4	M8	64.5	143	106	180	17.5	5.5	6	6
63	16	14	10	45	40	37	25	17	24	8	M16x1.5	20	56.5	4	32	G3/8	M8	75.5	158	121	195	17.5	5.5	6	6
80	18	12	12	45	43	46	33	22	30	10	M20x1.5	25	72	4	40	G3/8	M10	94	174	128	220	21.5	5.5	10	7
100	20	14	12	55	49	51	38	22	30	10	M20x1.5	25	89	4	40	G1/2	M10	111	189	138	240	21.5	5.5	10	7
125	25	20	10	60	54	65	45	27	41	12	M27x2	32	110	6	54	G1/2	M12	135	225	160	290	25.5	6.5	12	8

VERSION 126 (SINGLE-ACTING)

	Upper limit	Stroke	Lower limit	L0 - Ø 32	L0 - Ø 40	L0 - Ø 50	L0 - Ø 63	L - Ø 32	L - Ø 40	L - Ø 50	L - Ø 63
ISO	0	< C ≤	25	94	105	106	121	120	135	143	158
ISO	25	< C ≤	50	94	105	106	121	120	135	143	158
NON ISO	50	< C ≤	75	115	129.5	130.5	145.5	141	159.5	167.5	182.5
NON ISO	75	< C ≤	100	136	154	155	170	162	184	192	207
NON ISO	100	< C ≤	125	157	178.5	179.5	194.5	183	208.5	216.5	231.5
NON ISO	125	< C ≤	150	178	203	204	219	204	233	241	256
NON ISO	150	< C ≤	175	199	227.5	228.5	243.5	225	257.5	265.5	280.5
NON ISO	175	< C ≤	200	220	252	253	268	246	282	290	305
NON ISO	200	< C ≤	225	241	276.5	277.5	292.5	267	306.5	314.5	329.5
NON ISO	225	< C ≤	250	262	301	302	317	288	331	339	354

DIMENSIONS OF 100 mm CUSHIONING VERSION

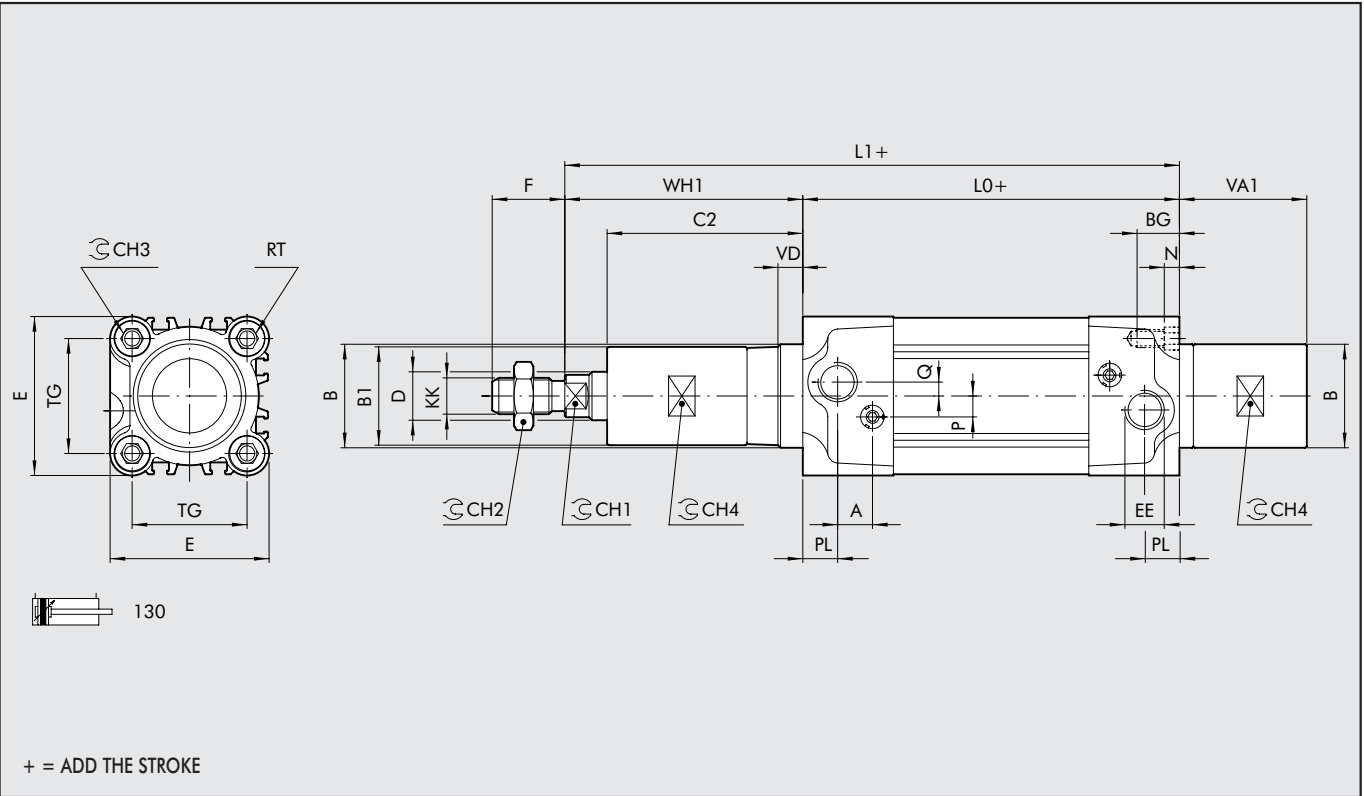

Ø	PL	VD	A	B	B ₁	WH ₁	C ₂	CH ₁	CH ₂	CH ₃	CH ₄	KK	D	TG	VA ₁	F	EE	RT	E	L ₁	L ₀	BG	N	P	Q
32	10	6.5	10	30	29	106	96	10	17	6	27	M10x1.25	12	32.5	79	22	G1/8	M6	46	200	94	14.5	4.5	6	4
40	12	8	10	35	34	107	97	13	19	6	30	M12x1.25	16	38	76.5	24	G1/4	M6	54	212	105	14.5	4.5	6	4
50	14	13	10	40	38	113.5	101.5	17	24	8	35	M16x1.5	20	46.5	76.5	32	G1/4	M8	64.5	219.5	106	17.5	5.5	6	6
63	16	14	10	45	38	113.5	101.5	17	24	8	35	M16x1.5	20	56.5	76.5	32	G3/8	M8	75.5	234.5	121	17.5	5.5	6	6

DIMENSIONS OF 150 mm CUSHIONING VERSION

Ø	WH ₁	C ₂	VA ₁	L ₁
32	156	146	129	250
40	157	147	121.5	262
50	162.5	150.5	119.5	268.5
63	162.5	150.5	123.5	283.5

DIMENSIONS OF 200 mm CUSHIONING VERSION

Ø	WH ₁	C ₂	VA ₁	L ₁
32	206	196	179	300
40	207	197	176.5	312
50	213.5	201.5	176.5	319.5
63	213.5	201.5	176.5	334.5



DIMENSIONS OF TANDEM VERSION

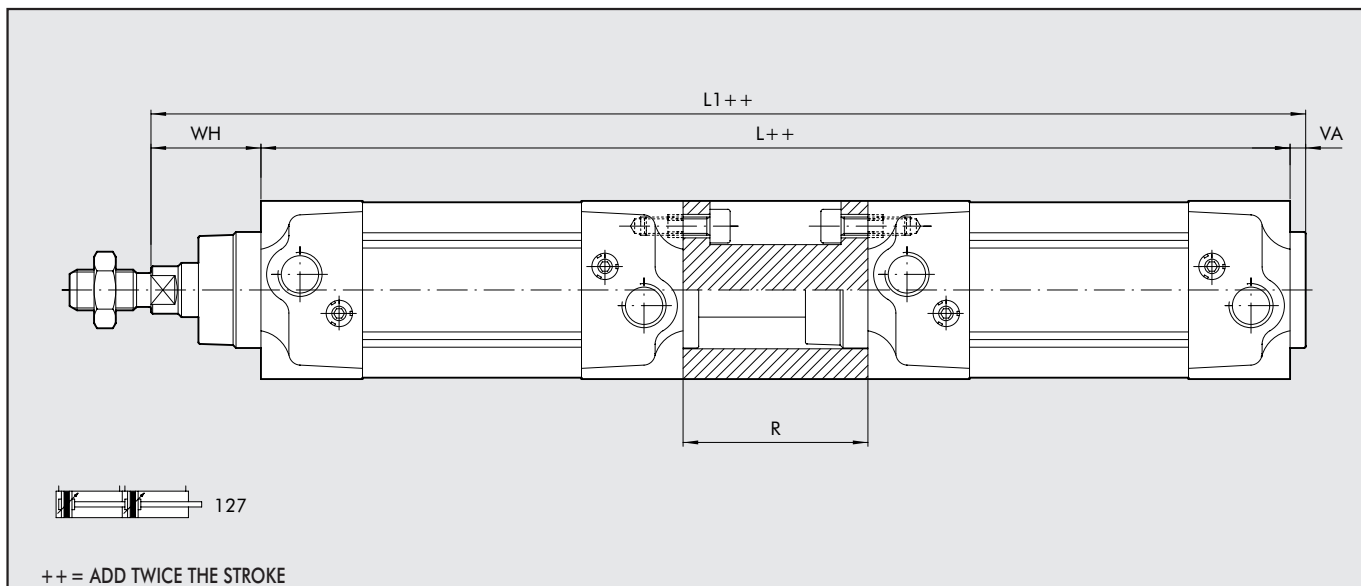

Ø	WH	VA	R	L	L ₁	
32	26	4	55	243	273	
40	30	4	55	265	299	
50	37	4	68	280	321	
63	37	4	68	310	351	
80	46	4	92	348	398	
100	51	4	92	368	423	
125	65	6	120	440	511	Refer to standard cylinders for other values.

DIMENSIONS OF OPPOSED VERSION

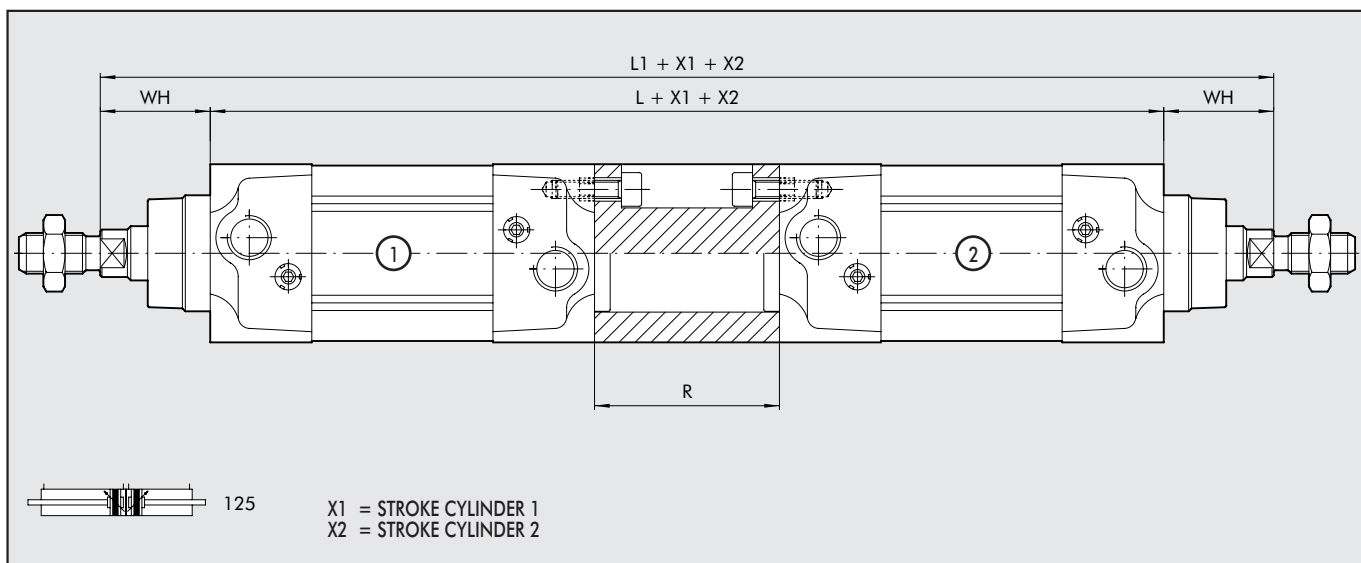

Ø	WH	R	L	L ₁	
32	26	55	243	295	
40	30	55	265	325	
50	37	68	280	354	
63	37	68	310	384	
80	46	92	348	440	
100	51	92	368	470	
125	65	120	440	570	Refer to standard cylinders for other values.

LOW-FRICTION VERSION – CODE 129

- ① Rear chamber piston gasket made of polyurethane (Ø 32-125);
- ② Front chamber piston gasket made of polyurethane (Ø 32-125);
- ③ Rear chamber cushioning gasket made of polyurethane;
- ④ Front chamber cushioning gasket made of polyurethane;
- ⑤ Piston rod gasket made of polyurethane.

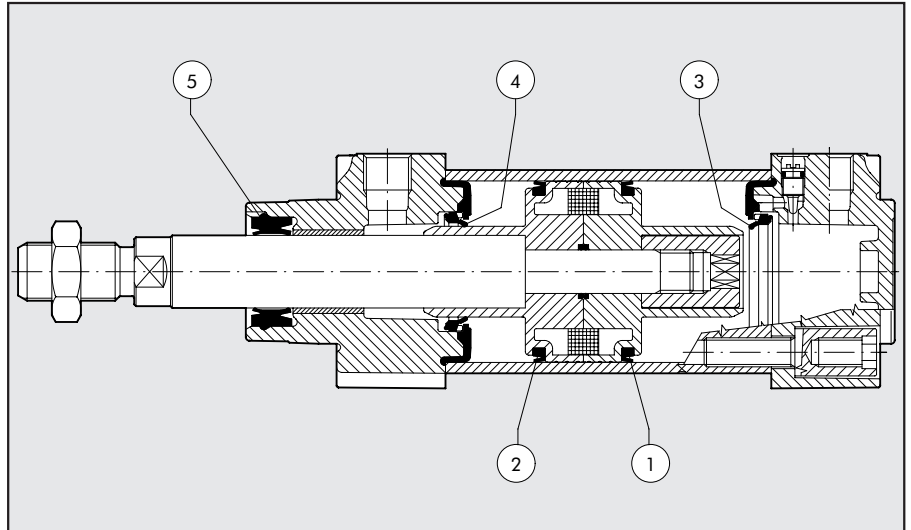

	Type	Gaskets
Rear chamber pressure	A	1
Rear chamber pressure and cushioning in case of impact	B	1+3
Rear chamber pressure and piston rod gasket	C	1+5
Rear chamber pressure, cushioning in case of impact and piston rod gasket	D	1+3+5
Front chamber pressure	E	2+5
Front chamber pressure and cushioning in case of impact	F	2+5+4

The low-friction cylinder is typically used as a dandy or tensoning cylinder since it is a single-acting cylinder without a return spring. The configurations are shown below:

- 1) The best type is A as it involves less friction.
- 2) Type B should be used when the cylinder is working under normal conditions outside the pneumatic cushioning area. Cushioning is only for emergency use. It acts as a shock absorber in the case of malfunction.
- 3) Type C differs from type A due to the presence of a piston rod gasket that prevents dirt getting in when operating in dirty environments.
- 4) Type D differs from type B due to the presence of a piston rod gasket that prevents dirt getting in when operating in dirty environments.
- 5) Type E should be used when the pressurized chamber is the front one.
- 6) For type F, see point 2.

NB. THE CYLINDER IS ALWAYS SINGLE-ACTING WITHOUT A RETURN SPRING.

NOTES



KEY TO CODES

CYLINDER ISO 15552 TYPE "A", RETRACTABLE SENSOR

CYL	1	2	1	A	3	2	0	0	5	0	C	P
	TYPE			DIAMETER			STROKE					
	121	Double-acting, cushioned		A Standard	32		For the maximum suppliable strokes, look at the technical data				A C45 chromed rod, aluminium piston rod: standard for all cylinders with ≥ 1000 mm-stroke cylinders and for cylinder with $\varnothing 80$ mm and over	N NBR gaskets
	122	Through-rod		▲ B No stick slip	40						C C45 chromed rod, technopolymer piston: standard for cylinders of $\varnothing 32$ to $\varnothing 63$ mm with < 1000 mm strokes	P polyurethane gaskets
	124	Double-acting, non-cushioned		C Non-magnetic	50						Z Stainless steel piston rod and nut aluminium piston	V FKM/FPM gaskets
	125	Opposed			63						X Stainless steel piston rod and nut technopolymer piston	• B low temperature
	◆ 126	Single-acting			80							
	127	Tandem			A1=100							
	134	Rod lock version			A2=125							
	136	Version with piston rod lock										
	◆ 137	Piston rod lock + guide unit										

- Only available for versions with aluminium piston (A or Z)
- ◆ Available until $\varnothing 63$ and only the versions with piston in aluminum (A or Z)
- ▲ Not available for NBR (N) versions
- ◆ Available up to $\varnothing 100$

CYLINDER ISO 15552 LOW-FRICTION TYPE "A", RETRACTABLE SENSOR

CYL	1	2	9	A	3	2	0	0	5	0	C	P
	TYPE			DIAMETER			STROKE					
	A	Low friction, type A		32		$\varnothing 32 \div \varnothing 80$	A C45 chromed rod, aluminium piston rod: standard for all cylinders with ≥ 1000 mm-stroke cylinders and for cylinder with $\varnothing 80$ mm and over				N NBR gaskets	
	B	Low friction, type B		40		stroke 25÷2800 mm	C C45 chromed rod, technopolymer piston: standard for cylinders of $\varnothing 32$ to $\varnothing 63$ mm with < 1000 mm strokes				P Polyurethane gaskets	
	C	Low friction, type C		50		$\varnothing 100 \div \varnothing 125$	Z Stainless steel piston rod and nut aluminium piston				V FKM/FPM gaskets	
	D	Low friction, type D		63		stroke 25÷2600 mm	X Stainless steel piston rod and nut technopolymer piston					
	E	Low friction, type E		80								
	F	Low friction, type F		A1= $\varnothing 100$ A2= $\varnothing 125$								

CYLINDER ISO 15552 LONG-CUSHIONING TYPE "A", RETRACTABLE SENSOR

CYL	1	3	0	A	3	2	0	0	5	0	C	P
	TYPE			DIAMETER			STROKE					
	A	200 mm front/rear cushioning cone – 200mm ext.		32		25÷2600 mm	A C45 chromed rod, aluminium piston rod for all sizes				N NBR gaskets	
	B	150 mm front/rear cushioning cone – 150mm ext.		40			Z Stainless steel piston rod and nut aluminium piston				P polyurethane gaskets	
	C	100 mm front/rear cushioning cone – 100mm ext.		50							V FKM/FPM gaskets	
	D	150 mm front/rear cushioning cone – 200mm ext.		63								
	E	100 mm front/rear cushioning cone – 200mm ext.										
	F	50 mm front/rear cushioning cone – 100mm ext.										
	G	100 mm front/rear cushioning cone – 150mm ext.										
	H	200 mm front cushioning cone – 200 mm ext.										
	I	150 mm front cushioning cone – 150 mm ext.										
	L	100 mm front cushioning cone – 100 mm ext.										
	M	150 mm front cushioning cone – 200 mm ext.										
	N	100 mm front cushioning cone – 150 mm ext.										
	O	50 mm front cushioning cone – 100 mm ext.										
	Q	200 mm rear cushioning cone – 200 mm ext.										
	R	150 mm rear cushioning cone – 150 mm ext.										
	S	100 mm rear cushioning cone – 100 mm ext.										
	T	150 mm rear cushioning cone – 200 mm ext.										
	U	100 mm rear cushioning cone – 200 mm ext.										
	V	50 mm rear cushioning cone – 100 mm ext.										

ACCESSORIES: FIXINGS

INTERMEDIATE HINGE - MODEL EN

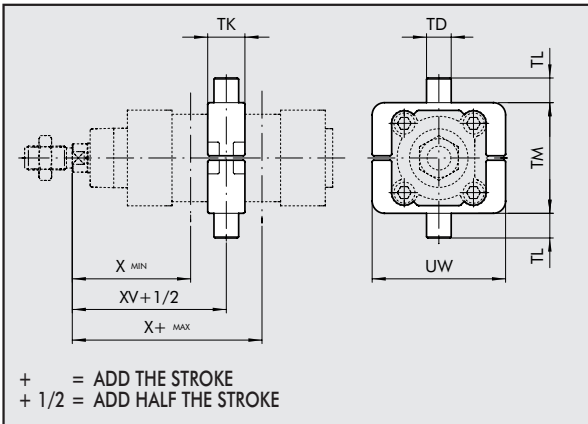

Code	Ø	X _(min)	XV	X _(max)	TM	TL	TD _{e9}	TK	UW	Weight [g]
0950322107	32	63	73	83	50	12	12	22	65	170
0950402107	40	72	82.5	93	63	16	16	28	75	360
0950502107	50	83	90	97	75	16	16	28	95	580
0950632107	63	86.5	97.5	108.5	90	20	20	36	105	950
0950802107	80	104	110	116	110	20	20	36	130	1480
0951002107	100	113.5	120	126.5	132	25	25	45	145	2140
0951252107	125	135	145	155	160	25	25	50	175	2950

Note: Supplied complete with 4 grub screws, 2 pins

COUNTER-HINGE FOR MODEL EN - MODEL EL

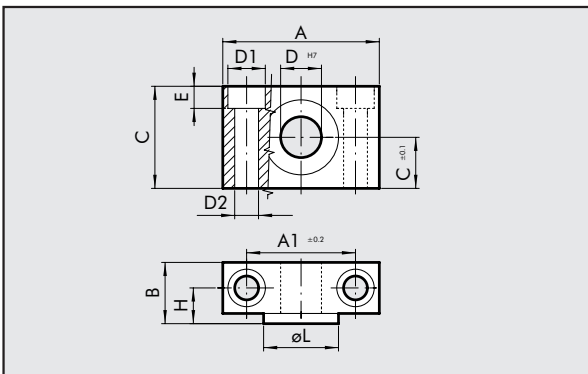

Code	Ø	A	A ₁	B	C	C ₁	D ₁	D ₂	D	E	H	ØL	Weight [g]
W0950322009	32	46	32	18	30	15	11	7	12	6.5	10.5	22	162
W0950402009	40	55	36	21	36	18	15	9	16	8.5	12	28	278
W0950502009	50	55	36	21	36	18	15	9	16	8.5	12	28	278
W0950632009	63	65	42	23	40	20	18	11	20	10.5	13	35	414
W0950632009	80	65	42	23	40	20	18	11	20	10.5	13	35	414
W0951002009	100	75	50	28.5	50	25	20	13	25	12.5	16	40	715
W0951002009	125	75	50	28.5	50	25	20	13	25	12.5	16	40	715

Note: Supplied with 4 securing screws

VALVE ASSEMBLY ON CYLINDER

With this type of cylinder, the valves (D) can be mounted directly using the retracting sensor slot, without requiring the use of intermediate brackets.

This can be done using the special plates (A), which come with both the M3 and M4 threads, and screws (B) of the size, type and quantity shown in the table below.

For ISO 1 and ISO 2 valves, the kit on which the valve is to be mounted (codes shown in the tables) will be fitted to the cylinder using the special plates (A) and the screws (B) listed in the table.

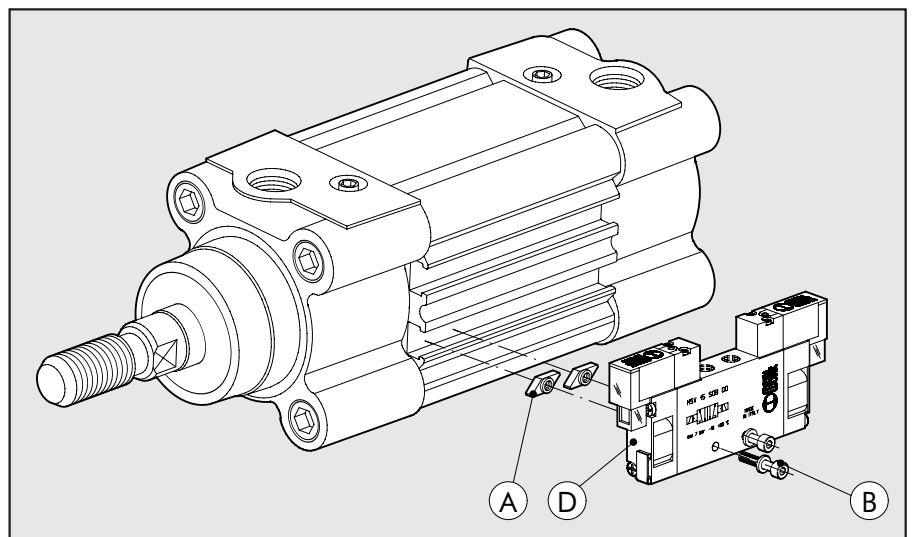

Type of valve to mount (D)	M3 fixing plate (A) code 0950003002	M4 fixing plate (A) code 0950003001	Screw (B) for connection to cylinder (one per plate)	Washer (B) (one per screw)	Valve assembly kit
MACH 11	n° 2	-	M3x16 UNI 5931 (DIN 912)	A3.2 UNI 1751 (DIN 127A)	-
SERIE 70 1/8	-	n° 2	M4x25 UNI 5931 (DIN 912)	-	-
SERIE 70 1/4	-	n° 2	M4x30 UNI 5931 (DIN 912)	A4.3 UNI 1751 (DIN 127A)	-
SERIE 70 1/2	-	n° 2	M4x45 UNI 5931 (DIN 912)	A4.3 UNI 1751 (DIN 127A)	-
ISO 1	-	n° 2	M4x8 UNI 7688 (DIN 965A)	-	0950002001
ISO 2	-	n° 2	M4x8 UNI 7688 (DIN 965A)	-	0950002002



ACCESSORIES: MAGNETIC SENSORS

1

RETRACTABLE SENSOR WITH INSERTION FROM ABOVE

Code Description

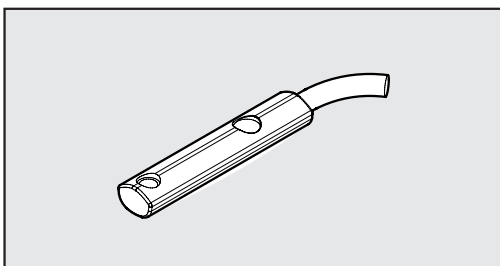

W0952025390	HALL N.O. SENSOR, VERTICAL INSERTION 2.5m
W0952029394	HALL N.O. SENSOR, VERTICAL INSERTION 300 mm M8
W0952022180	REED N.O. SENSOR, VERTICAL INSERTION 2.5m
W0952028184	REED N.O. SENSOR, VERTICAL INSERTION 300 mm M8
W0952125556	HALL N.O. SENSOR VETICAL INSERTION 2m ATEX

This type of sensor can be inserted in the slot of the sensor from above. This means the cylinder heads do not require a through opening.

WIRING DIAGRAM

TECHNICAL DATA

ATEX

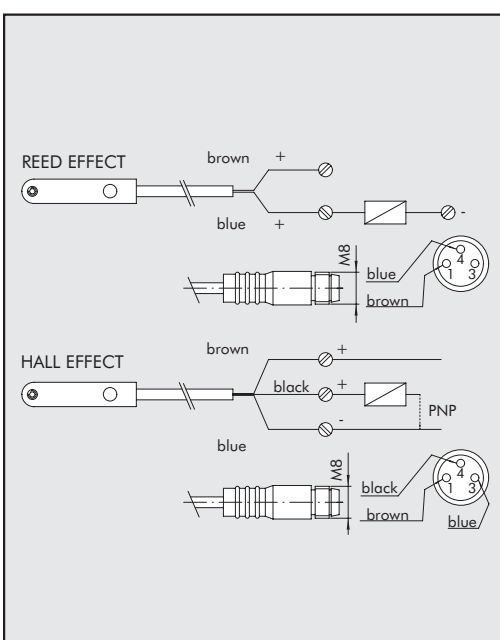

	Reed	Effetto Hall	Effetto Hall
Type of contact	N.O.	N.O.	N.O.
Switch	-	PNP	PNP
Supply voltage (U _b)	V 10 ÷ 30 AC/DC	10 ÷ 30 DC	18 ÷ 30 DC
Power	W 3 (peak valve=6)	3	≤ 1.7
Voltage variation	-	≤ 10% di U _b	≤ 10% di U _b
Voltage drop	V -	≤ 2	≤ 2.2
Input current	mA -	≤ 10	≤ 10
Output current	mA ≤ 100	≤ 100	≤ 70
Switching frequency	Hz ≤ 400	≤ 5000	1000
Short-circuit protection	-	Yes	Yes
Over-voltage suppression	-	Yes	Yes
Polarity inversion protection	-	Yes	Yes
EMC	EN 60 947-5-2	EN 60 947-5-2	EN 60 947-5-2
LED display	Yellow	Yellow	Yellow
Magnetic sensitivity	2,8 mT ±25%	2,8 mT ±25%	2.6
Repeatability	≤ 0,1 mT	≤ 0,1 mT	≤ 0,1 (U _b and ta fixed)
Degree of protection (EN 60529)	IP 67	IP 67	IP 68, IP 69K
Vibration and shock resistance	30 g, 11 ms, 10÷55 Hz, 1mm	30 g, 11 ms, 10÷55 Hz, 1mm	30 g, 11 ms, 10÷55 Hz, 1mm
Temperature range	°C -25 ÷ +75	-25 ÷ +75	-20 ÷ +45
Sensor capsule material	PA66 + PA6I/6T	PA66 + PA6I/6T	PA
2.5m/2m connecting cable	PVC; 2 x 0,12 mm ²	PVC; 3 x 0,14 mm ²	PVC; 3 x 0,12 mm ²
Connecting cable with M8x1	Polyurethane; 2 x 0,14 mm ²	Polyurethane; 3 x 0,14 mm ²	-
Wire NO.	2	3	3

BAR FOR GROOVING

Code Description

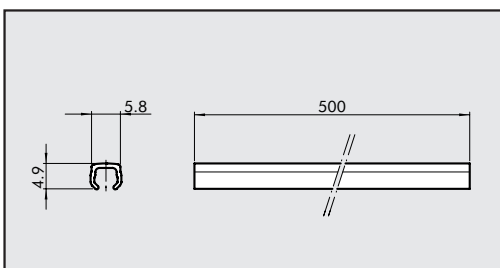

W0950000160 BAR FOR GROOVING L=500 mm

Note: The code corresponds to 1 piece.

SLOTTED FIXING PLATE

Code Description Weight [g]

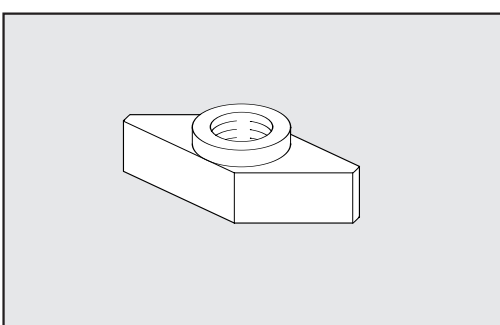

0950003001	ACC M4 T-SLOTTED FIXING PLATE	1
0950003002	ACC M3 T-SLOTTED FIXING PLATE	1

Note: Individually packed

ACCESSORIES ISO 15552 STD AND TYPE "A" RETRACTABLE SENSOR: MECHANICAL ROD BLOCK

Pilot pressure	Pp	4-8 bar (0.4-0.8 Mpa)														
Ambient temperature	Te	Max 80°C (176°F)														
Fluid temperature	tg	Max 70°C (154°F)														
Operation		NC - bidirectional														
Mechanics		Double shoe with mechanical lock														
Locking force	F	<table border="1"> <tr> <td>Ø32</td> <td>Ø40</td> <td>Ø50</td> <td>Ø63</td> <td>Ø80</td> <td>Ø100</td> <td>Ø125</td> </tr> <tr> <td>650</td> <td>1100</td> <td>1600</td> <td>2500</td> <td>4000</td> <td>6300</td> <td>8700</td> </tr> </table>	Ø32	Ø40	Ø50	Ø63	Ø80	Ø100	Ø125	650	1100	1600	2500	4000	6300	8700
Ø32	Ø40	Ø50	Ø63	Ø80	Ø100	Ø125										
650	1100	1600	2500	4000	6300	8700										
Body material	(N)	Aluminium														
Shoe material		Brass														
Spring material		NBR														
Piston material		Synthetic material with added teflon														
Gasket material		NBR														
Pilot port		1/8"														

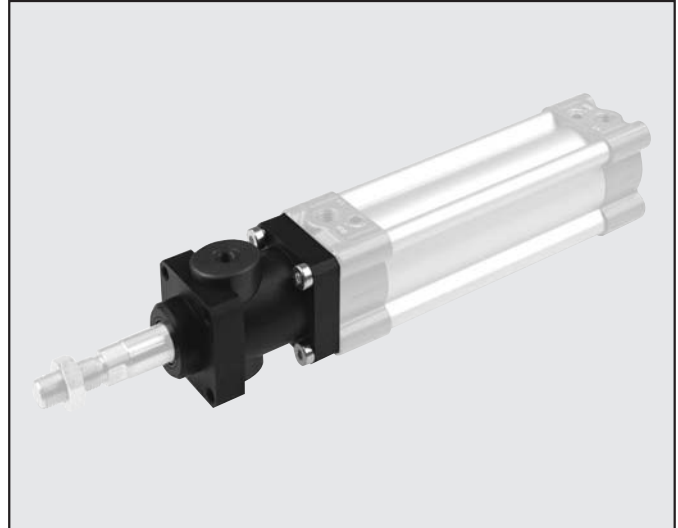

OPERATING PRINCIPLE

The mechanical piston rod lock is a normally-closed mechanism. In the absence of pneumatic piloting, the two shoes (A) lock the cylinder rod in both directions (Fig. 1). With pneumatic piloting, the piston rod guide forces the shoes to come right up to each other and overcome the counter spring (B) force and the piston rod can slide (Fig. 2). It is important to remember that the mechanical piston rod lock is a static type, which means that it is necessary to stop the cylinder piston rod pneumatically before locking the part mechanically.

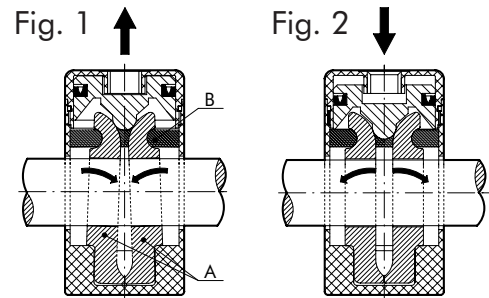

DIMENSIONS

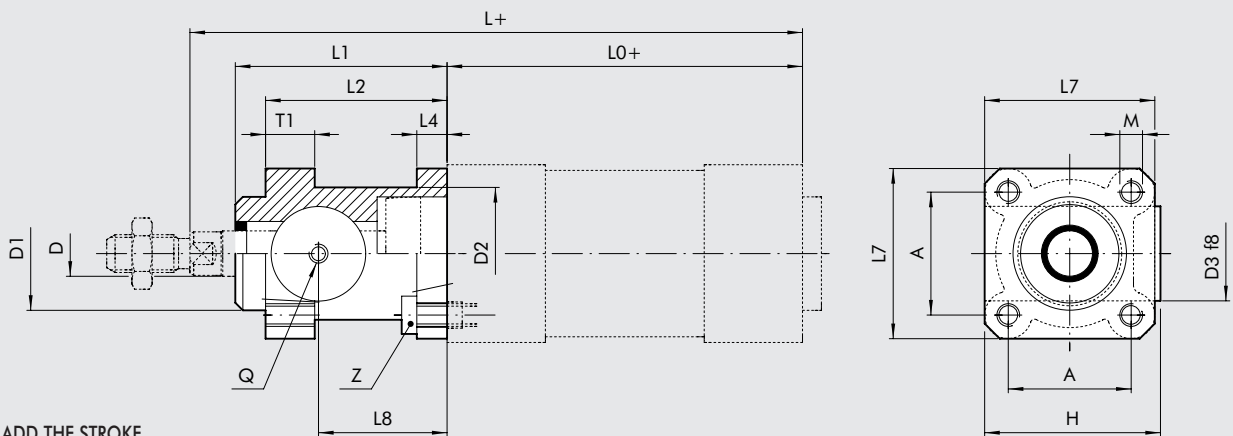

Code	Ø	L ₁	L ₂	L ₄	L ₇	L ₈	D	D ₁	D ₂	D ₃	H	A	T ₁	M	Z	Q	L ₀	L	Weight [g]
W5010001102	32	58	48	8	45	34	12	30	35	25	46.5	32.5	13	M6	M6x20	M5	94	162	150
W5010001103	40	65	55	8	50	38	16	35	40	28	53	38	13	M6	M6x20	G1/8	105	180	200
W5010001104	50	82	70	15	60	48	20	40	50	35	64	46.5	16	M8	M8x30	G1/8	106	200	500
W5010001109	63	82	70	15	70	49.5	20	45	60	38	75	56.5	16	M8	M8x30	G1/8	121	215	700
W5010001106	80	110	90	18	90	61	25	45	80	48	95	72	20	M10	M10x35	G1/8	128	251	1700
W5010001107	100	115	100	18	105	68	25	55	100	58	110.5	89	20	M10	M10x35	G1/8	138	266	2700
W5010001108	125	167	122	22	140	86.5	32	60	130	65	150	110	30	M12	M12x40	G1/8	160	347	5600



ACCESSORIES ISO 1552 STD AND TYPE "A" RETRACTABLE SENSOR: FIXINGS

1

FOOT - MODEL A

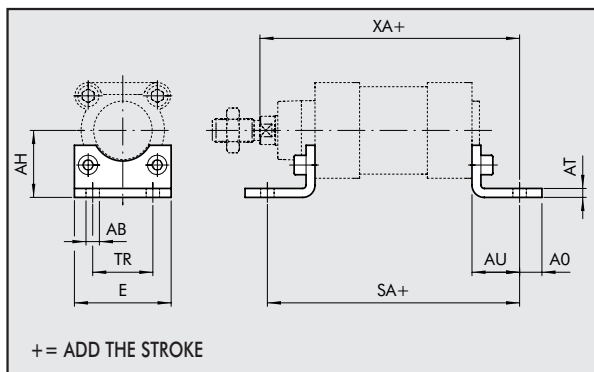

Code	Ø	Ø AB	AH	AO	AT	AU	TR	E	XA	SA	Weight [g]
W0950322001	32	7	32	11	4	24	32	45	144	142	76
W0950402001	40	9	36	15	4	28	36	52	163	161	100
W0950502001	50	9	45	15	4	32	45	65	175	170	162
W0950632001	63	9	50	15	6	32	50	75	190	185	266
W0950802001	80	12	63	20	6	41	63	95	215	210	456
W0951002001	100	14	71	25	6	41	75	115	230	220	572
W0951252001	125	16	90	15	7	45	90	140	270	250	1130

Note: individually packed with 2 screws.

FEMALE HINGE - MODEL B

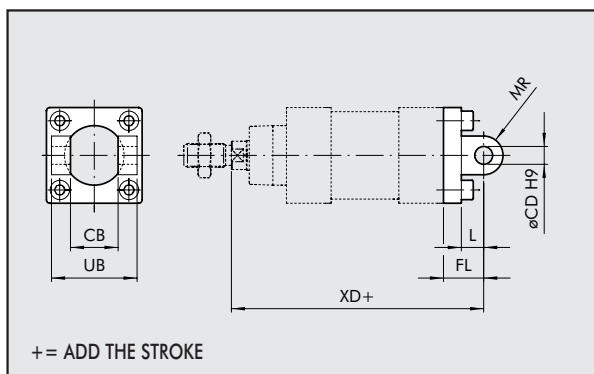

Code	Ø	UB	CB	FL	ØCD	XD	MR	L	Weight [g]
W0950322003	32	45	26	22	10	142	10	10	116
W0950402003	40	52	28	25	12	160	12	10	160
W0950502003	50	60	32	27	12	170	12	12	252
W0950632003	63	70	40	32	16	190	16	12	394
W0950802003	80	90	50	36	16	210	16	16	670
W0951002003	100	110	60	41	20	230	20	16	1085
W0951252003	125	130	70	50	25	275	25	20	2000

Note: Supplied with 4 screws, 4 washers, 2 snap-rings, 1 pin.

MALE HINGE - MODEL BA

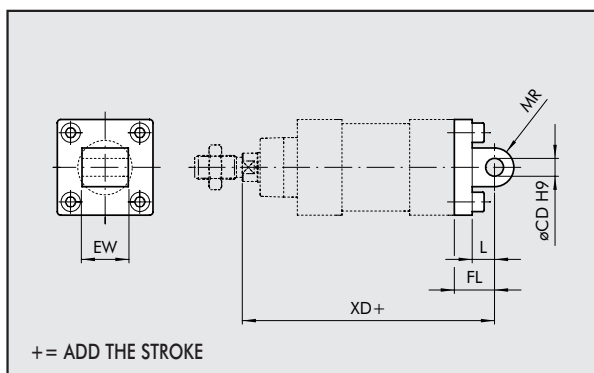

Code	Ø	EW	FL	MR	Ø CD	L	XD	Weight [g]
W0950322004	32	26	22	11	10	12	142	94
W0950402004	40	28	25	13	12	15	160	124
W0950502004	50	32	27	13	12	15	170	220
W0950632004	63	40	32	17	16	20	190	316
W0950802004	80	50	36	17	16	20	210	578
W0951002004	100	60	41	21	20	25	230	850
W0951252004	125	70	50	26	25	30	275	1590

Note: Supplied with 4 screws, 4 washers

ARTICULATED MALE HINGE - MODEL BAS

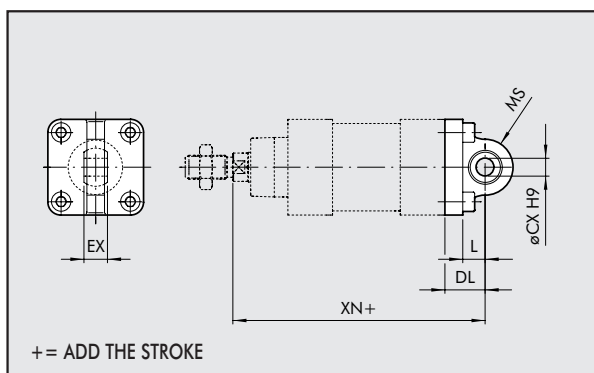

Code	Ø cil.	DL	MS	L	XN	CX	EX	Weight [g]
W0950322006	32	22	16	12	142	10	14	106
W0950402006	40	25	19	15	160	12	16	142
W0950502006	50	27	19	15	170	12	16	236
W0950632006	63	32	24	20	190	16	21	336
W0950802006	80	36	24	20	210	16	21	572
W0951002006	100	41	30	25	230	20	25	840
W0951252006	125	50	36	30	275	25	31	1520

Note: Supplied with 4 screws, 4 washers

CETOP HINGE FOR MODEL B - MODEL GL

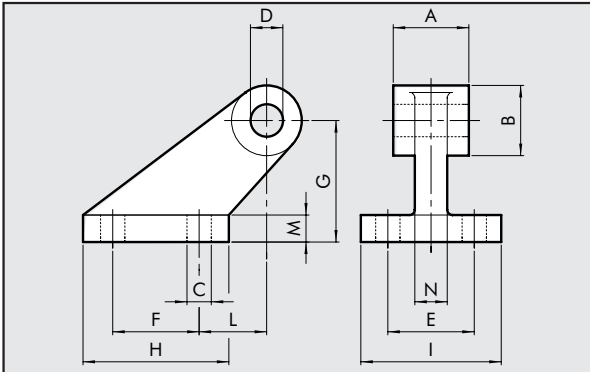

Code	Ø	A	B	C	D	E	F	G	H	I	L	M	N	Weight [g]
W0950322008	32	26	19	7	10	25	20	32	37	41	18	8	10	96
W0950402008	40	28	26	9	12	32	32	45	54	52	25	10	12	216
W0950502008	50	32	26	9	12	32	32	45	54	52	25	10	12	212
W0950632008	63	40	33	11	16	40	50	63	75	63	32	12	15	440
W0950802008	80	50	33	11	16	40	50	63	75	63	32	12	15	464
W0951002008	100	60	44	14	20	50	70	90	103	80	40	16	22	985
W0951252008	125	70	44	14	25	50	70	90	103	80	40	16	22	1000

Note: Supplied with 4 screws, 4 washers

ISO HINGE FOR MODEL B - MODEL GS

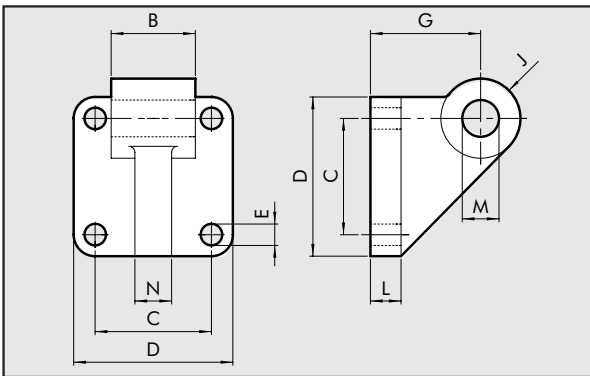

Code	Ø	B	C	D	E	G	J	L	M	N	Weight [g]
W0950322108	32	25.5	32.5	45	7	32	11	10	10	10	106
W0950402108	40	27.5	38	52	7	36	13	10	12	12	138
W0950502108	50	31.5	46.5	65	9	45	13	12	12	12	252
W0950632108	63	39.5	56.5	75	9	50	17	12	16	15	350
W0950802108	80	49.5	72	95	11	63	17	16	16	15	655
W0951002108	100	59.5	89	115	11	73	21	16	20	22	980

Note: Supplied with 4 screws, 4 washers

FRONT FLANGE - MODEL C

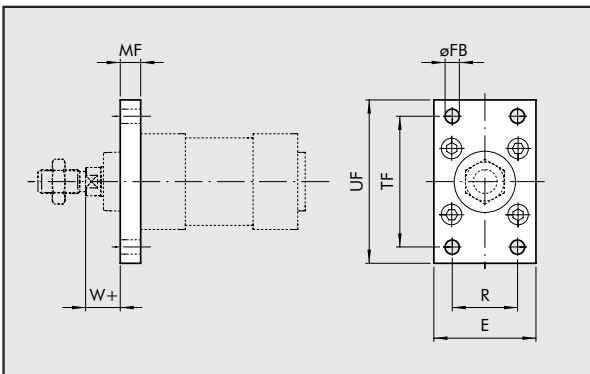

Code	Ø	TF	UF	E	MF	R	øFB	W	Weight [g]
W0950322002	32	64	80	50	10	32	7	16	246
W0950402002	40	72	90	55	10	36	9	20	290
W0950502002	50	90	110	65	12	45	9	25	522
W0950632002	63	100	120	75	12	50	9	25	670
W0950802002	80	126	153	95	16	63	12	30	1420
W0951002002	100	150	178	115	16	75	14	35	2040
W0951252002	125	180	220	140	20	90	16	45	4300

Note: Supplied with 4 screws.

REAR FLANGE - MODEL C

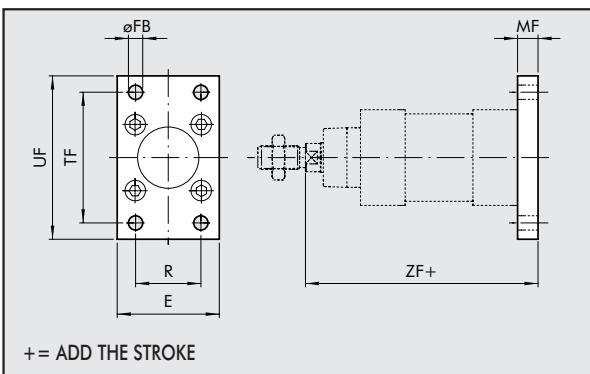

Code	Ø	TF	UF	E	MF	R	øFB	ZF	Weight [g]
W0950322002	32	64	80	50	10	32	7	130	246
W0950402002	40	72	90	55	10	36	9	145	290
W0950502002	50	90	110	65	12	45	9	155	522
W0950632002	63	100	120	75	12	50	9	170	670
W0950802002	80	126	153	95	16	63	12	190	1420
W0951002002	100	150	178	115	16	75	14	205	2040
W0951252002	125	180	220	140	20	90	16	245	4300

Note: Supplied with 4 screws.

+ = ADD THE STROKE



ROD NUT - MODEL S

Code Ø F H CH Weight [g]

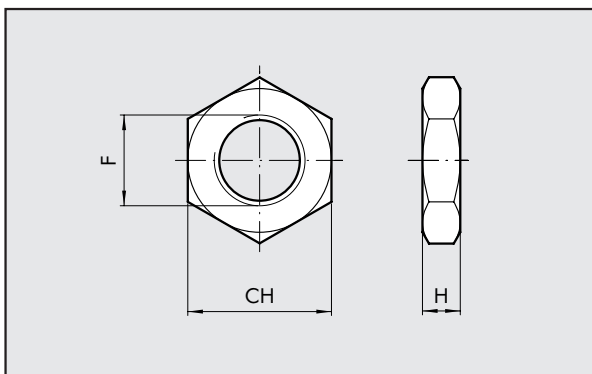

0950322010	32	M10x1.25	6	17	6
0950402010	40	M12x1.25	7	19	12
0950502010	50/63	M16x1.5	8	24	20
0950802010	80/100	M20x1.5	9	30	32
0951252010	125	M27x2	12	41	74

Note: Individually packed.

FORK MODEL GK-M

Code Ø Ø M C B A L F D N Weight [g]

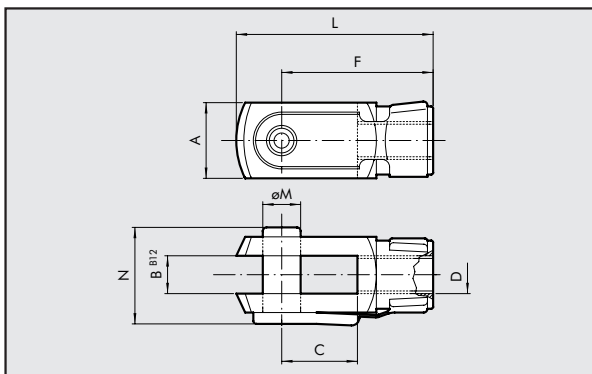

W0950322020	32	10	20	10	20	52	40	M10x1.25	26	92
W0950402020	40	12	24	12	24	62	48	M12x1.25	32	148
W0950502020	50	16	32	16	32	83	64	M16x1.5	40	340
W0950502020	63	16	32	16	32	83	64	M16x1.5	40	340
W0950802020	80	20	40	20	40	105	80	M20x1.5	40	690
W0950802020	100	20	40	20	40	105	80	M20x1.5	48	690
W0951252020	125	30	54	30	55	148	110	M27x2	65	1835

Note: Individually packed.

ROD EYE - MODEL GA-M

Code Ø Ø M C B1 B A L F D Ø G CH Ø G1 Weight [g]

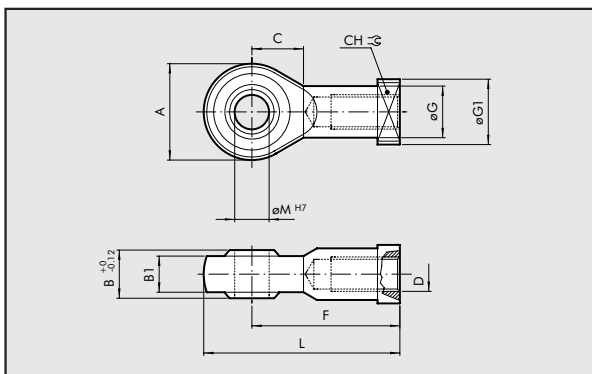

W0950322025	32	10	15	10.5	14	28	57	43	M10x1.25	15	17	19	78
W0950402025	40	12	17	12	16	32	66	50	M12x1.25	17.5	19	19	116
W0950502025	50	16	22	15	21	42	85	64	M16x1.5	22	22	22	226
W0950502025	63	16	22	15	21	42	85	64	M16x1.5	22	22	22	226
W0950802025	80	20	26	18	25	50	102	77	M20x1.5	27.5	30	27	404
W0950802025	100	20	26	18	25	50	102	77	M20x1.5	27.5	30	27	404
W0951252025	125	30	36	25	37	70	145	110	M27x2	40	41	50	1190

Note: Individually packed

SELF ALIGNING ROD COUPLER - MODEL GA-K

Code Ø A B C D ØF ØE SW₁ SW₂ SW₃ SW₄ SW₅ Weight [g]

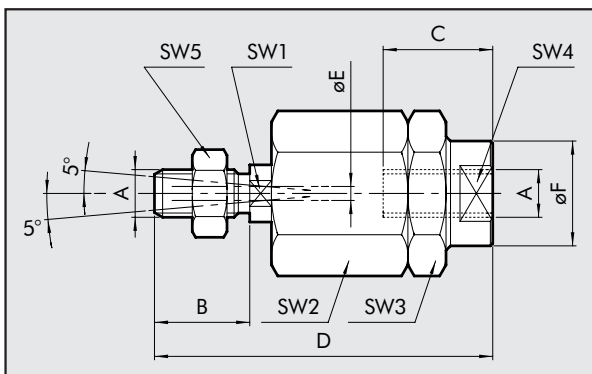

W0950322030	32	M10x1.25	20	20	71	22	4	12	30	30	19	17	216
W0950402030	40	M12x1.25	24	20	75	22	4	12	30	30	19	19	220
W0950502030	50	M16x1.5	32	32	103	32	4	20	41	41	30	24	620
W0950502030	63	M16x1.5	32	32	103	32	4	20	41	41	30	24	620
W0950802030	80	M20x1.5	40	40	119	32	4	20	41	41	30	30	680
W0950802030	100	M20x1.5	40	40	119	32	4	20	41	41	30	30	680

Note: Individually packed

CYLINDERS ISO 15552 STD AND TYPE "A" RETRACTABLE SENSOR: SPARES

NEW RELEASE

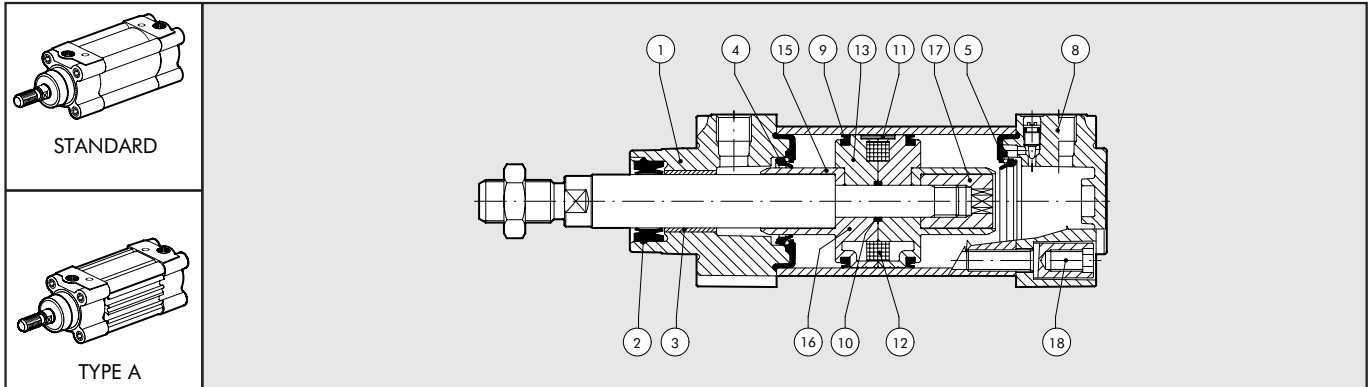

Type	Parts	Bore	Code
Complete set of polyurethane gaskets	2-4-5-9-10	Ø 32÷125	009 ... 0101
Complete set of NBR gaskets	2-4-5-9-10	Ø 32÷125	009 ... 0502
Complete polyurethane front head kit	1-2-3-4-5-17-18	Ø 32÷125	009 ... 0110N
Complete NBR front head kit	1-2-3-4-5-17-18	Ø 32÷125	009 ... 0304N
Complete polyurethane rear head kit	4-5-8-17-18	Ø 32÷125	009 ... 0111N
Complete NBR rear head kit	4-5-8-17-18	Ø 32÷125	009 ... 0305N
Complete polyurethane piston kit	9-10-16-17	Ø 32÷63	009 ... 0604
Complete polyurethane piston kit	9-10-11-13-15-18	Ø 80÷125	009 ... 0604
Complete NBR piston kit	9-10-16-17	Ø 32÷63	009 ... 0602
Complete NBR piston kit	9-10-11-13-15-18	Ø 80÷125	009 ... 0602
Complete polyurethane head A+P+piston kit	1-2-3-4-5-8-9-10-16-17-18	Ø 32÷63	009 ... 0704N
Complete polyurethane head A+P+piston kit	1-2-3-4-5-8-9-10-11-13-15-17-18	Ø 80÷125	009 ... 0704N
Complete NBR head A+P+piston kit	1-2-3-4-5-8-9-10-14-16-17-18	Ø 32÷63	009 ... 0702N
Complete NBR head A+P+piston kit	1-2-3-4-5-8-9-10-11-13-15-17-18	Ø 80÷125	009 ... 0702N
Magnet	12	Ø 32÷125	009 ... 0800

OLD RELEASE

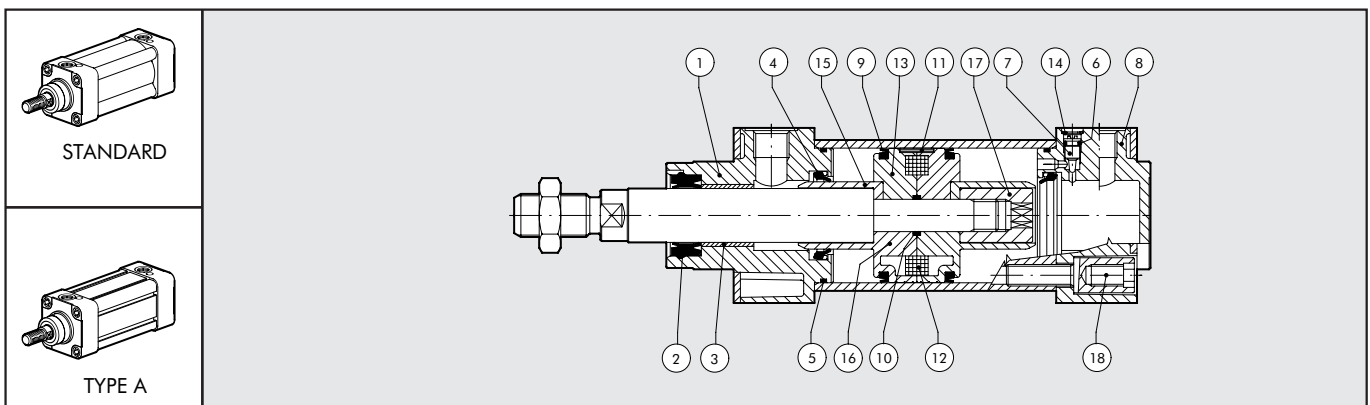

Type	Parts	Bore	Code
Complete set of polyurethane gaskets	2-4-5-9-10	Ø 32÷125	009 ... 0101
Complete set of NBR gaskets	2-4-5-9-10	Ø 32÷125	009 ... 0502
Complete polyurethane front head kit	1-2-3-4-5-6-7-14-17-18	Ø 32÷125	009 ... 0110
Complete NBR front head kit	1-2-3-4-5-6-7-14-17-18	Ø 32÷125	009 ... 0304
Complete polyurethane rear head kit	4-5-6-7-8-14-17-18	Ø 32÷125	009 ... 0111
Complete NBR rear head kit	4-5-6-7-8-14-17-18	Ø 32÷125	009 ... 0305
Complete polyurethane piston kit	9-10-16-17	Ø 32÷63	009 ... 0604
Complete polyurethane piston kit	9-10-11-13-15-18	Ø 80÷125	009 ... 0604
Complete NBR piston kit	9-10-16-17	Ø 32÷63	009 ... 0602
Complete NBR piston kit	9-10-11-13-15-18	Ø 80÷125	009 ... 0602
Complete polyurethane head A+P+piston kit	1-2-3-4-5-6-7-8-9-10-14-16-17-18	Ø 32÷63	009 ... 0704
Complete polyurethane head A+P+piston kit	1-2-3-4-5-6-7-8-9-10-11-13-14-15-17-18	Ø 80÷125	009 ... 0704
Complete NBR head A+P+piston kit	1-2-3-4-5-6-7-8-9-10-14-16-17-18	Ø 32÷63	009 ... 0702
Complete NBR head A+P+piston kit	1-2-3-4-5-6-7-8-9-10-11-13-14-15-17-18	Ø 80÷125	009 ... 0702
Magnet	12	Ø 32÷125	009 ... 0800

GRAPH OF GUIDE UNIT LOADS

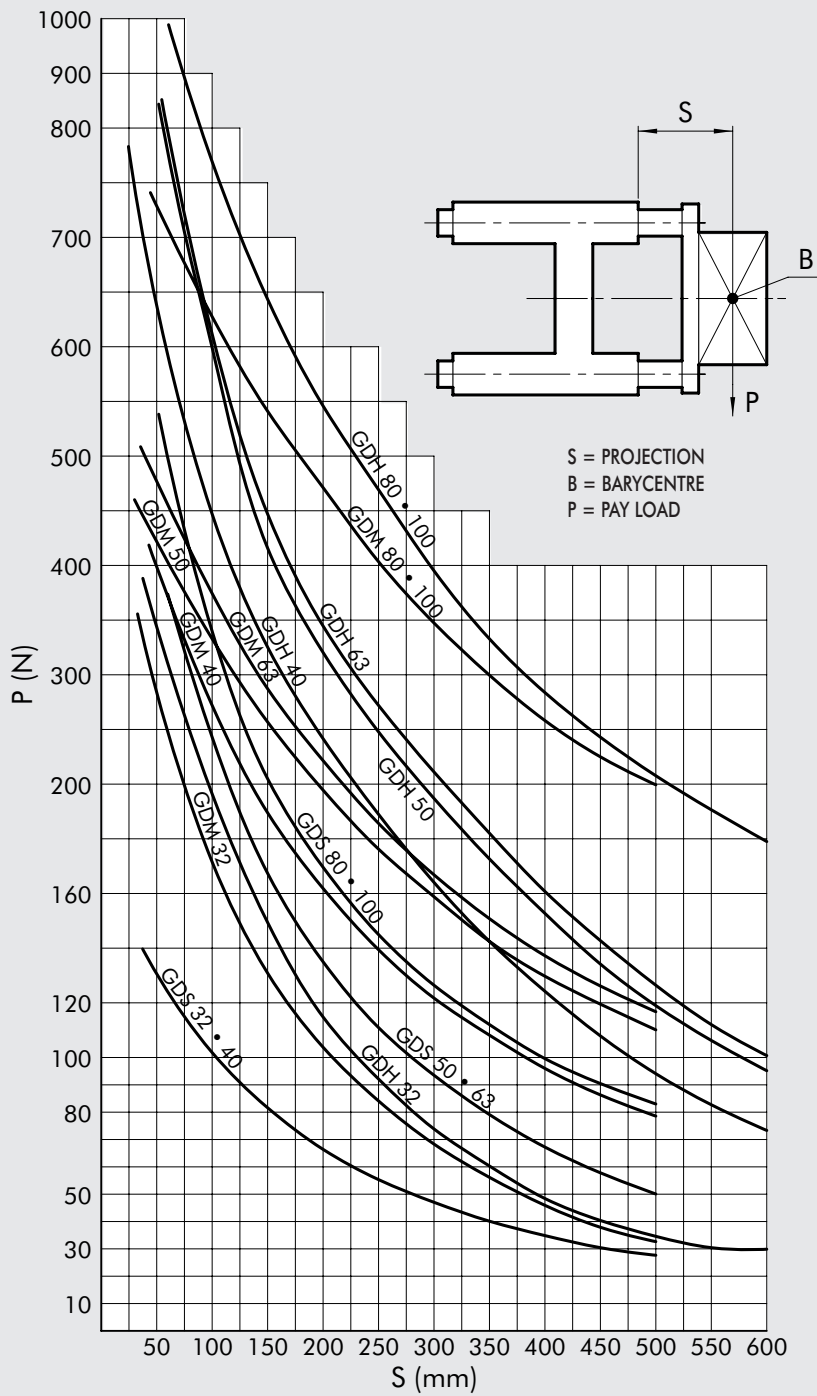

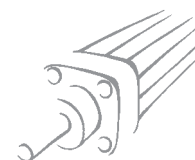

DIMENSIONS TYPE GDS

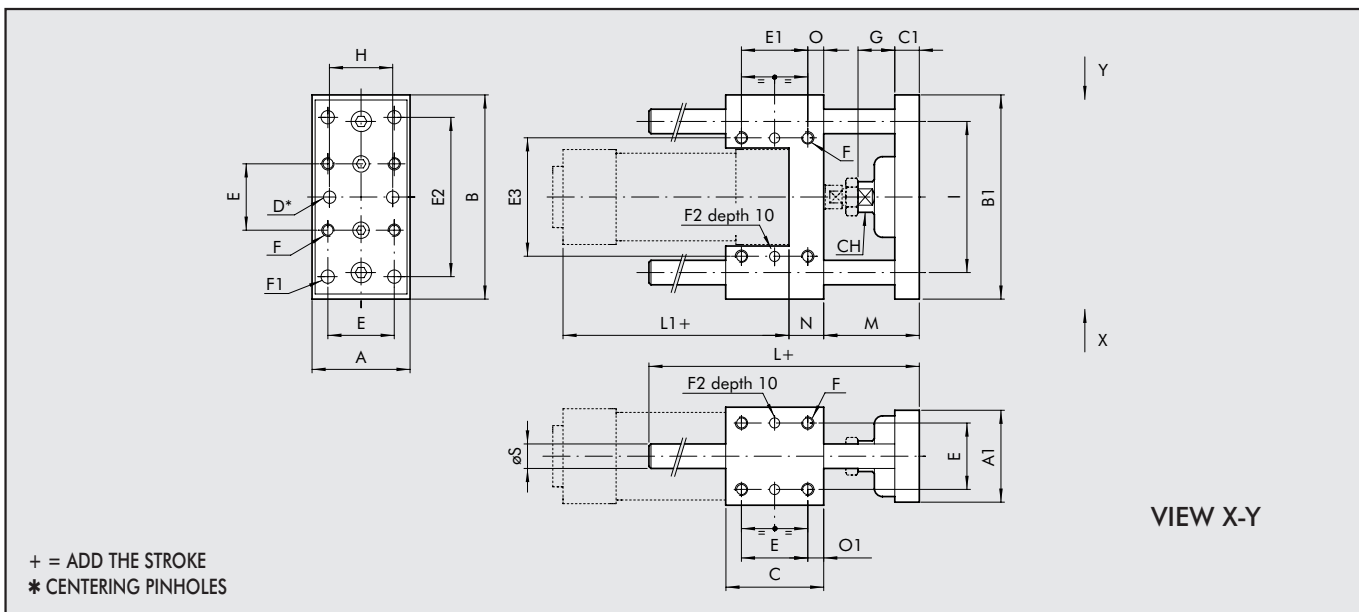

Ø	A	A ₁	B	B ₁	C	C ₁	D ^{H7}	E	E ₁	E ₂	E ₃	F	F ₁	F ₂ ^{H7}	G	H	I	L	L ₁	M	N	O	O ₁	ØS	Ch
32	48	45	100	95	48	12	6	32.5	32.5	78	58	M6	6.5	6	18	31	74	108	94	46	17	7.8	7.8	12	15
40	56	53	106	101	58	15	6	38	38	84	64	M6	6.5	6	21	36	80	120	105	52	21	10	10	12	15
50	66	63	125	120	59	15	6	46.5	46.5	100	80	M8	8.5	6	24	45	96	130	106	65	25	6.3	6.3	16	22
63	76	73	132	127	76	15	6	56.5	56.5	105	95	M8	8.5	6	24	45	104	145	121	65	25	9.8	9.8	16	22
80	98	95	165	160	90	16	6	72	50	130	130	M10	11	6	31	56	130	170	128	71	34	20	9	20	27
100	118	115	185	180	110	16	6	89	70	150	150	M10	11	6	31	56	152	190	138	71	39	20	10.5	20	27

DIMENSIONS TYPE GDH-GDM

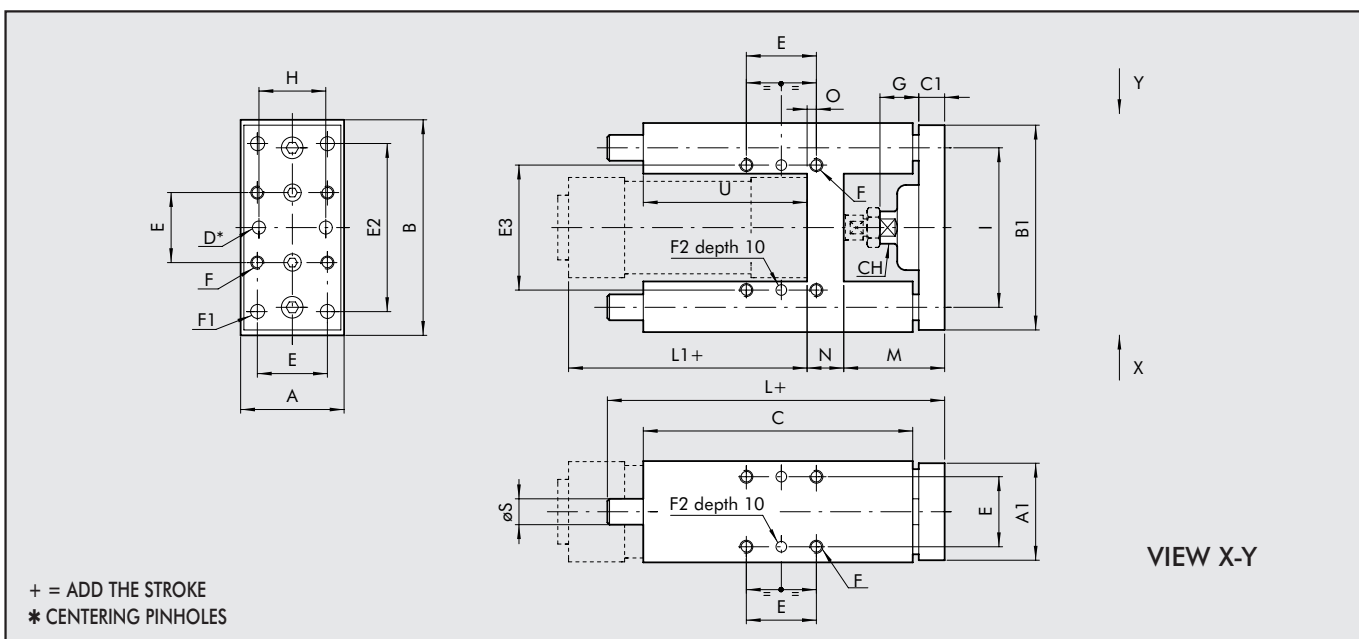

Ø	A	A ₁	B	B ₁	C	C ₁	Ch	D ^{H7}	E	E ₂	E ₃	F	F ₁	F ₂ ^{H7}	G	H	I	L	L ₁	M	N	O	ØS	U
32	49	45	97	90	125	12	13	6	32.5	78	61	M6	6.5	6	18	31	74	177	94	47	17	4.3	12	76
40	58	54	115	110	139	15	15	6	38	84	69	M6	6.5	6	21	36	87	192	105	53	21	11	16	81
50	69	63	137	130	148	15	22	6	46.5	100	85	M8	8.5	6	24	45	104	205	106	63	26	18.5	20	78
63	85	79	152	145	182	15	22	6	56.5	105	100	M8	8.5	6	24	45	119	237	121	62	26	15.3	20	111
80	105	99	189	180	215	20	27	6	72	130	130	M10	11	6	31	56	148	280	128	76	34	21	25	128
100	129	120	213	200	220	20	27	6	89	150	150	M10	11	6	31	56	172	280	138	76	39	24.5	25	128

GUIDE UNIT

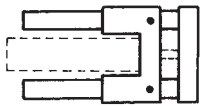
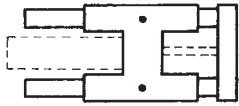
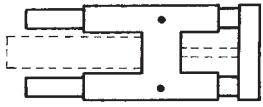
Version	Bore	Type	Code
Sliding on bronze bushings (GDS) 	32	UNIT MW DS 032...	W 0700321...
	40	UNIT MW DS 040...	W 0700401...
	50	UNIT MW DS 050...	W 0700501...
	63	UNIT MW DS 063...	W 0700631...
	80	UNIT MW DS 080...	W 0700801...
	100	UNIT MW DS 100...	W 0701001...
Sliding on bronze bushings (GDH) 	32	UNIT MW DH 032...	W 0700322...
	40	UNIT MW DH 040...	W 0700402...
	50	UNIT MW DH 050...	W 0700502...
	63	UNIT MW DH 063...	W 0700632...
	80	UNIT MW DH 080...	W 0700802...
	100	UNIT MW DH 100...	W 0701002...
Sliding on ball bearing (GDM) 	32	UNIT MW DM 032...	W 0700323...
	40	UNIT MW DM 040...	W 0700403...
	50	UNIT MW DM 050...	W 0700503...
	63	UNIT MW DM 063...	W 0700633...
	80	UNIT MW DM 080...	W 0700803...
	100	UNIT MW DM 100...	W 0701003...

Note: To complete the type and code, add the 3-digit stroke (e.g. 50=050)

DIMENSIONS PISTON ROD LOCK + GUIDE UNIT COD. 137

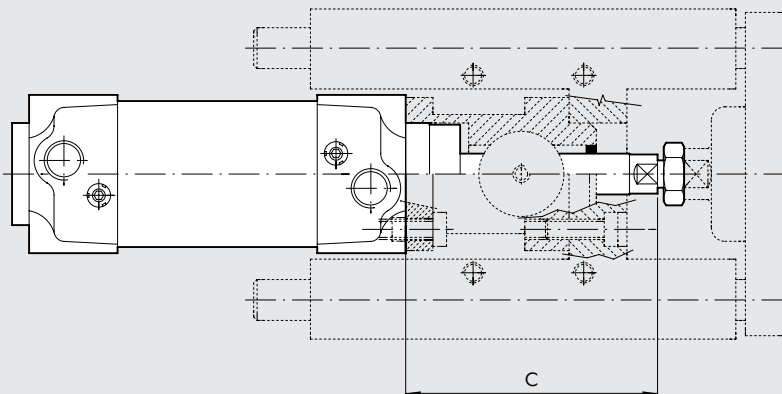

Ø	C
32	74
40	85
50	107
63	107
80	136
100	143
126	187