

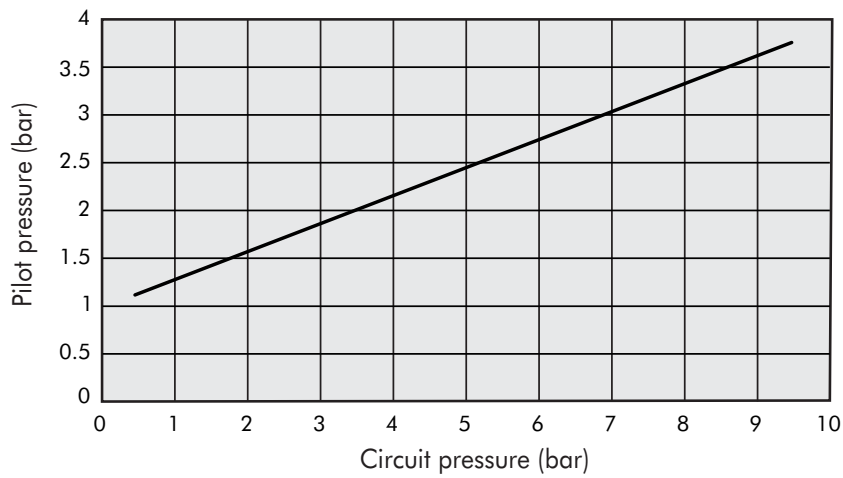

MINIMUM PILOT PRESSURE PNV L Ø6

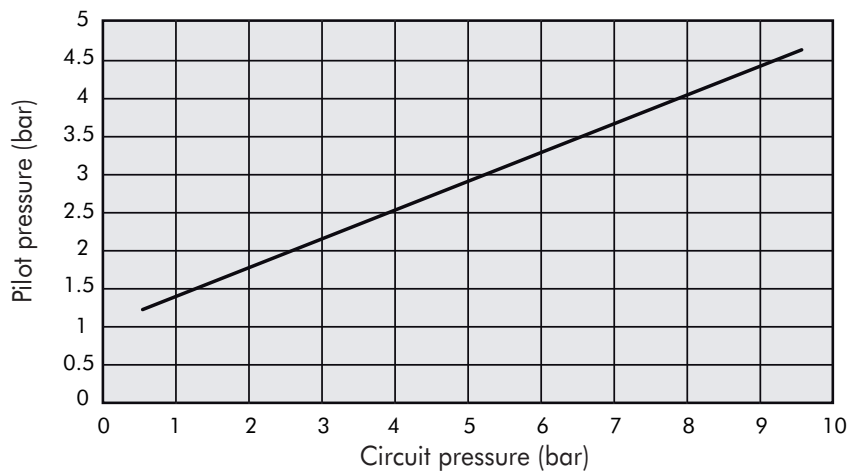

MINIMUM PILOT PRESSURE PNV L Ø8



ASSEMBLY OPTIONS

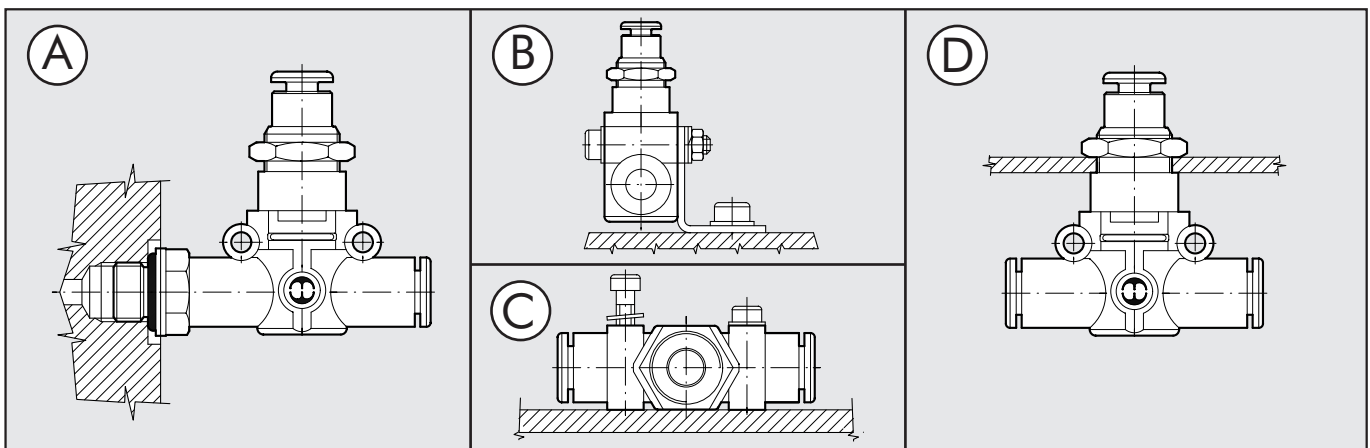

How to mount the PNV L:

- Fig. A: With the male threaded port it is possible to mount the PNV L straight onto the actuator or the control valve.
- Fig. B: Fixing to the plate with the special SQU L bracket.
- Fig. C: There are two robust rings on the plastic body for fixing the PNV L straight onto the wall.
- Fig. D: The ring nut is screwed onto the threaded metal part of the PNV L body for panel mounting.

PNV L 3/2 NC PIPE - PIPE

Code	Ref.	Ø	A	B	C	D	E	G	H	I
------	------	---	---	---	---	---	---	---	---	---

9067616	PNV L 3/2 NC Ø6 - Ø6	6	49.4	43.2	14.7	6.4	11.4	20	M12x0.75	14.6
9067624	PNV L 3/2 NC Ø8 - Ø8	8	57.3	49.7	18.7	9.1	13.8	26	M15x1	18.7

I1	CH	Nmax
----	----	------

20	15	4.7
24	17	4

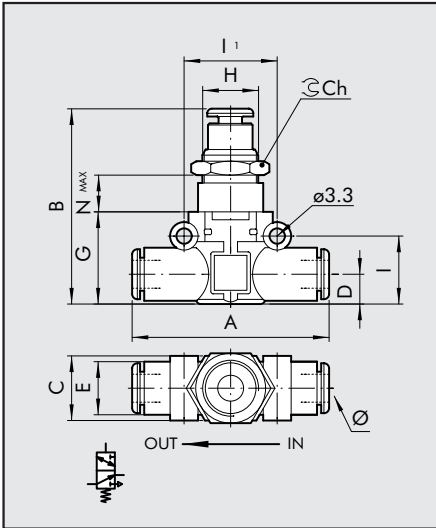

PNV L 3/2 NC PIPE - THREAD

Code	Ref.	F	Ø	P	A	A1	B	C	D	E	E1
------	------	---	---	---	---	----	---	---	---	---	----

9067808	PNV L 3/2 NC Ø6 - 1/8	1/8	6	6	58.5	27.8	43.2	14.7	6.4	14	11.4
9067809	PNV L 3/2 NC Ø6 - 1/4	1/4	6	8	61.5	28.8	43.2	14.7	6.4	18	11.4
9067810	PNV L 3/2 NC Ø8 - 1/8	1/8	8	6	66.2	31.8	49.7	18.7	9.1	15	13.8
9067811	PNV L 3/2 NC Ø8 - 1/4	1/4	8	8	70.6	34.2	49.7	18.7	9.1	18	13.8
9067812	PNV L 3/2 NC Ø8 - 3/8	3/8	8	9	72.2	34.8	49.7	18.7	9.1	22	13.8

G	H	I	I1	CH	Nmax
---	---	---	----	----	------

20	M12x0.75	14.6	20	15	4.7
20	M12x0.75	14.6	20	15	4.7
26	M15x1	18.7	24	17	4
26	M15x1	18.7	24	17	4
26	M15x1	18.7	24	17	4

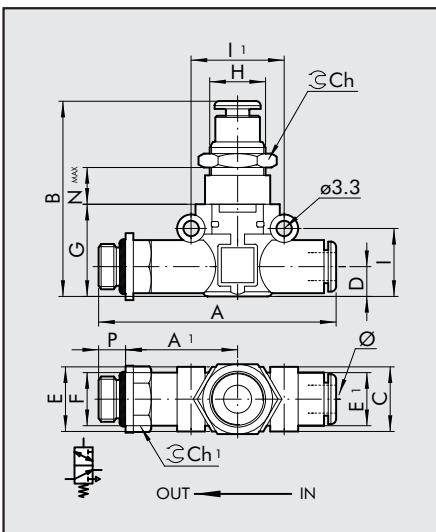

PNV L 3/2 NC THREAD - PIPE

Code	Ref.	Ø	F	P	A	A1	B	C	D	E	E1
------	------	---	---	---	---	----	---	---	---	---	----

9067708	PNV L 3/2 NC 1/8 - Ø6	6	1/8	6	58.5	27.8	43.2	14.7	6.4	14	11.4
9067709	PNV L 3/2 NC 1/4 - Ø6	6	1/4	8	61.5	28.8	43.2	14.7	6.4	18	11.4
9067710	PNV L 3/2 NC 1/8 - Ø8	8	1/8	6	66.2	31.8	49.7	18.7	9.1	15	13.8
9067711	PNV L 3/2 NC 1/4 - Ø8	8	1/4	8	70.6	34.2	49.7	18.7	9.1	18	13.8
9067712	PNV L 3/2 NC 3/8 - Ø8	8	3/8	9	72.2	34.8	49.7	18.7	9.1	22	13.8

G	H	I	I1	CH	Nmax
---	---	---	----	----	------

20	M12x0.75	14.6	20	15	4.7
20	M12x0.75	14.6	20	15	4.7
26	M15x1	18.7	24	17	4
26	M15x1	18.7	24	17	4
26	M15x1	18.7	24	17	4

