

IN-LINE FIXED-REGULATION FLOW REGULATOR Serie RFF L

The in-line fixed regulation flow regulator belongs to the LINE ON LINE® family and can be connected in series or in parallel with the other products in the same family. The RFF L regulates the flow of air, and hence the rate of operation of pneumatic actuators. Air flow is regulated by means of a choke with a calibrated diameter. A full range of diameters is available.

The advantage of the RFF L over other adjustable versions is that there is no need for regulation during machine installation. Subsequent adjustments are not required either. Two versions are available. Version U (unidirectional) regulates the flow in one direction only. Version B (bidirectional) regulates the air flow in both directions. The flow regulator can be mounted in three different ways (see next page).



TECHNICAL DATA		Ø 4	Ø 6	Ø 8
Max. operating pressure	MPa		1	
	bar		10	
Temperature range	psi		145	
	°C		-20 ÷ +60	
	°F		-4 ÷ +140	
Choke flow rate	NI/min		see table	
Recommended pipe			Rilsan PA 11 – Nylon 6 – Polyamide 12 - Polypropylene	
Fluid			Lubricated or unlubricated filtered air	
Compatibility with oils:			see GENERAL CATALOGUE page 6.1/08 or webpage www.metalwork.it/eng/materiali_compatibilita.html	

EXHAUST FLOW RATE AT 6.3 bar (NI/min)			
Choke (mm)	Ø4	Ø6	Ø8
Ø 0.2	142	552	912
Ø 0.3	144	554	914
Ø 0.4	147	557	917
Ø 0.5	153	563	923
Ø 0.6	155	565	925
Ø 0.8	172	582	942
Ø 1.0	190	600	960
Ø 1.3	225	635	995
Ø 1.5	250	660	1020

CHOKE FLOW-RATE AT 6 bar WITH RELIEF VALVE OPEN	
Choke (mm)	Flow rate (NI/min)
Ø 0.2	2
Ø 0.3	4
Ø 0.4	7
Ø 0.5	13
Ø 0.6	15
Ø 0.8	32
Ø 1.0	50
Ø 1.3	85
Ø 1.5	110

COMPONENTS

- ① Technopolymer body
- ② Nickel-plated brass gasket holding insert
- ③ NBR gasket
- ④ Brass choke cartridge
- ⑤ NBR seal
- ⑥ Technopolymer spring ring
- ⑦ Stainless steel clip-on spring
- ⑧ Technopolymer stop bushing
- ⑨ Technopolymer release bushing

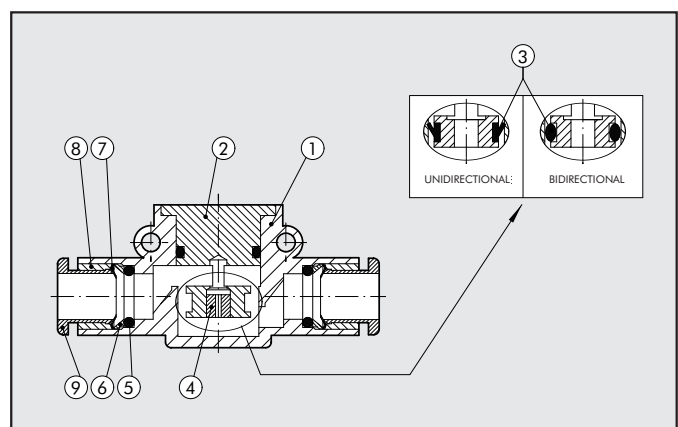



ASSEMBLY OPTIONS

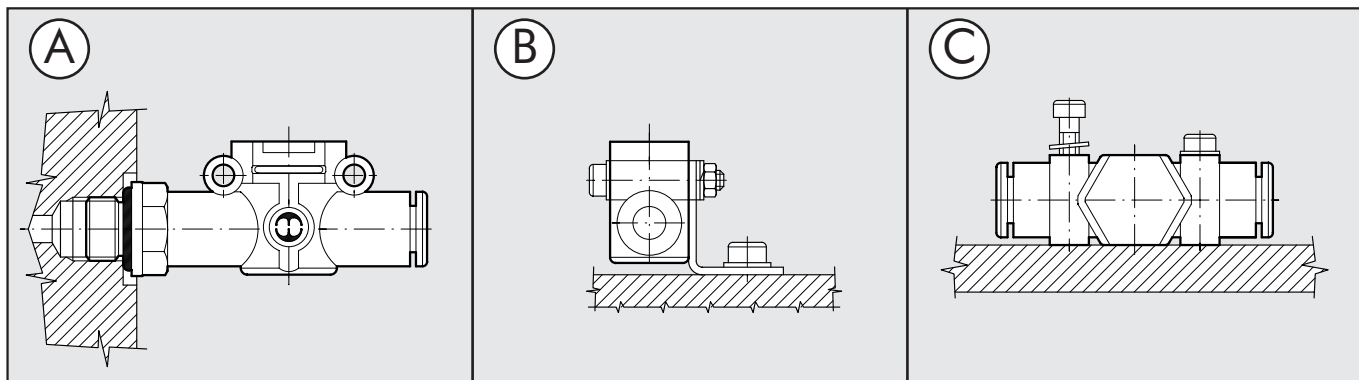

How to mount the RFF L:

- Fig. A: With the male threaded port it is possible to mount the RFF L straight onto the actuator or the control valve.
- Fig. B: Fixing to the plate with the special SQU L bracket.
- Fig. C: There are two robust rings on the plastic body for fixing the RFF L straight onto the wall.

RFF L PIPE - PIPE UNIDIRECTIONAL

Code	Ref.	Ø	A	B	C	D	E	I	II
------	------	---	---	---	---	---	---	---	----

9070U11_*	RFF-U L 4-4	4	42	17.5	10.7	5.6	10	12.8	16
9070U22_*	RFF-U L 6-6	6	49.4	20	14.7	6.4	11.4	14.6	20
9070U33_*	RFF-U L 8-8	8	57.3	25.5	18.7	9.1	13.8	18.7	24

* The last two digits indicate the narrowing Ø. To complete the code please look at the key to codes.

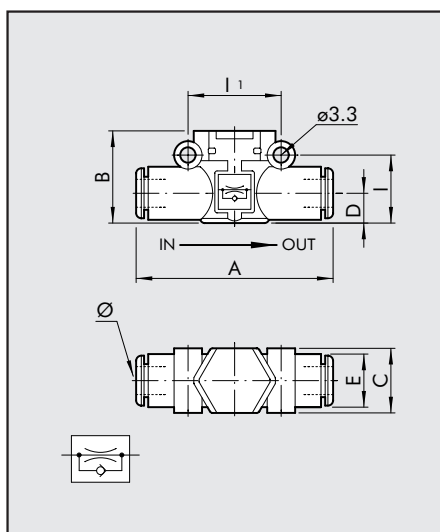

RFF L THREAD - PIPE UNIDIRECTIONAL CYLINDER VERSION

Code	Ref.	F	Ø	P	A	A1	B	C	E	E1	I	II	Ch
------	------	---	---	---	---	----	---	---	---	----	---	----	----

9070C51_*	RFF-C L M5 - Ø4	M5	4	4	47.7	22.7	17.5	10.7	9.9	10	12.8	16	9
9070C61_*	RFF-C L 1/8" - Ø4	1/8	4	6	51.6	24.6	17.5	10.7	14	10	12.8	16	12
9070C62_*	RFF-C L 1/8" - Ø6	1/8	6	6	58.5	27.8	20	14.7	14	11.4	14.6	20	12
9070C72_*	RFF-C L 1/4" - Ø6	1/4	6	8	61.5	28.8	20	14.7	18	11.4	14.6	20	14
9070C63_*	RFF-C L 1/8" - Ø8	1/8	8	6	66.2	31.8	25.5	18.7	15	13.8	18.7	24	14
9070C73_*	RFF-C L 1/4" - Ø8	1/4	8	8	70.6	34.2	25.5	18.7	18	13.8	18.7	24	14
9070C83_*	RFF-C L 3/8" - Ø8	3/8	8	9	72.2	34.8	25.5	18.7	22	13.8	18.7	24	17

* The last two digits indicate the narrowing Ø. To complete the code please look at the key to codes.

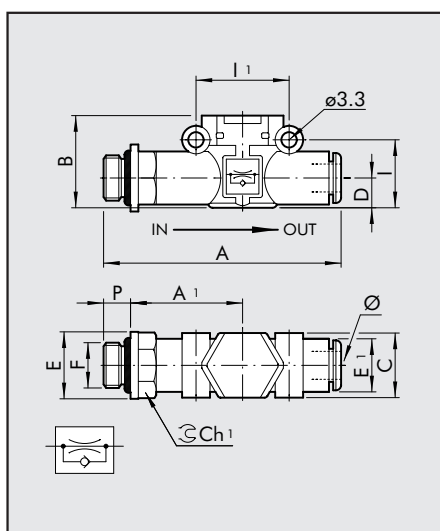

RFF L PIPE - THREAD UNIDIRECTIONAL VALVE VERSION

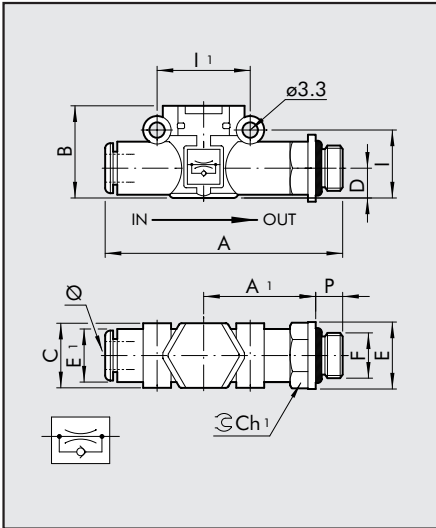

Code	Ref.	Ø	F	P	A	A1	B	C	E	E1	I	I1	Ch
9070V15_*	RFF-V L Ø4 - M5	4	M5	4	47.7	22.7	17.5	10.7	9.9	10	12.8	16	9
9070V16_*	RFF-V L Ø4 - 1/8"	4	1/8	6	51.6	24.6	17.5	10.7	14	10	12.8	16	12
9070V26_*	RFF-V L Ø6 - 1/8"	6	1/8	6	58.5	27.8	20	14.7	14	11.4	14.6	20	12
9070V27_*	RFF-V L Ø6 - 1/4"	6	1/4	8	61.5	28.8	20	14.7	18	11.4	14.6	20	14
9070V36_*	RFF-V L Ø8 - 1/8"	8	1/8	6	66.2	31.8	25.5	18.7	15	13.8	18.7	24	14
9070V37_*	RFF-V L Ø8 - 1/4"	8	1/4	8	70.6	34.2	25.5	18.7	18	13.8	18.7	24	14
9070V38_*	RFF-V L Ø8 - 3/8"	8	3/8	9	72.2	34.8	25.5	18.7	22	13.8	18.7	24	17

* The last two digits indicate the narrowing Ø. To complete the code please look at the key to codes.

RFF L PIPE - PIPE BIDIRECTIONAL

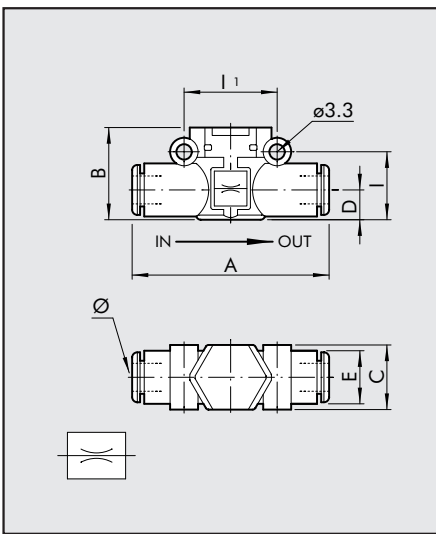

Code	Ref.	Ø	A	B	C	D	E	I	I1
9070B11_*	RFF-B L 4-4	4	42	17.5	10.7	5.6	10	12.8	16
9070B22_*	RFF-B L 6-6	6	49,4	20	14.7	6.4	11.4	14.6	20
9070B33_*	RFF-B L 8-8	8	57,3	25.5	18.7	9.1	13.8	18.7	24

* The last two digits indicate the narrowing Ø. To complete the code please look at the key to codes.

RFF L THREAD - PIPE BIDIRECTIONAL

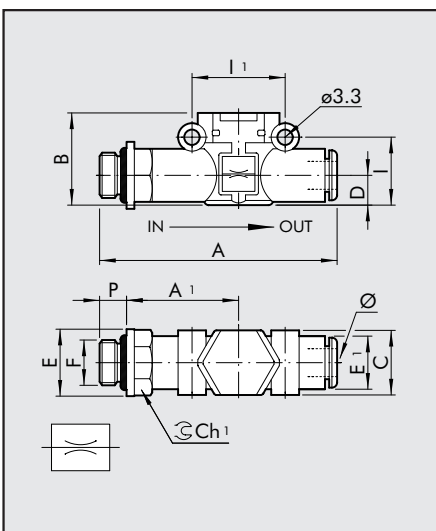

Code	Ref.	F	Ø	P	A	A1	B	C	E	E1	I	I1	Ch
9070B51_*	RFF-B L M5 - Ø4	M5	4	4	47.7	22.7	17.5	10.7	9.9	10	12.8	16	9
9070B61_*	RFF-B L 1/8" - Ø4	1/8	4	6	51.6	24.6	17.5	10.7	14	10	12.8	16	12
9070B62_*	RFF-B L 1/8" - Ø6	1/8	6	6	58.5	27.8	20	14.7	14	11.4	14.6	20	12
9070B72_*	RFF-B L 1/4" - Ø6	1/4	6	8	61.5	28.8	20	14.7	18	11.4	14.6	20	14
9070B63_*	RFF-B L 1/8" - Ø8	1/8	8	6	66.2	31.8	25.5	18.7	15	13.8	18.7	24	14
9070B73_*	RFF-B L 1/4" - Ø8	1/4	8	8	70.6	34.2	25.5	18.7	18	13.8	18.7	24	14
9070B83_*	RFF-B L 3/8" - Ø8	3/8	8	9	72.2	34.8	25.5	18.7	22	13.8	18.7	24	17

* The last two digits indicate the narrowing Ø. To complete the code please look at the key to codes.



KEY TO CODING

9 0 7 0	B	11	02
TYPE	FUNCTION	Ø IN - Ø OUT	Ø CHOKE
9070 RFF L	B Bidirectional C for cylinder U Unidirectional V for valve	■ 11 = Ø4 - Ø4 * 15 = Ø4 - M5 * 16 = Ø4 - 1/8" ■ 22 = Ø6 - Ø6 * 26 = Ø6 - 1/8" * 27 = Ø6 - 1/4" ■ 33 = Ø8 - Ø8 * 36 = Ø8 - 1/8" * 37 = Ø8 - 1/4" * 38 = Ø8 - 3/8" ● 51 = M5 - Ø4 ● 61 = 1/8" - Ø4 ● 62 = 1/8" - Ø6 ● 63 = 1/8" - Ø8 ● 72 = 1/4" - Ø6 ● 73 = 1/4" - Ø8 ● 83 = 3/8" - Ø8	02 = Ø0.2 03 = Ø0.3 04 = Ø0.4 05 = Ø0.5 06 = Ø0.6 08 = Ø0.8 10 = Ø1.0 13 = Ø1.3 15 = Ø1.5

■ Only for **B** (bidirectional) and **U** (unidirectional) versions
***** Only for **V** (valve) versions
● Only for **C** (cylinder) and **V** (valve) versions

LINE ON LINE® ACCESSORIES

FIXING SQUARE KIT

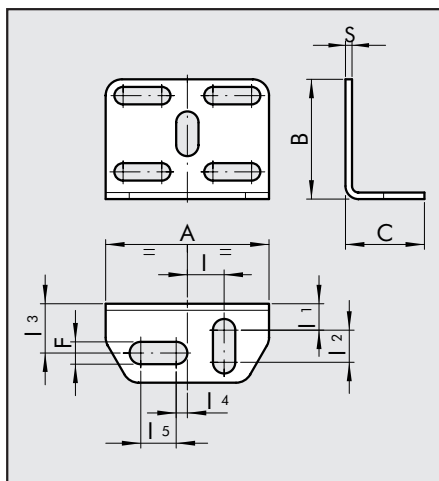

Code	Description	A	B	C	F	I	11	12	13	14	15	S
9062110	SQU L	30	22	14.5	4.2	6.8	4.8	5.9	9.1	2	6.5	1.2

NOTE: comes with two m3x16 screws (for L.O.L. Ø 6 - 8), two m3 hexagonal nuts, 2 groovers, 4 washers.

U-BOLT

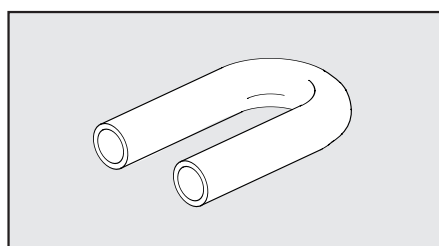

Code	Description
9062216	TUB L 6-6
9062224	TUB L 8-8

METAL WORK S.p.A

Head office: Via Segni, 5-7-9 25062 - Concesio (Brescia) Italy - Tel. 030 21 87 11 - Fax 030 21 80 569
 www.metalwork.it - metalwork@metalwork.it

The dimensions shown in this catalogue are subject to variations at any time without prior notice