

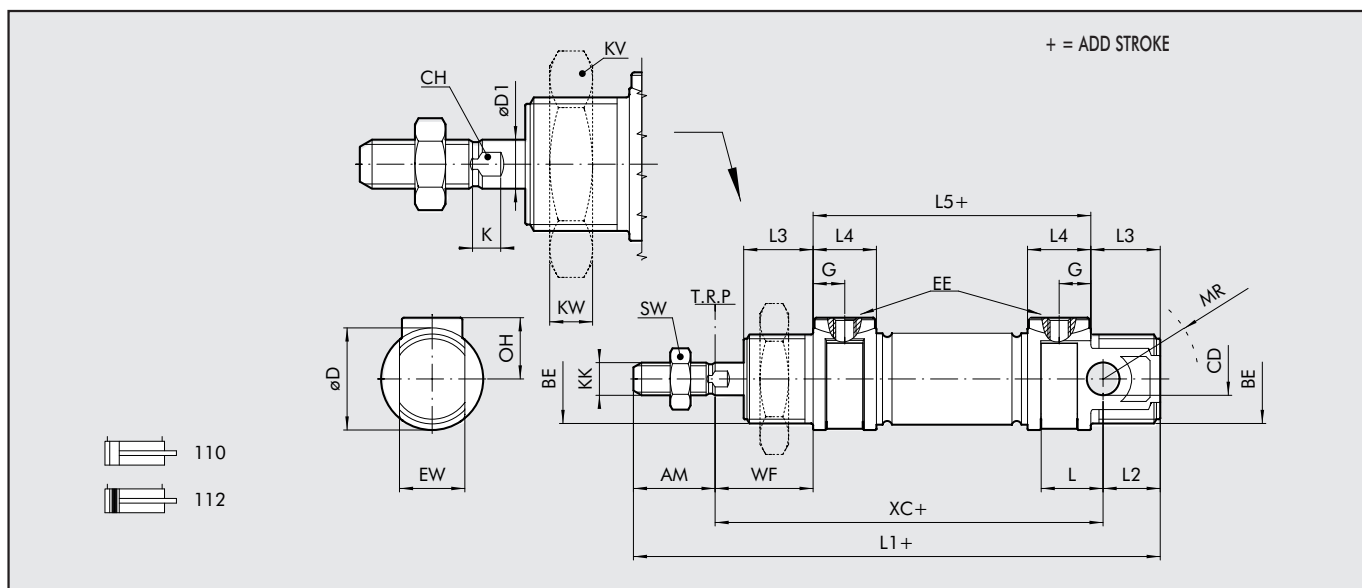



## DIMENSIONS OF STANDARD VERSIONS



Ø	AM	BE	CD (H9)	øD	øD1	G	EE	EW (d13)	OH	L	L1	L2	L3	L4	L5	KK	XC(±1)	WF	KW	KV	MR	SW	CH	K
16	16	M16x1.5	6	21	6	4.7	M5	12	12	11	111	13	17	9.5	56	M6	82	22	8	24	16	10	5	3.5
20	20	M22x1.5	8	25	8	7.7	1/8"	16	16	15	129	14	17	15.5	68	M8	95	24	7	32	18	13	7	4.6
25	22	M22x1.5	8	30	10	7.7	1/8"	16	17	15	143	17	20	15.5	73	M10x1.25	104	28	7	32	21	17	8	5.5

MAX LOCKING TORQUE [Nm]		
Ø	BE (front/rear)	EE
16	12/8	1.2
20	22/15	3
25	22/15	3

## DIMENSIONS OF STANDARD VERSIONS WITH THROUGH-ROD

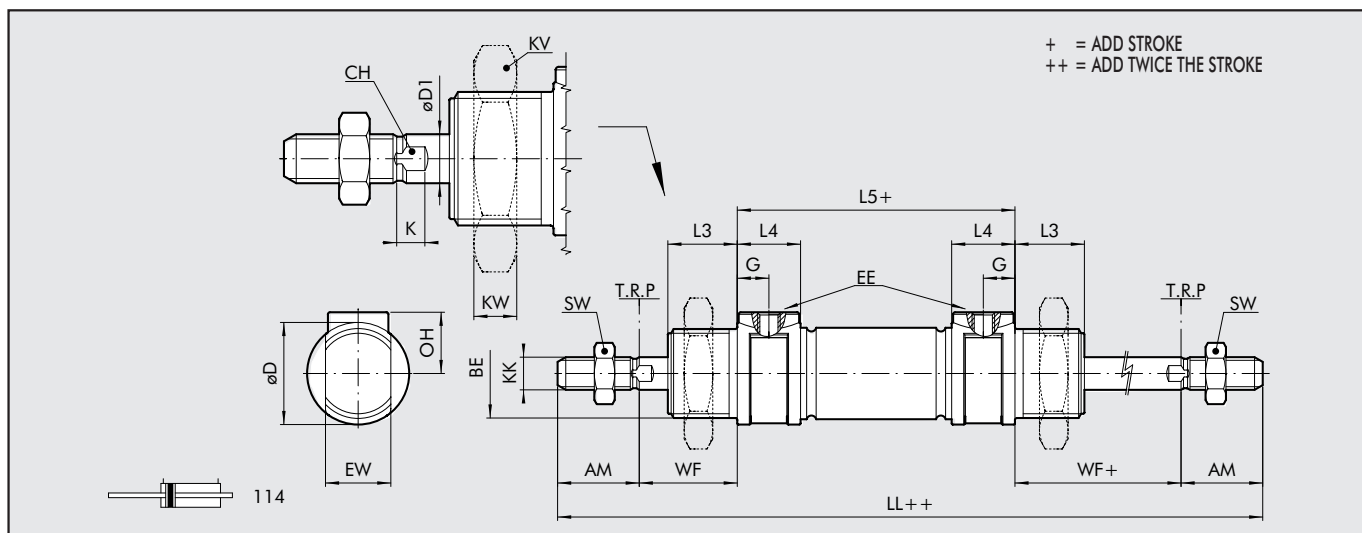

Ø	AM	BE	øD	øD1	G	EE	OH	LL	L3	L4	L5	KK	WF	KW	KV	SW	CH	K
16	16	M16x1.5	21	6	4.7	M5	12	132	17	9.5	56	M6	22	8	24	10	5	3.5
20	20	M22x1.5	25	8	7.7	1/8"	16	156	17	15.5	68	M8	24	7	32	13	7	4.6
25	22	M22x1.5	30	10	7.7	1/8"	17	173	20	15.5	73	M10x1.25	28	7	32	17	8	5.5

MAX LOCKING TORQUE [Nm]		
Ø	BE	EE
16	12	1.2
20	22	3
25	22	3

### KEY TO CODES

CYL	1	1	0	3	1	6	0	0	2	0	C	P		
	TYPE			DIAMETER			STROKE			CONFIGURATION				
	<b>110</b>	DE non-magnetic minicylinder		● <b>3</b>	TP heads (standard)	■ <b>16</b>	<b>0</b>	Standard	For the maximum suppliable strokes, look at the technical data			<b>C</b>	C45 chrome rod	
	<b>112</b>	DEM minicylinder		<b>4</b>	TP heads (standard) + head nut	<b>20</b>	<b>S</b>	Non-magnetic			<b>X</b>	Stainless rod	<b>P</b>	polyurethane
	<b>114</b>	DEM through-rod minicylinder				<b>25</b>								

As standard the cylinders are already stick-slip version.

- This version don't provide the nut on the head.
- ø16 will be only in version with stainless rod (X).

**DE:** Double-acting (non-cushioned, not magnetic).

**DEM:** Double action magnetic (unless otherwise specified) not cushioned.

## ACCESSORIES: FIXINGS

### FOOT MODEL A

Code      Ø D   XS (±1.4)   AU   AO   NH (±0.3)   TR (Js14)   US   AB (H13)   R   S   Weight [g]

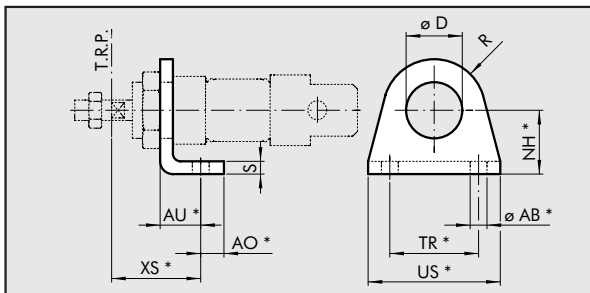

W0950120001	16	16	32	14	6	20	32	42	5.5	13	4	42
W0950200001	20	22	36	17	8	25	40	54	6.5	20	5	90
W0950200001	25	22	40	17	8	25	40	54	6.5	20	5	90

\*ISO 6432 values

Note: Individually packed

### FLANGE MODEL C

Code      Ø D   W (±1.4)   FB (H13)   TF (Js14)   UF   UR   S   Weight [g]

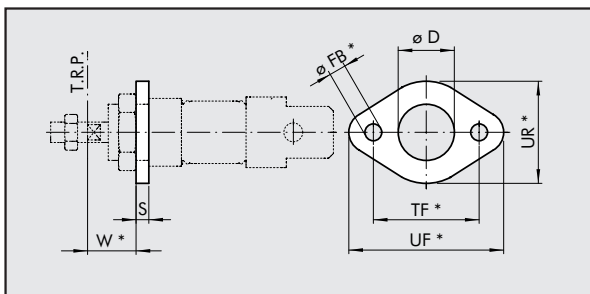

W0950120002	16	16	18	5.5	40	52	30	4	26
W0950200002	20	22	19	6.5	50	66	40	5	52
W0950200002	25	22	23	6.5	50	66	40	5	52

\*ISO 6432 values

Note: Individually packed

### COUNTER-HINGE MODEL BC

Code      Ø   AO   LG   TR (Js13)   NH (±0.2)   MO   AB1   AB (H13)   R   S   Weight [g]

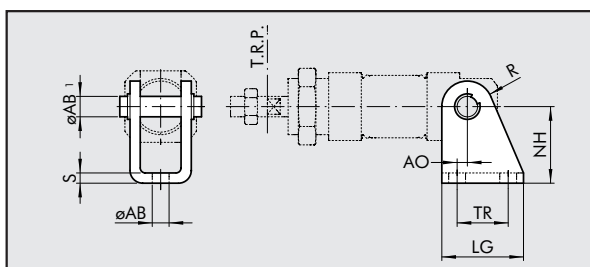

W0950120005	16	2	25	15	27	25	6	5.5	7	3	40
W0950200005	20	4	32	20	30	30	8	6.5	10	4	78
W0950200005	25	4	32	20	30	30	8	6.5	10	4	78

Note: Supplied complete with 1 pin and 2 snap rings



**NUT FOR HEADS MODEL D**

Code      Ø      F      CH      H      Weight [g]

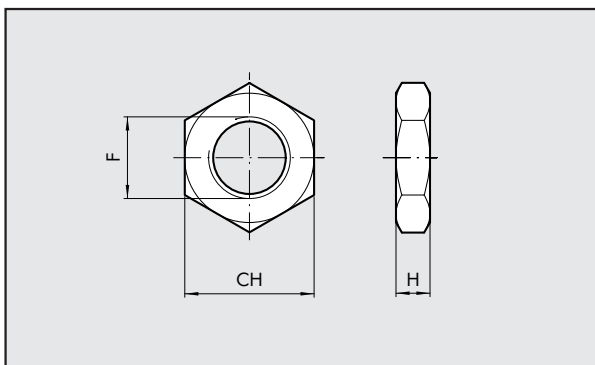

0950120010	16	M16x1.5	24	8	20
0950200010	20	M22x1.5	32	7	44
0950200010	25	M22x1.5	32	7	44

Note: Individually packed

**NUT FOR PISTON RODS MODEL DA**

Code      Ø      F      CH      H      Weight [g]

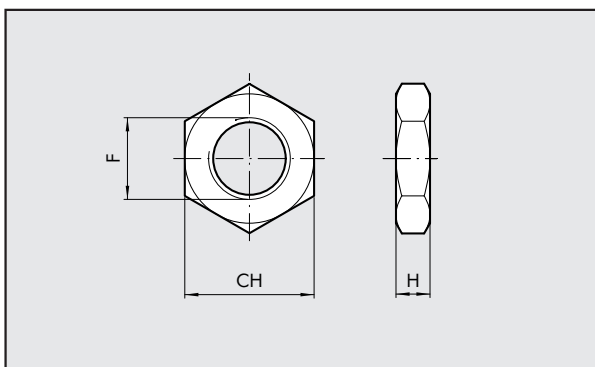

0950120011	16	M6	10	4	1
0950200011	20	M8	13	5	3
0950322010	25	M10x1.25	17	6	7

Note: Individually packed

**FORK MODEL GK-M**

Code      Ø      Ø M      C      B      A      L      F      D      N      Weight [g]

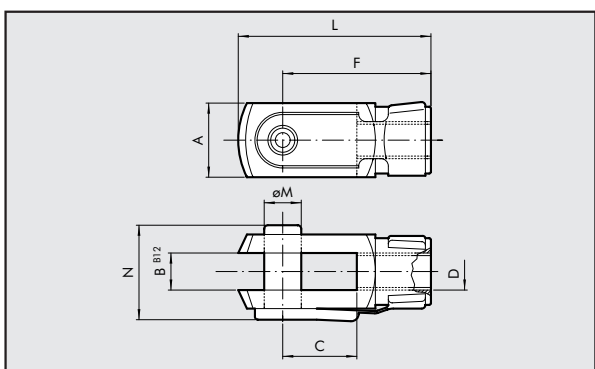

W0950120020	16	6	12	6	12	31	24	M6	16	20
W0950200020	20	8	16	8	16	42	32	M8	22	48
W0950322020	25	10	20	10	20	52	40	M10x1.25	26	92

Note: Individually packed

**ROD EYE MODEL GA-M**

Code      Ø      Ø M      C      B      B1      A      L      F      D      øG      øG1      CH      Weight [g]

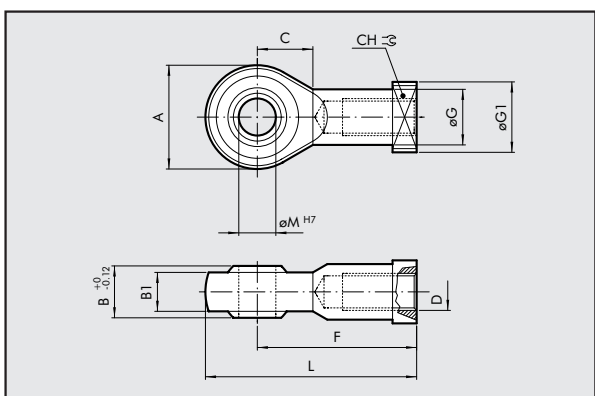

W0950120025	16	6	11	9	6.75	20	40	30	M6	10	13	11	28
W0950200025	20	8	13	12	9	24	48	36	M8	12.5	16	14	50
W0950322025	25	10	15	14	10.5	28	57	43	M10x1.25	15	19	17	78

Note: Individually packed

## ACCESSORIES: MAGNETIC SENSORS

### RETRACTABLE SENSOR WITH INSERTION FROM ABOVE

Code Description

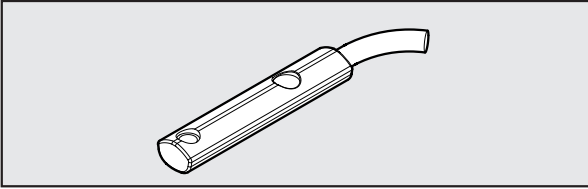

W0952025390	HALL N.O. SENSOR, VERTICAL INSERTION 2.5m
W0952029394	HALL N.O. SENSOR, VERTICAL INSERTION 300 mm M8
W0952022180	REED N.O. SENSOR, VERTICAL INSERTION 2.5m
W0952028184	REED N.O. SENSOR, VERTICAL INSERTION 300 mm M8
W0952125556	HALL N.O. SENSOR, VERTICAL INSERTION 2m ATEX

Note: Individually packed

### WIRING DIAGRAM

### TECHNICAL DATA

### ATEX

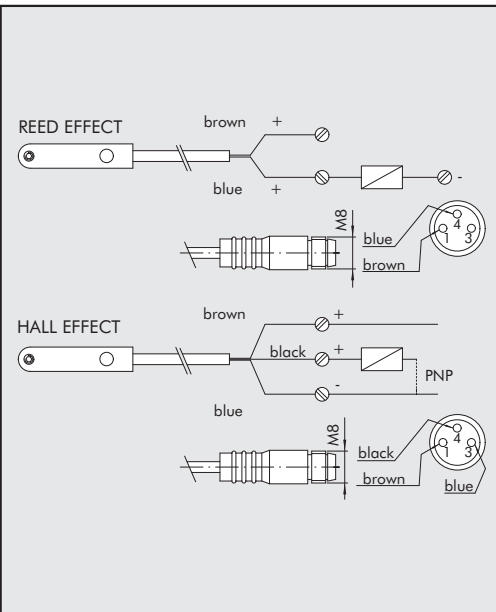

	Reed	Effetto Hall	Effetto Hall
Type of contact	N.O.	N.O.	N.O.
Switch	-	PNP	PNP
Supply voltage (U <sub>b</sub> )	V 10 ÷ 30 AC/DC	10 ÷ 30 DC	18 ÷ 30 DC
Power	W 3 (peak valve=6)	3	≤ 1.7
Voltage variation	-	≤ 10% di U <sub>b</sub>	≤ 10% di U <sub>b</sub>
Voltage drop	V -	≤ 2	≤ 2.2
Input current	mA -	≤ 10	≤ 10
Output current	mA ≤ 100	≤ 100	≤ 70
Switching frequency	Hz ≤ 400	≤ 5000	1000
Short-circuit protection	-	Yes	Yes
Over-voltage suppression	-	Yes	Yes
Polarity inversion protection	-	Yes	Yes
EMC	EN 60 947-5-2	EN 60 947-5-2	EN 60 947-5-2
LED display	Yellow	Yellow	Yellow
Magnetic sensitivity	2,8 mT ±25%	2,8 mT ±25%	2.6
Repeatability	≤ 0,1 mT	≤ 0,1 mT	≤ 0,1 (U <sub>b</sub> and ta fixed)
Degree of protection (EN 60529)	IP 67	IP 67	IP 68, IP 69K
Vibration and shock resistance	30 g, 11 ms, 10÷55 Hz, 1mm	30 g, 11 ms, 10÷55 Hz, 1mm	30 g, 11 ms, 10÷55 Hz, 1mm
Temperature range	°C -25 ÷ +75	-25 ÷ +75	-20 ÷ +45
Sensor capsule material	PA66 + PA6I/6T	PA66 + PA6I/6T	PA
2.5m/2m connecting cable	PVC; 2 x 0,12 mm <sup>2</sup>	PVC; 3 x 0,14 mm <sup>2</sup>	PVC; 3 x 0,12 mm <sup>2</sup>
Connecting cable with M8x1	Polyurethane; 2 x 0,14 mm <sup>2</sup>	Polyurethane; 3 x 0,14 mm <sup>2</sup>	-
Wire NO.	2	3	3

### SENSOR CIRCLIP MOD. DSW

Code Bore Model Ø ØB C D E F

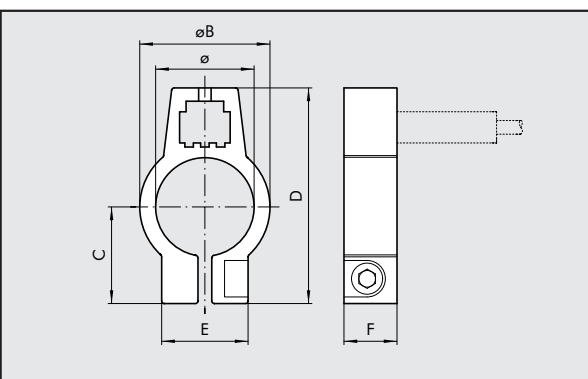

W0950000616	16	CIRCLIP DSW - 16	17.3	20.3	15.5	32	12.3	9
W0950000620	20	CIRCLIP DSW - 20	21.3	24.3	17.5	36	14	9
W0950000625	25	CIRCLIP DSW - 25	26.3	29.3	20	41.5	14	9

Note: Individually packed

### UNIVERSAL SENSOR CIRCLIP

Code Bore Model

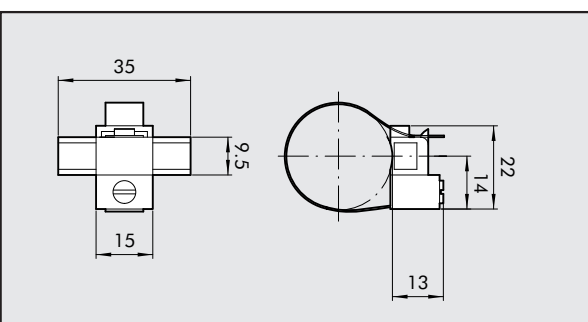

W0950001103	16÷25	SENSOR CIRCLIP
-------------	-------	----------------

Note: Individually packed

#### MATERIAL

Circlip: stainless steel  
Sensor holder: plastic

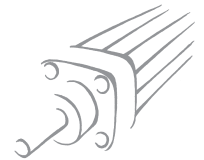

# GUIDE UNIT FOR ISO 6432 CYLINDERS

1

Guide units series DS-DH-DM ensure optimal alignment and anti-rotation effect of the pneumatic cylinder connected to it. The guide units can be used separately or combined in order to get complete handling units: in which case the guide units can be coupled using the type A and C anchorage (foot and flange).

The guide unit can be coupled to ISO 6432 cylinders ( $\varnothing 16 \div \varnothing 25$ ). The following versions are available:

U PROFILE\*: for limited loads and speeds (GDS)

H PROFILE\*: for high loads (GDH)

H PROFILE\*\*: for high speeds (GDM)

(For weights, see GENERAL CATALOGUE page 9).

## GUIDE UNIT LOAD DIAGRAM

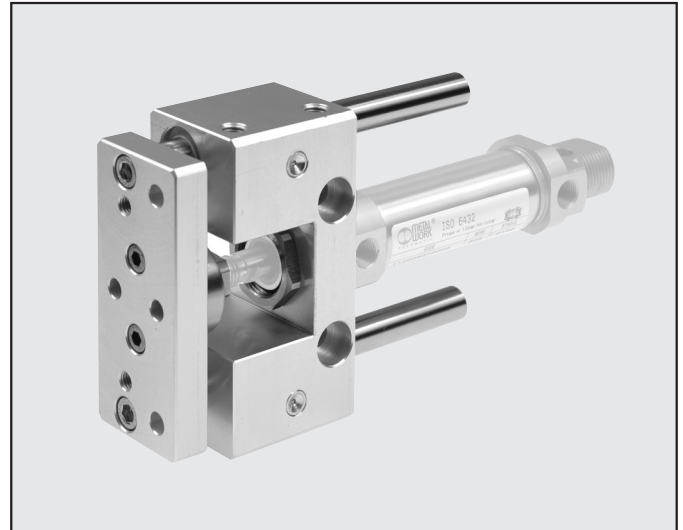

\*With bronze guide bushing

\*\*With ball guide bushing

## GUIDE ELEMENTS

SERIES GDS-GDH	Body:	aluminium alloy
	Guide bushing:	self-lubricating sintered bronze and wiper rings
	Piston rod:	chromed rolled steel
SERIES GDM	Body:	aluminium alloy
	Guide bushing:	linear guide ball bearings and wiper rings
	Piston rod:	tempered and chromed steel

## LOAD DIAGRAM

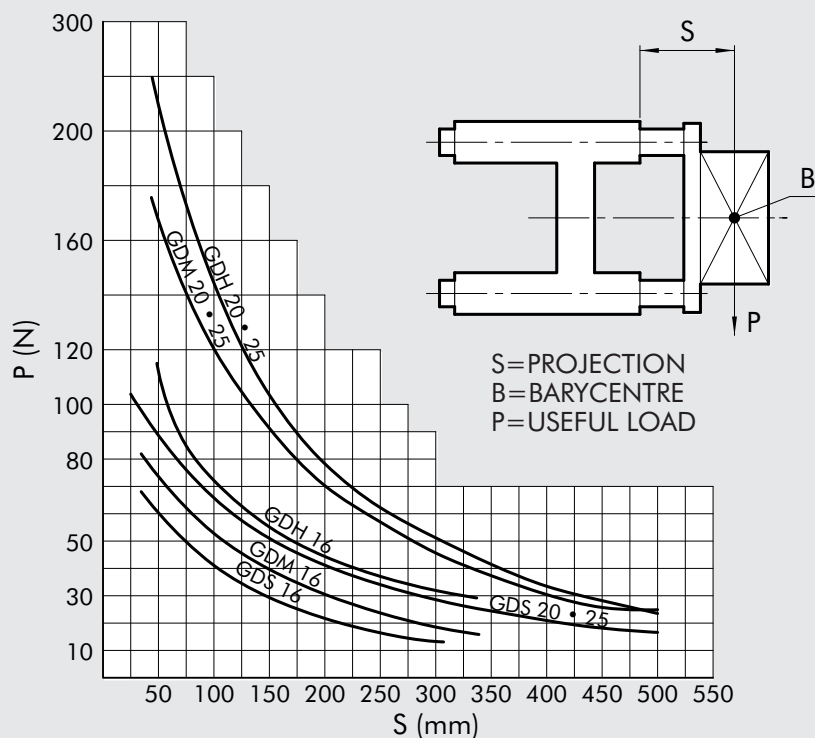

**DIMENSIONS OF TYPE GDH-GDM**

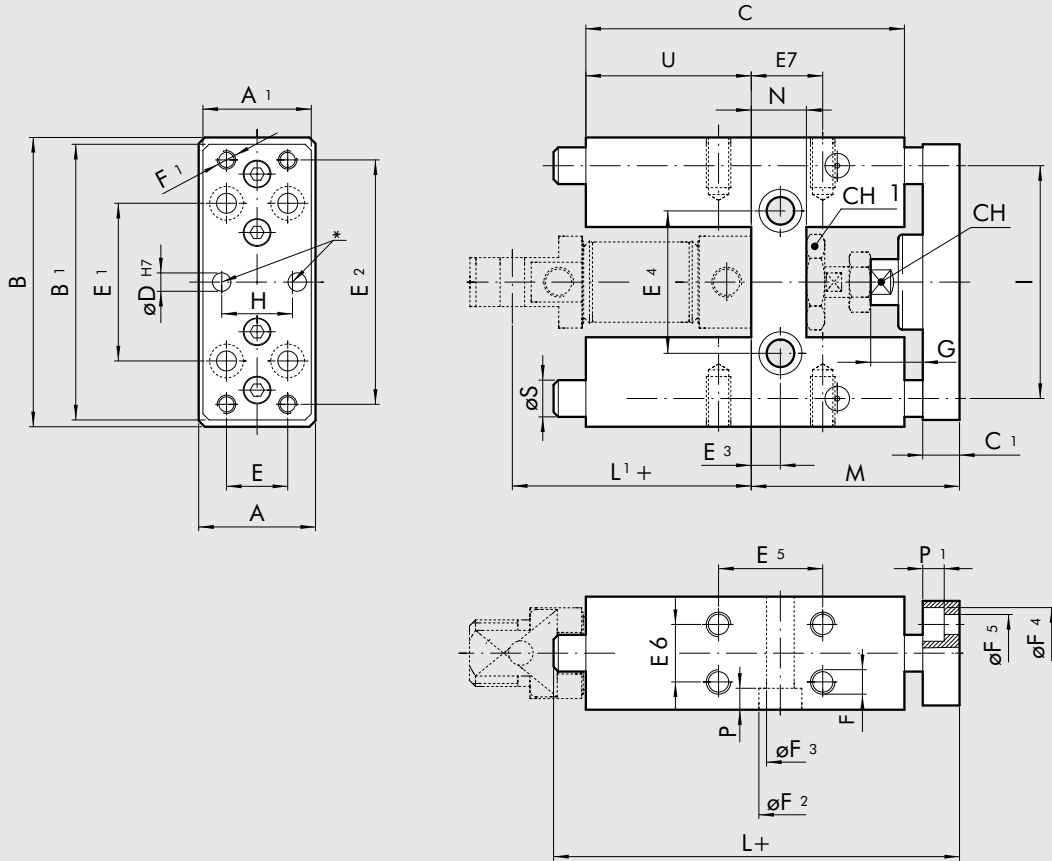

+ = ADD THE STROKE  
 \* = CENTERING PINHOLES

Ø	A	A <sub>1</sub>	B	B <sub>1</sub>	C	C <sub>1</sub>	Ch	Ch <sub>1</sub>	D	E	E <sub>1</sub>	E <sub>2</sub>	E <sub>3</sub>	E <sub>4</sub>	E <sub>5</sub>	E <sub>6</sub>	E <sub>7</sub>	F	F <sub>1</sub>	F <sub>2</sub>	F <sub>3</sub>	F <sub>4</sub>	F <sub>5</sub>	G	H	I	L	L <sub>1</sub>	M	N	P	S	U
16	30	27	65	63	75	10	8	19	4	15	32	54	6.5	24	32.5	22	11	M4	M4	8.5	5.1	7.5	4.5	15	15	46	130	60	54	15	5.5	10	37
20	34	32	79	76	108	12	13	27	6	20	40	68	8.5	38	32.5	23	15	M6	M5	10.5	6.5	9	5.5	22	20	58	160	71	65	15	7	12	58
25	34	32	79	76	108	12	13	27	6	20	40	68	8.5	38	32.5	23	15	M6	M5	10.5	6.5	9	5.5	22	20	58	160	76	65	15	7	12	58

**Note:**  
 Thanks to the dimensional features, it is possible to extend the use of GDH/GDM guides to cylinders with strokes up to 25 mm above the nominal guide stroke. The table here shows the stroke/cylinder range that can be used depending on the nominal stroke of the guide.

Cylinder stroke [mm]	Guide stroke [mm]
0÷75	50
75÷125	100
125÷175	150
175÷225	200
225÷275	250
275÷345	320
345÷425	400
425÷525	500

**ORDERING CODES GDH (BRONZE GUIDE BUSHING)**

Code	Type	Bore
W0700162...	UNIT MW DH 016	16
W0700202...	UNIT MW DH 020	20
W0700252...	UNIT MW DH 025	25

... = Complete the code by adding the stroke in mm.

**ORDERING CODES GDM (BALL GUIDE BUSHING)**

Code	Type	Bore
W0700163...	UNIT MW DM 016	16
W0700203...	UNIT MW DM 020	20
W0700253...	UNIT MW DM 025	25

... = Complete the code by adding the stroke in mm.



**DIMENSIONS OF TYPE GDS**

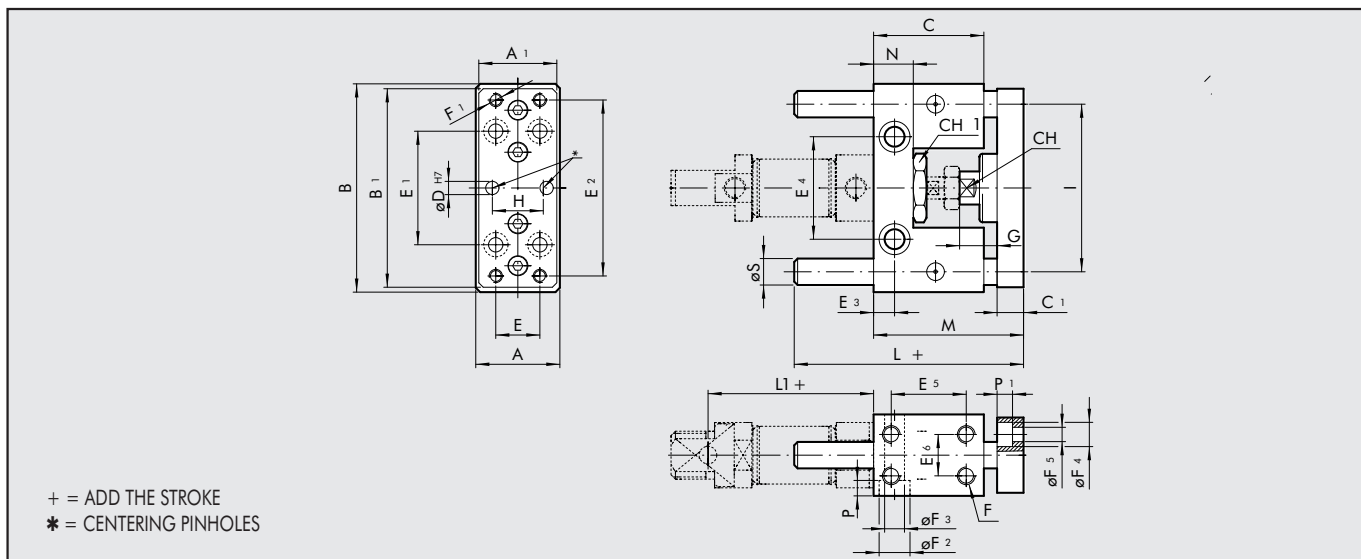

Ø	A	A <sub>1</sub>	B	B <sub>1</sub>	C	C <sub>1</sub>	Ch	Ch <sub>1</sub>	D	E	E <sub>1</sub>	E <sub>2</sub>	E <sub>3</sub>	E <sub>4</sub>	E <sub>5</sub>	E <sub>6</sub>	F	F <sub>1</sub>	F <sub>2</sub>	F <sub>3</sub>	F <sub>4</sub>	F <sub>5</sub>	G	H	I	L	L <sub>1</sub>	M	N	P	P <sub>1</sub>	S
16	30	27	65	63	38	10	8	19	4	15	32	54	6.5	24	25	22	M4	M4	8.5	5.1	7.5	4.5	15	15	46	70	60	54	13	5.5	4.5	10

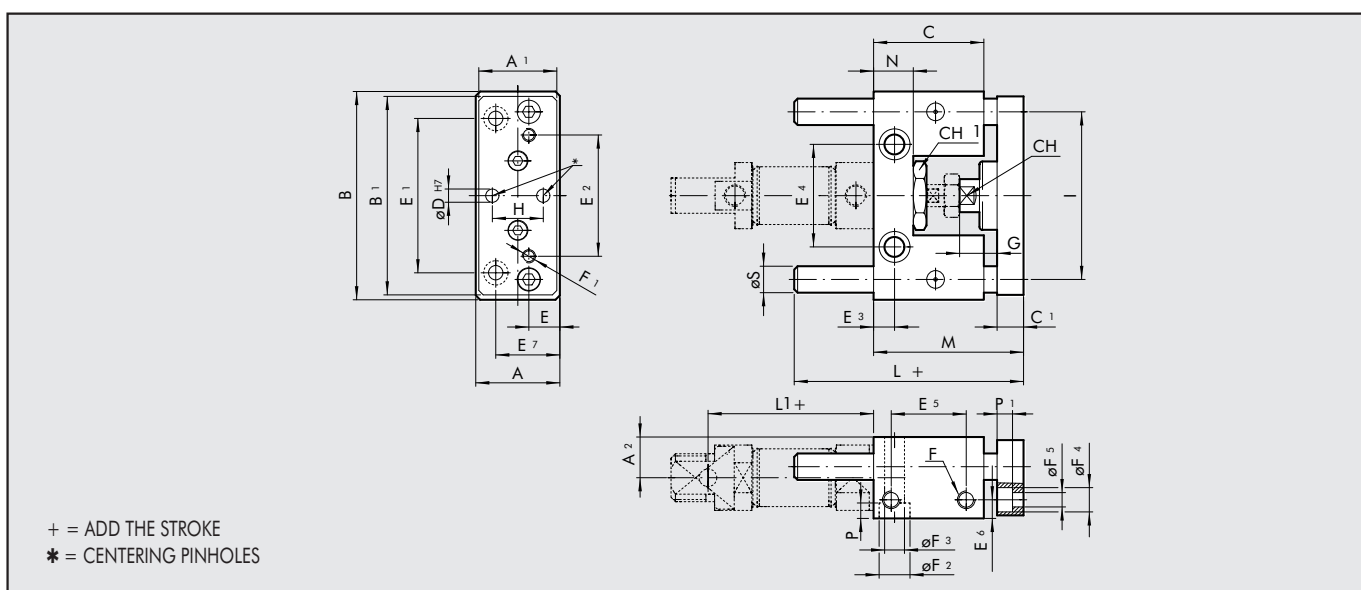

Ø	A	A <sub>1</sub>	A <sub>2</sub>	B	B <sub>1</sub>	C	C <sub>1</sub>	Ch	Ch <sub>1</sub>	D	E	E <sub>1</sub>	E <sub>2</sub>	E <sub>3</sub>	E <sub>4</sub>	E <sub>5</sub>	E <sub>6</sub>	E <sub>7</sub>	F	F <sub>1</sub>	F <sub>2</sub>	F <sub>3</sub>	F <sub>4</sub>	F <sub>5</sub>	G	H	I	L	L <sub>1</sub>	M	N	P	P <sub>1</sub>	S
20	40	38	24	100	90	48	12	13	27	6	15	70	55	8.5	46.5	32	10	30	M8	M6	14	9	11	6.5	22	20	76	77	71	65	17	9	6.5	12
25	40	38	24	100	90	48	12	13	27	6	15	70	55	8.5	46.5	32	10	30	M8	M6	14	9	11	6.5	22	20	76	77	76	71	17	9	6.5	12

**Note:**

Thanks to the dimensional features, it is possible to use the range of strokes - cylinders, as shown in the table here, without the guide piston rods projecting beyond the cylinder fixing value (L1 +).

Cylinder stroke [mm]	Guide stroke [mm]
0 ÷ 50	50
51 ÷ 100	100
101 ÷ 150	150
151 ÷ 200	200
201 ÷ 250	250

**ORDERING CODES GDS (BRONZE GUIDE BUSHING)**

Code	Type	Bore
W0700161...	MW DS 016	16
W0700201...	MW DS 020	20
W0700251...	MW DS 025	25

... = Complete the code by adding the stroke in mm.

## FORCES GENERATED DURING THRUST AND TRACTION (THEORETICAL)

Cylinder bore D mm	Piston rod diameter d mm	Motion	Useful area cm <sup>2</sup>	Thrust and traction force in daN depending on the operating pressure in bar									
				1 bar	2 bar	3 bar	4 bar	5 bar	6 bar	7 bar	8 bar	9 bar	10 bar
16	6	thrust	2.01	2.0	4.0	6.0	8.0	10.1	12.1	14.1	16.1	18.1	20.1
		traction	1.73	1.7	3.5	5.2	6.9	8.6	10.4	12.1	13.8	15.6	17.3
20	8	thrust	3.14	3.1	6.3	9.4	12.6	15.7	18.8	22.0	25.1	28.3	31.4
		traction	2.64	2.6	5.3	7.9	10.6	13.2	15.8	18.5	21.1	23.8	26.4
25	10	thrust	4.91	4.9	9.8	14.7	19.6	24.5	29.5	34.4	39.3	44.2	49.1
		traction	4.12	4.1	8.2	12.4	16.5	20.6	24.7	28.9	33.0	37.1	41.2

## WEIGHT OF CYLINDERS

Cylinder "ISO 6432" Series TP

Ø	Single-rod		Through-rod	
	Weight [g] Stroke=0	Weight [g] each mm	Weight [g] Stroke=0	Weight [g] each mm
16	66	0.377	101	0.604
20	94	0.628	131	1.03
25	144	0.908	207	1.536

## NOTES