

PNEUMO-POWER

Supplies 24V electric power via an M8 connector. Compressed air to power the generator can be supplied merely by connecting a pipe to the 1/8" threaded port. To interrupt energy production, all you have to do is to switch off the compressed air supply by means of a cock or solenoid valve.

Voltage remains constant irrespective of changes in input pressure or the load applied (within the limits specified in the catalogue).

An easy-to-read light display shows the status of the appliance at all times.



TECHNICAL DATA		50-1	50-2	50-3
Maximum power at 7 bar	W	3	7.5	12
Nominal voltage supplied		24 VDC		
Voltage tolerance		±3%		
Ripple and Noise		including line regulation, load regulation and factory setup mMax 250 mV p-p o 79 mV rms		
Rise time at 7 bar at max. load	sec	Measured at 20Mhz bandwidth by using a pair-wire terminated with a 0.1µF and 47µF load capacitor		
		2.5	1.5	1
Hold time at 7 bar at 50% of load	sec	See graph page 5		
		1.3	0.9	0.8
Electrical connector		See graph page 5		
Overload protection e cortocircuito		M8 - 3 poles		
Overvoltage protection		"Hiccup mode" with automatic recovery upon cessation of overload		
Electromagnetic compatibility		Intervention if output voltage >120% than nominal value		
		In compliance with the following standards:		
		EN 61000-2: Part 6-2: Generic standards - Immunity for industrial environments		
Life at 6.3 bar	h	EN 61000-2: Part 6-3: Generic standards - Emission standard for residential, commercial and light-industrial environments		
Signals		20.000		
		LED diagnostics.		
		Visual signals are flanked by a diagnostic pin on the M8 connector, which closet a GND contact when the voltage is 24 VDC ±3%		
Index of protection for electronic devices		IP 65		
Input fluid		Filter un lubricated air		
Minimum input pressure	bar	4	3	3
Maximum input pressure	bar	7	7	7
Max air consumption at 7 bar (Leq)	NI/min	32	50	75
Air ports		Input: G1/8"		
		Exhaust: G1/8"		
Temperature range	°C	0 ÷ 50		
Max noise level at 7 bar		75 dB		
Casing material		Painted aluminium		
Assembly position		Any		
Fixing		Using 3 M4x10 screws		
Weight	gr	The device can be stabilised using rubber vibration dampers forniti in dotazione		
		330		

LED DIAGNOSTICS OVERVIEW

LED off or red LED flashing	Temporarily on start-up: the output voltage has not yet reached 24V If this condition persists, the applied load is probably excessive with respect to the input pressure.
Green LED fixed	Normal operation: the output voltage has reached 24V Optimal use of the compressed air supply.
Green LED flashing	Normal operation: the output voltage has reached 24V but the generator is used below capacity (can supply more power at the same compressed air supply)
Red and Green LED flashing	Charge short-circuited: output voltage is automatically cut off. It will return within the tolerance range upon elimination of overload.
Red LED fixed	The maximum supply pressure has been exceeded and the device risks getting damaged.

COMPONENTS

- ① Aluminium body, treated and painted
- ② Aluminium body, treated and painted
- ③ Aluminium base, treated and painted
- ④ Brass nozzle
- ⑤ Turbine and electrical generator unit
- ⑥ M8 3-pin connector
- ⑦ NBR gaskets
- ⑧ Electronic board
- ⑨ Vibration dampers
- ⑩ Silencer

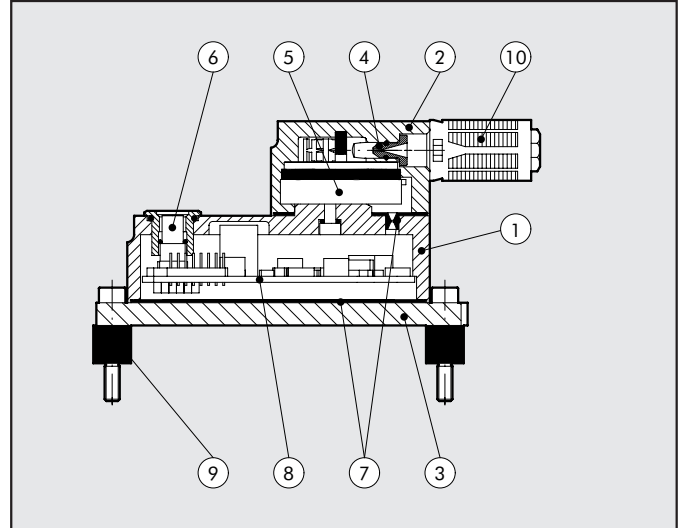

FUNCTION DIAGRAM

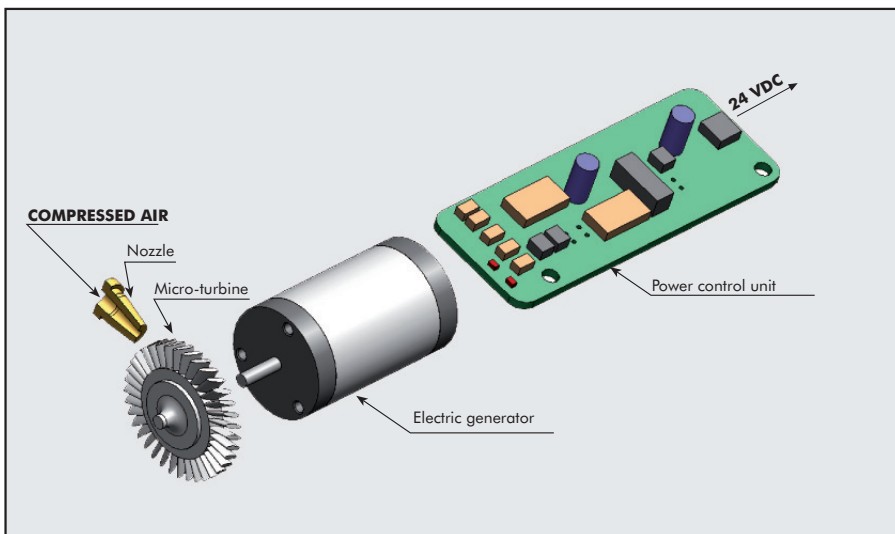

The compressed air is supplied via a nozzle that converts pressure energy into kinetic energy. The supersonic jet of air strikes the blades of a micro-turbine, which is integral with an electrical generator. An electronic power management unit ensures constant voltage output at varying input pressures and applied electrical loads. The electrical power thus generated can supply any type of utility.

FIXING

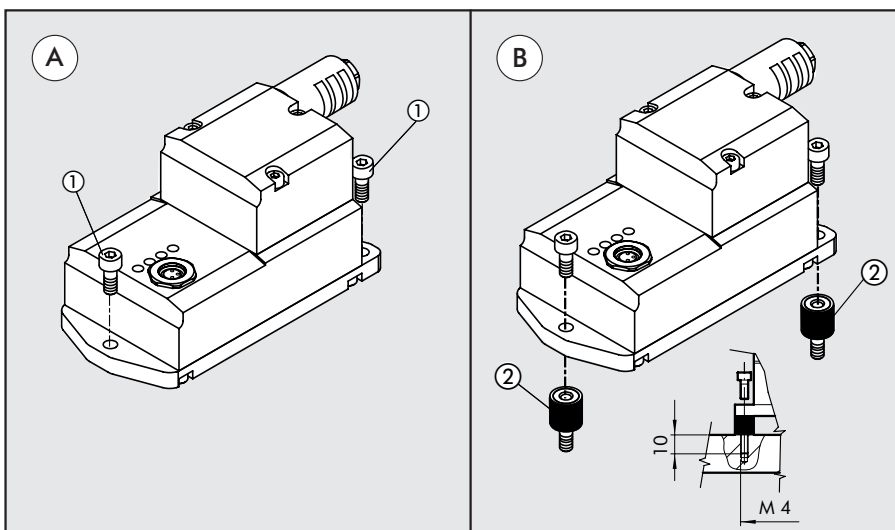

The generator can be fixed on a flat surface using the 3 M4x10 screws ① (fig. A), and the 3 vibration dampers ② supplied with the device (fig. B).

PRESSURE / AVAILABLE POWER

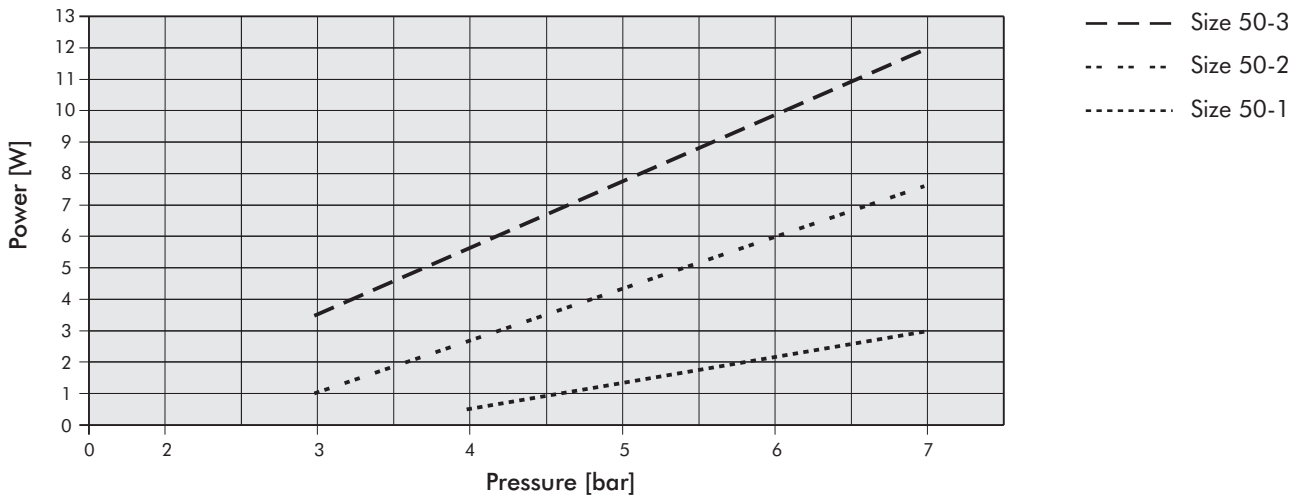

Important: if the input pressure is not sufficient to generate the power required by the electric load, the generator keeps switching on and off (intermittently). You only need to increase the air pressure (as shown in the chart) to get the required power.

AVAILABLE AIR / POWER CONSUMPTION

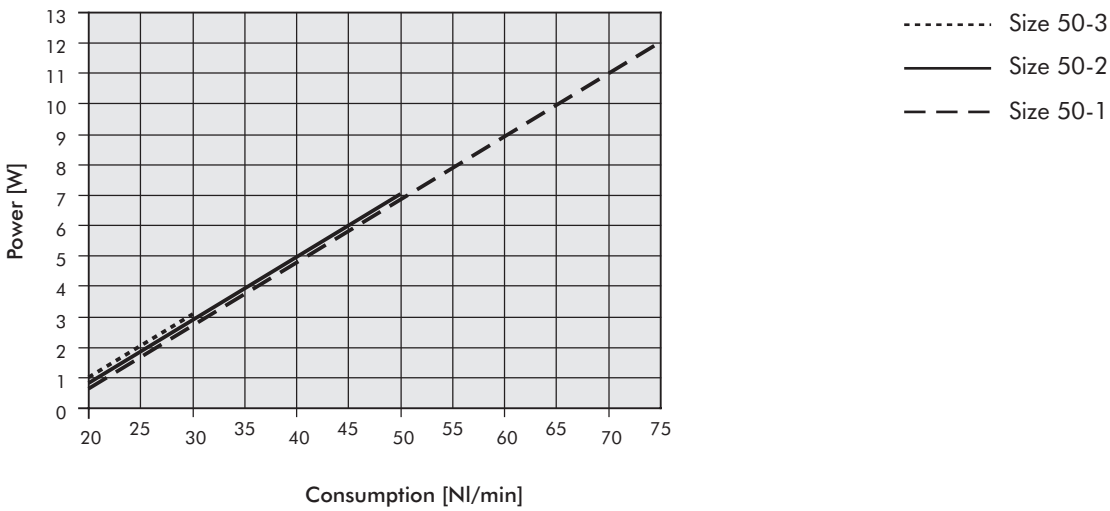

PRESSURE / AIR CONSUMPTION

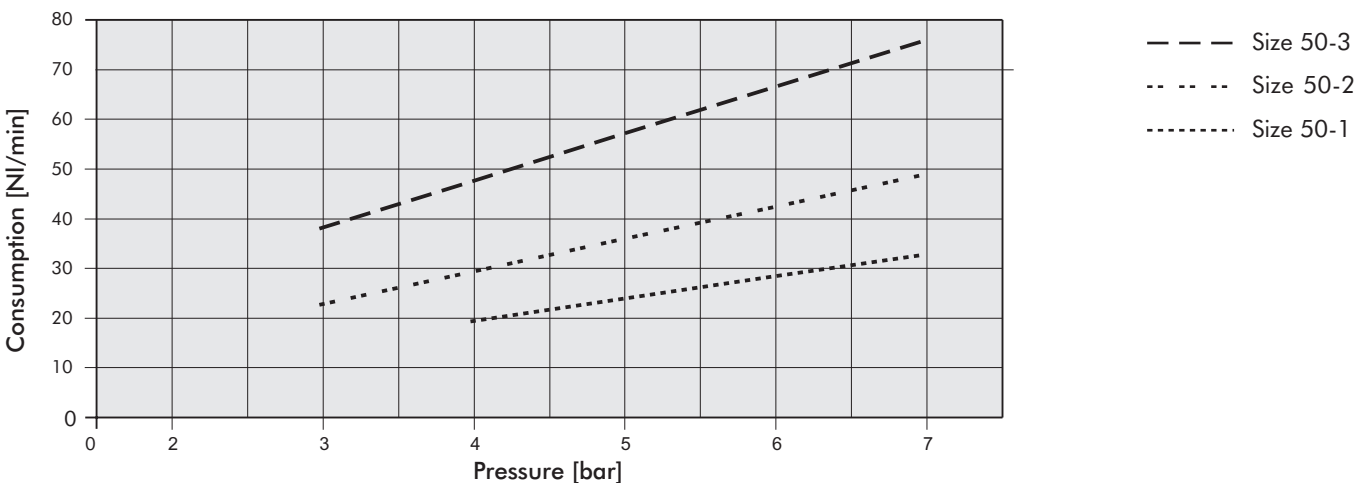

PRESSURE AND ACTUATION TIME WITH ELECTRICAL LOAD

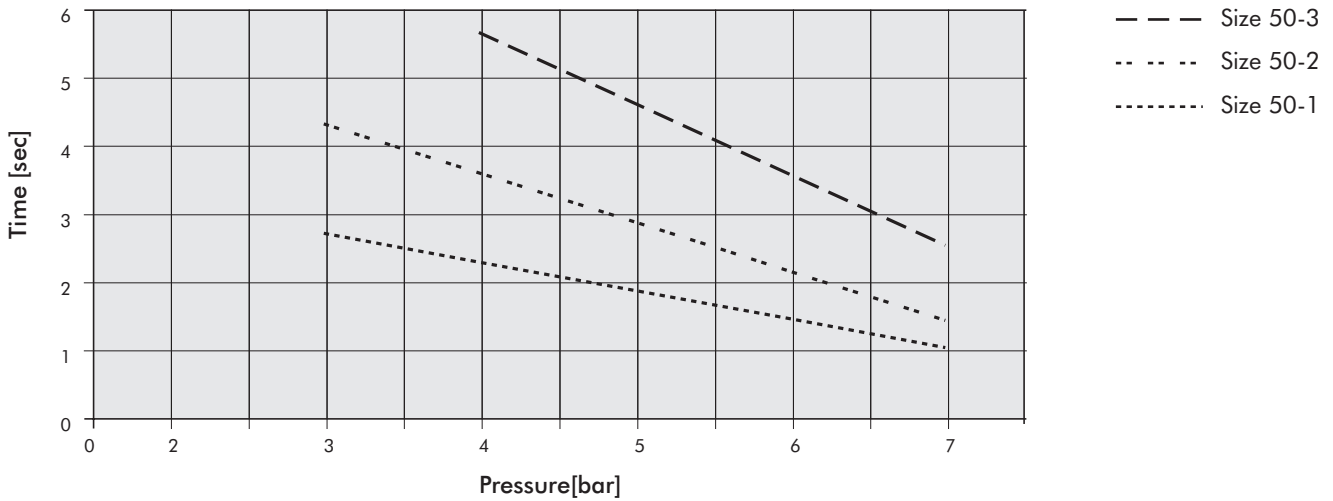

The above graph shows, for a set input pressure, the maximum time required to reach the rated output voltage (with maximum electrical load applicable for this pressure) as the size of the device changes. For example, with a size 50-2 device having an input pressure of 5.2 bar, a 24VDC output voltage will be available about two seconds after start-up.

RISE TIME AND HOLD TIME GRAPH

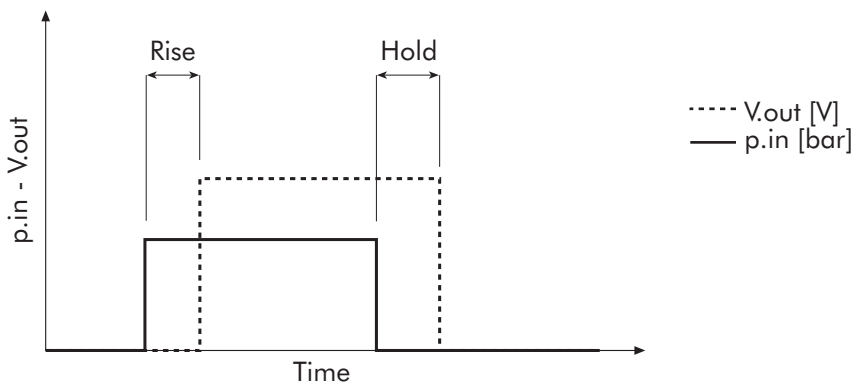

Rise time: the delay from activation of the compressed air supply to 24V power supply to the M8 connector.

Hold time: the time for which 24V is maintained after the compressed air supply has been switched off.

NOTES

DIMENSIONS

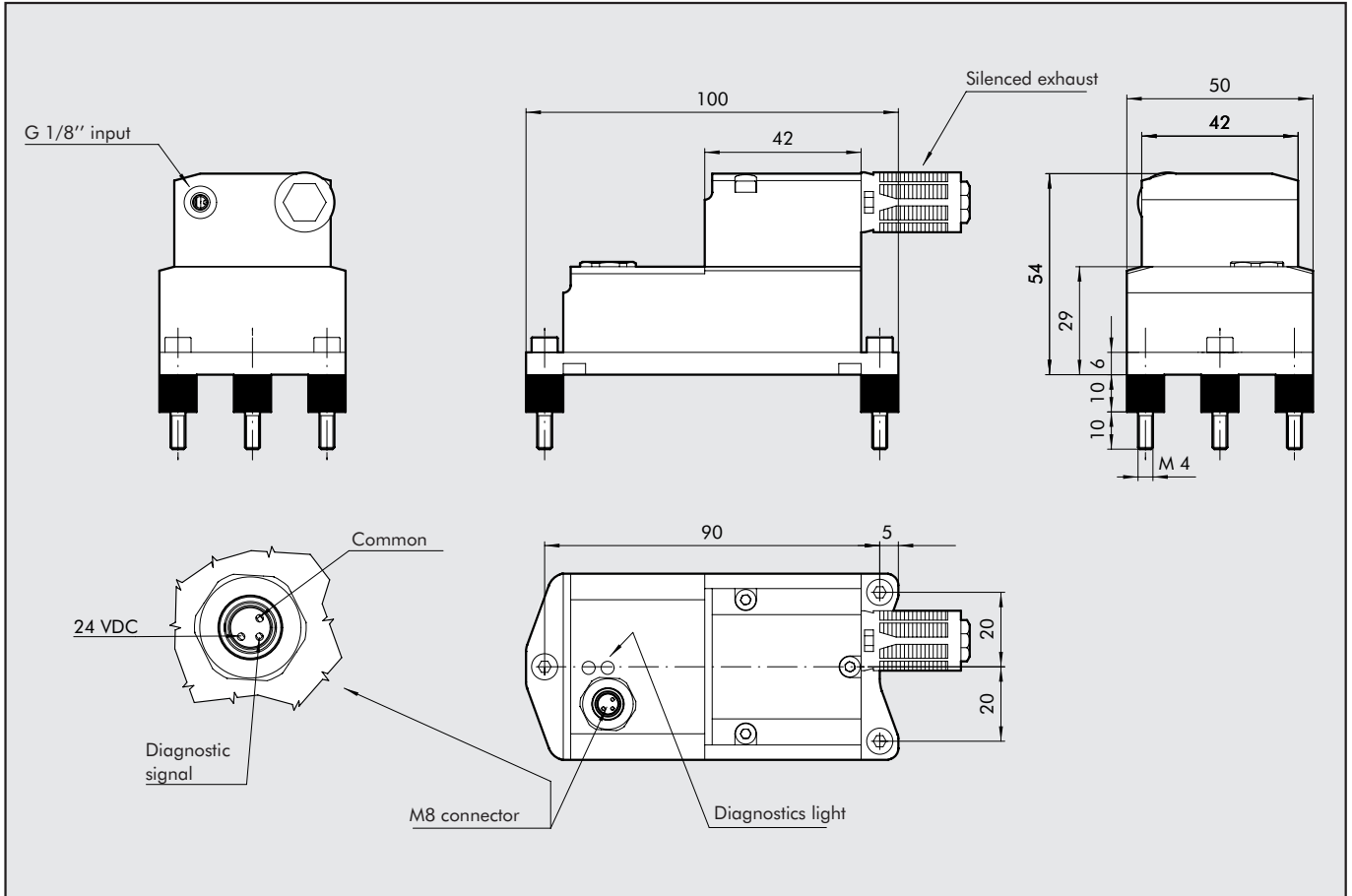

ORDERING CODES

Code	Description
0251530000	PNEUMO POWER 50-1 3 W 24 VDC
0251550000	PNEUMO POWER 50-2 7,5 W 24 VDC
0251570000	PNEUMO POWER 50-3 12 W 24 VDC

ACCESSORIES

M8 CONNECTOR WITH CABLE

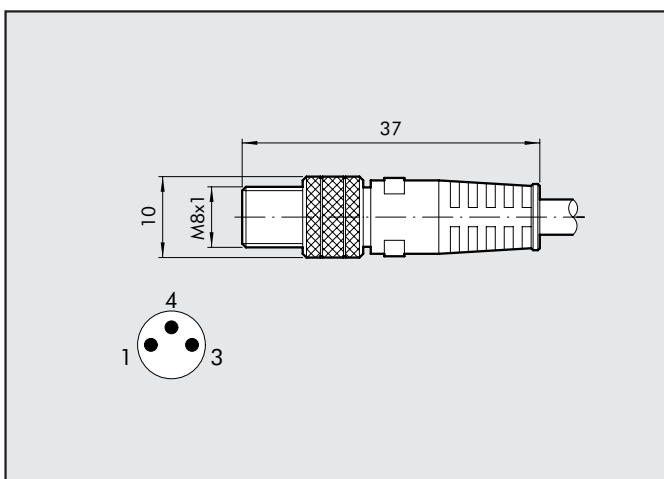

Code	Description
0240009053	M8 male 3-pin connector with 2.5 metres of cable

Pin	Wire colour	
1	brown	+24V
3	blue	GND
4	black	diagnostics