

BASES FOR "PLT-10" MULTIPLE CONNECTION

Series PLT-10 solenoid valves can be mounted on bases complete with electrical and pneumatic connections, from 4 to 24 positions. The electric contacts of each valve are linked to a single multiple connector via a printed circuit board. The connector has 9 pins or 25 pins, depending on the model and the number of valves that can be mounted. Versions with 25-pin connectors can interface with standard field buses by means of Profibus-DP, Interbus-S, Can-Open and Device-Net modules for Multimach.

The compressed-air supply is common to all the valves and can be provided on either side of the base by means of a 1/8" fitting. Connection to the utilities is via automatic integrated cartridges for Ø4 pipe. The solenoid valve outlet is free, in a slot in the base. The bases can be secured from above using M3 screws, or on a DIN bar using a bracket (see accessories).

The bases can mount various types of PLT-10 solenoid valves: 3/2 NC, 3/2 NO, with or without a manual actuator. With this modular system, you can select the desired sequence of valves (NC, NO, blind) and change it at any time.

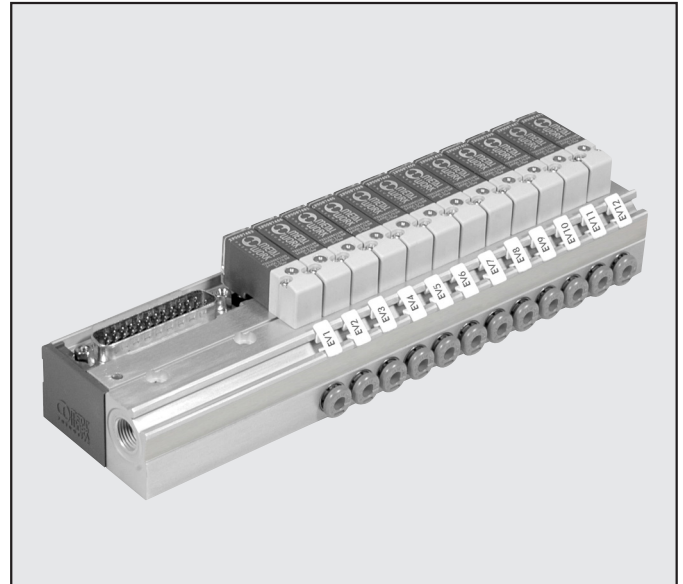

TECHNICAL DATA

Supply voltage	24 VDC
Max input	0.7W per position for PLT-10 STD without LED 0.9W per position for PLT-10 STD with LED 3W/0.3W per position for PLT-10 with Speed-up
Valve actuation indicator	Led mounted on the PLT-10 (on versions of solenoid valve where envisaged)
Operating temperature range °C	5 ÷ 50
Protection degree (with valves and connectors mounted)	IP 40
Maximum number of mountable PLT-10s	24
Number of contacts	9, of which 1 common, for versions with 4 and 8 positions 25, of which 1 common, for versions with 4, 8, 12, 16, 20, 24 positions

COMPONENTS

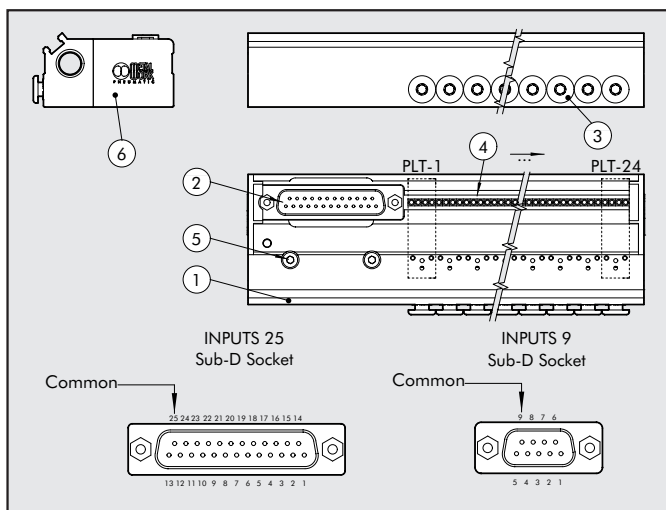

- ① Anodized aluminium base
- ② Multi-pin electrical connector
- ③ Automatic integrated cartridges for Ø4 pipe
- ④ Electrical connectors for PLT-10 solenoid valves mounted on printed circuit board
- ⑤ Securing screw
- ⑥ Technopolymer cover

CONNECTION DIAGRAM

25 PIN		9 PIN	
Position of electrical contact	Nr. PLT	Position of electrical contact	Nr. PLT
1	PLT1	1	PLT1
2	PLT2	2	PLT2
3	PLT3	3	PLT3
4	PLT4	4	PLT4
5	PLT5	5	PLT5
6	PLT6	6	PLT6
7	PLT7	7	PLT7
8	PLT8	8	PLT8
9	PLT9	9	COMMON (-)
10	PLT10		
11	PLT11		
12	PLT12		
13	PLT13		
14	PLT14		
15	PLT15		
16	PLT16		
17	PLT17		
18	PLT18		
19	PLT19		
20	PLT20		
21	PLT21		
22	PLT22		
23	PLT23		
24	PLT24		
25	COMMON (-)		

Pilot numbering from left to right, starting from the position closest to the connection.



ASSEMBLY OF SOLENOID VALVES AND ACCESSORIES

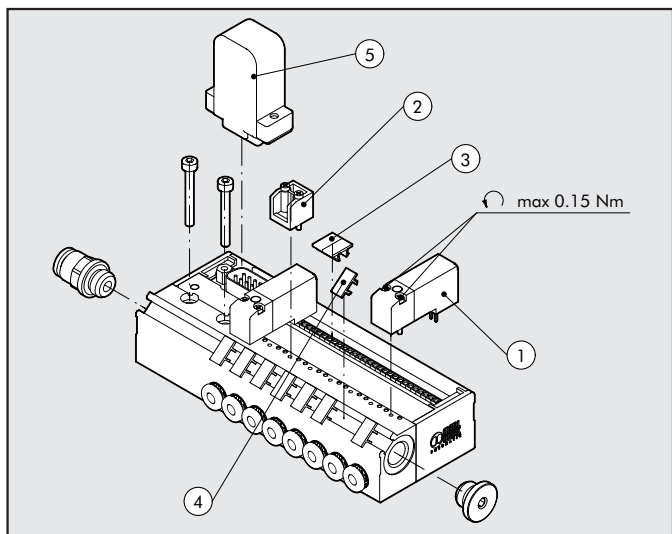

- ① Solenoid valve
- ② Pneumatic circuit cap for blind position
- ③ Electric circuit cap for blind position (use two identification labels)
- ④ Identification label
- ⑤ Electrical connector

HOW TO SECURE THE BASE

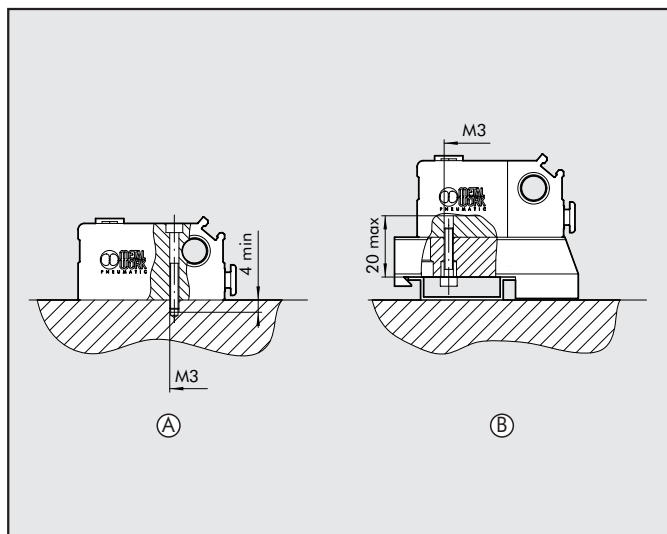

- Ⓐ From above using M3 screws
- Ⓑ On a DIN bar, using the bracket and screws provided
The bases come with the rear holes plugged by provided dowels.

CODES AND DIMENSIONS FOR BASES 9 AND 25 PINS

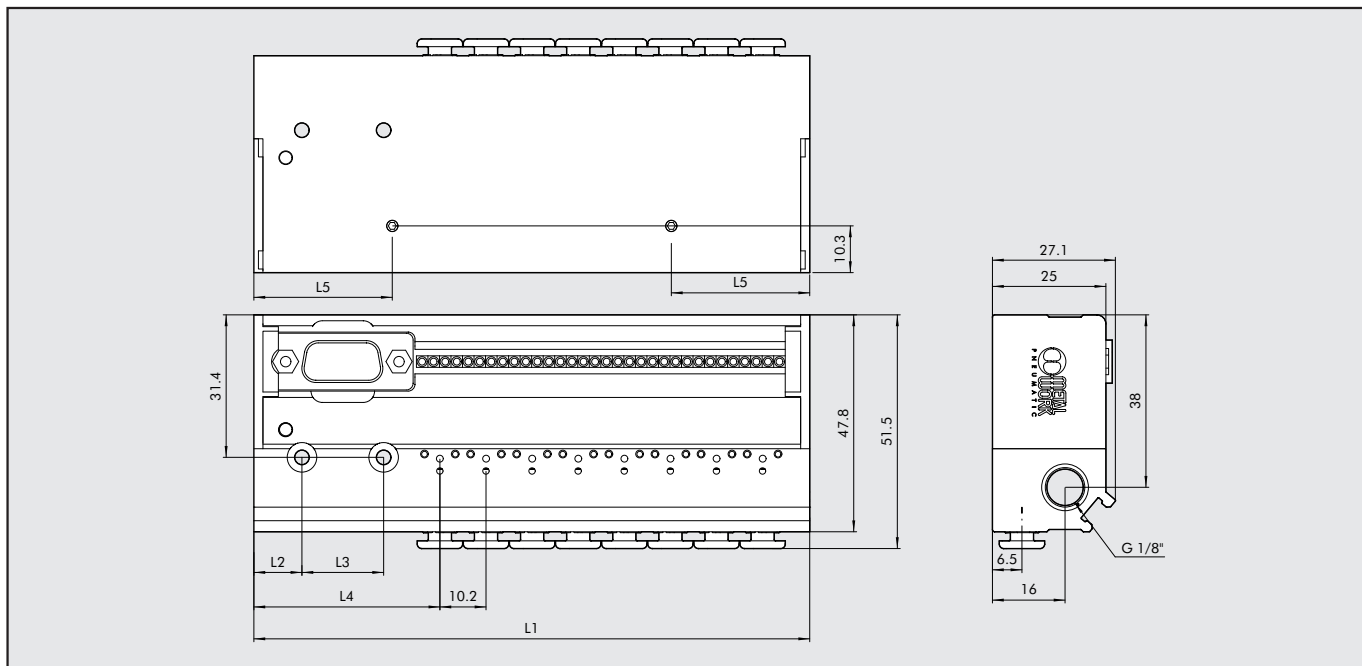

Code	Description	No. of PINS	No. of positions	L ₁	L ₂	L ₃	L ₄	L ₅	Weight [g]
0210040004	4-POSN. BASE PLT 10 9-PIN MULT CONN.	9	4	81.9	10.6	18	41	19.6	160
0210040008	8-POSN. BASE PLT 10 9-PIN MULT CONN.	9	8	122.5	10.6	18	41	19.6	235
0210240004	4-POSN. BASE PLT 10 25-PIN MULT CONN.	25	4	104.8	15.5	30	63.9	30.5	210
0210240008	8-POSN. BASE PLT 10 25-PIN MULT CONN.	25	8	145.4	15.5	30	63.9	30.5	280
0210240012	12-POSN. BASE PLT 10 25-PIN MULT CONN.	25	12	186	15.5	30	63.9	30.5	355
0210240016	16-POSN. BASE PLT 10 25-PIN MULT CONN.	25	16	226.6	15.5	30	63.9	30.5	430
0210240020	20-POSN. BASE PLT 10 25-PIN MULT CONN.	25	20	267.2	15.5	30	63.9	30.5	500
0210240024	24-POSN. BASE PLT 10 25-PIN MULT CONN.	25	24	307.8	15.5	30	63.9	30.5	575

PLT-10 FOR MULTIPLE ELECTRIC CONNECTION

TECHNICAL DATA		NC	NO
Type		3/2 NC ed NO	
Operating temperature range	T _e	5° ÷ 50° C	
Fluid temperature	T _g	5° ÷ 50° C	
Fluid		Filtered, lubricated or unlubricated air	
Operating life		Over 50 million cycles	
Weight	g	12	
Voltage tolerance	ΔV	± 10 %	
Max operating frequency	f	30 Hz	
Switching factor	ED	100 %	
Insulation class		F155	
Degree of protection		IP 51	IP 50
Power connection		PLUG IN	PIN

OPERATING CHART

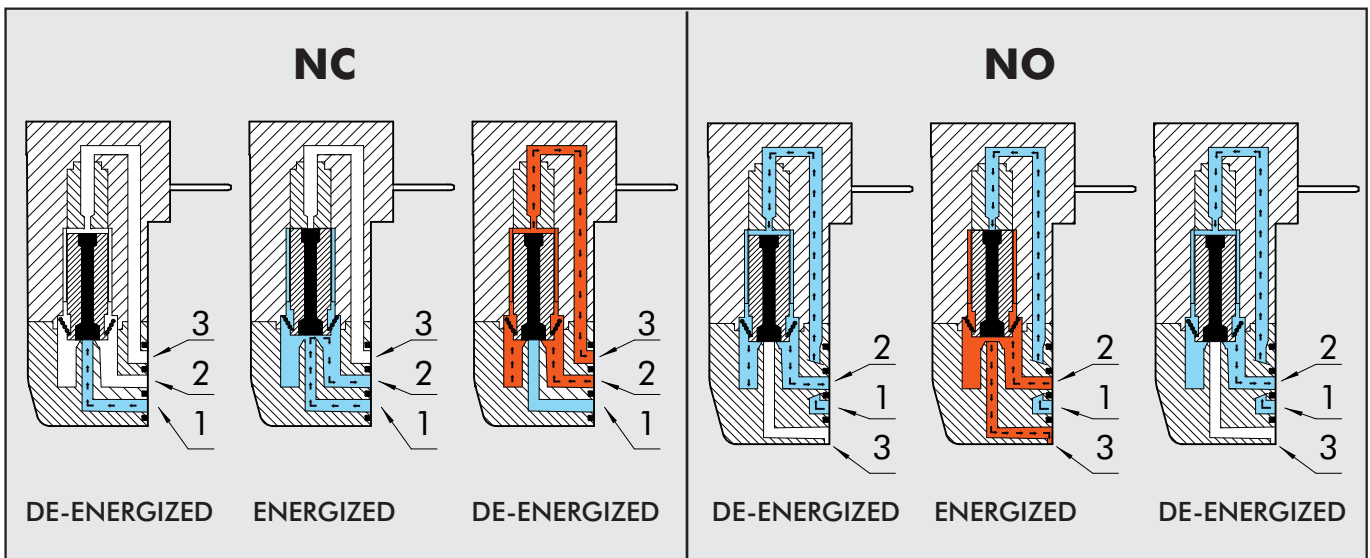

COMPONENTS

- ① Transparent cover: PA612-transparent
- ② Assembly screws: galvanized steel
- ③ PIN
- ④ Mobile core over-stamping: FKM/FPM
- ⑤ Mobile core: AISI 403F
- ⑥ Coil over-stamping: PA66
- ⑦ Body-coil gasket: NBR70
- ⑧ Assembly screws: galvanized steel
- ⑨ Body gasket: NBR
- ⑩ Body: PA66
- ⑪ Manual gasket: NBR (only for version with manual operated)
- ⑫ Manual control: OT58 nickel-plated brass (only for version with manual operated)
- ⑬ Manual spring: AISI 302 (only for version with manual operated)
- ⑭ Spring: AISI 302
- ⑮ Winding: PPS - Copper wire
- ⑯ Fixed core: AISI 430F
- ⑰ Coil-cover gasket: NBR
- ⑱ Electronic board (only for version with electronic board)

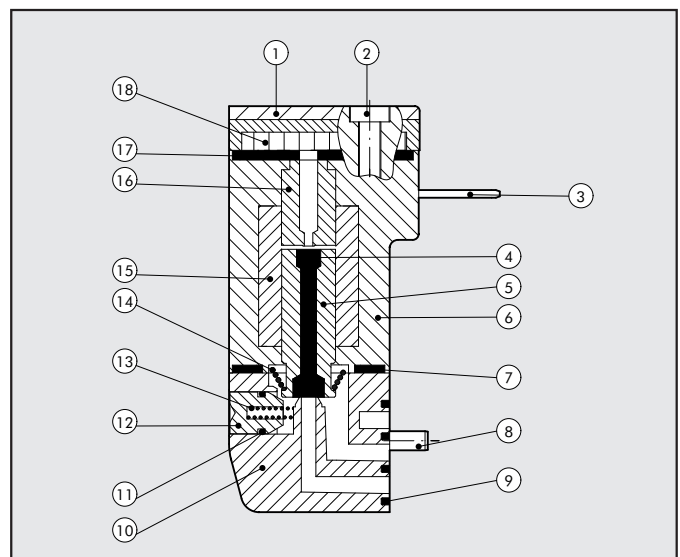

ACCESSORIES

CONNECTION BRACKETS ON DIN BAR

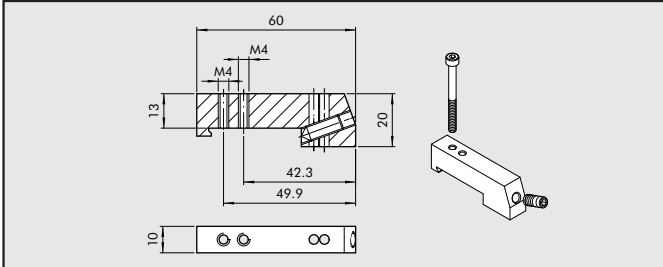

Code	Description	Weight [g]
0227301600	CONNECTION BRACKETS ON DIN BAR HDM/CM	30

Supplied complete with one M4x45 screws and one M6 grub screw
Individually packed

CAP FOR UNUSED POSITION

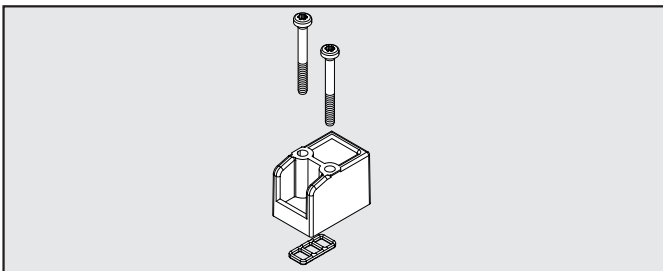

Code	Description	Weight [g]
W0400100200	ACC. CAP 10 mm	6

STRAIGHT AND 90° CONNECTOR KIT, 9 WIRES

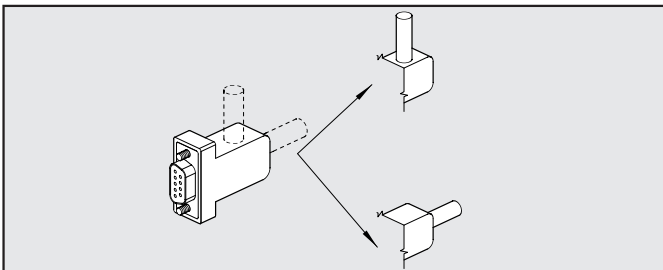

Code	Description	Weight [g]
0226180102	STRAIGHT AND 90° CONNECTOR KIT, 9 WIRES	31

STRAIGHT AND 90° CONNECTOR KIT, 25 WIRES

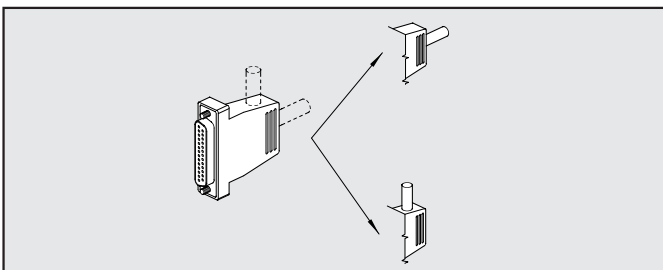

Code	Description	Weight [g]
0226180101	STRAIGHT AND 90° CONNECTOR KIT, 25 WIRES	48

CABLES

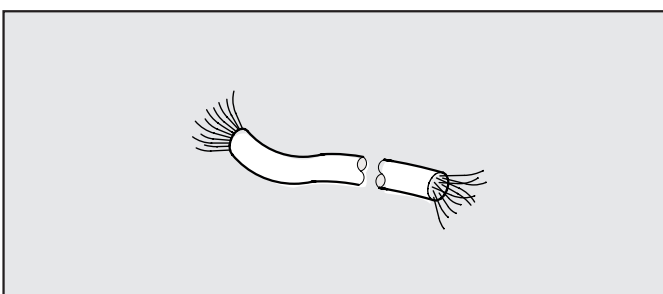

Code	Description	Weight [g]
0226107201	10-WIRE CABLE	86
0226107101	19-WIRE CABLE	122
0226107102	25-WIRE CABLE	130

Specify the number of metres desired



STRAIGHT PRE-WIRED CONNECTOR KIT

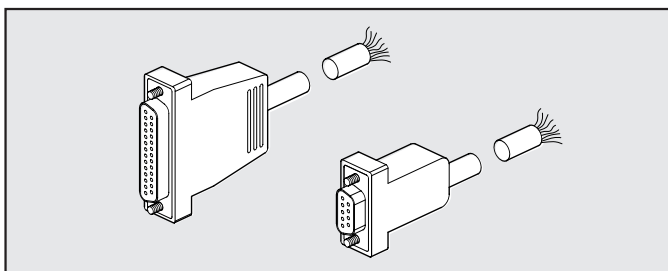

Code	Description	Weight [g]
0226900100	CONNECTOR + 9-WIRE AXIAL CABLE L.=1 M	90
0226900250	CONNECTOR + 9-WIRE AXIAL CABLE L.=2.5 M	220
0226900500	CONNECTOR + 9-WIRE AXIAL CABLE L.=5 M	434
0226920100	CONNECTOR + 25-WIRE AXIAL CABLE L.=1 M	132
0226920250	CONNECTOR + 25-WIRE AXIAL CABLE L.=2.5 M	320
0226920500	CONNECTOR + 25-WIRE AXIAL CABLE L.=5 M	636

PRE-WIRED 90° CONNECTOR

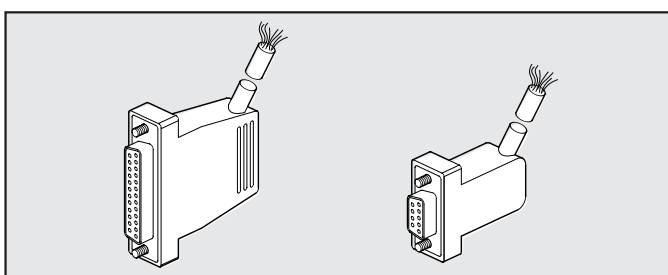

Code	Description	Weight [g]
0226910100	CONNECTOR + 9-WIRE 90° CABLE L.=1 M	90
0226910250	CONNECTOR + 9-WIRE 90° CABLE L.=2.5 M	220
0226910500	CONNECTOR + 9-WIRE 90° CABLE L.=5 M	434
0226930100	CONNECTOR + 25-WIRE 90° CABLE L.=1 M	132
0226930250	CONNECTOR + 25-WIRE 90° CABLE L.=2.5 M	320
0226930500	CONNECTOR + 25-WIRE 90° CABLE L.=5 M	636

WIRING DIAGRAM FOR PRE-WIRED PLUG CONNECTORS

25 PIN	Position of electrical contact	Colour of the corresponding wire	Position of electrical contact	Colour of the corresponding wire	Position of electrical contact	Colour of the corresponding wire	9 PIN	Position of electrical contact	Colour of the corresponding wire
	1	blue/black	10	brown/white	19	yellow/black		1	green/black
2	red/brown	11	red/orange	20	white	2	white		
3	white/black	12	light blue	21	blue/white	3	blue/black		
4	red/blue	13	yellow/white	22	brown	4	blue		
5	black/orange	14	yellow	23	green/white	5	yellow/black		
6	yellow/red	15	red/green	24	red	6	yellow		
7	black/brown	16	orange	25	green/black	7	red/black		
8	white/red	17	orange/white			8	green		
9	red/black	18	green			9	white/black		

IDENTIFICATION PLATE KIT

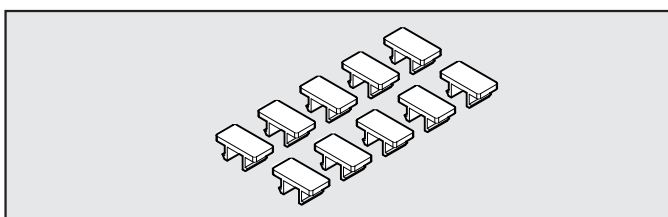

Code	Description
0226107000	IDENTIFICATION PLATE KIT
Comes in 10-pc. packs	

R17 - PIPE RELEASE SPANNER

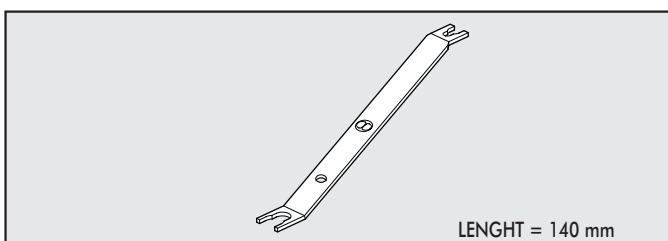

Code	Description	Ø Tube	Notes
2L17001	RL17	from Ø 3 to Ø 10	For R fitting and Fox fitting