

PRECISION SLIDES SERIES S13

Series S13 precision slides feature a dual-acting pneumatic cylinder that has the sole purpose of pushing and pulling the load, a ground steel guide that is integral with the body, and a ball recirculation pad that is fixed onto the moving table and is designed to withstand all the loads and movements applied. This ensures accurate movement with virtually no play, and the piston rods do not suffer wear as there are no lateral loads. All the slides are equipped with sensor magnets.

The body can be secured on many sides. The load side can be fixed onto the table from the top or the front. The compressed air supply can be connected on three sides. The retractable sensors can be fitted on the right or on the left. All these possibilities make the application extremely flexible. The width is extremely reduced to allow installation in small spaces and the combination of several reduced-pitch slides.



TECHNICAL DATA					
Pressure range	bar	2 ÷ 8 (0,2 ÷ 0,8 MPa)			
Operating temperature	°C	- 10 to +70			
Fluid		Lubricated and unlubricated compressed air at 20 µm, must be uninterrupted when lubricated			
Minimum and maximum speed	mm/s	30 and 500			
Pneumatic fittings		M5			
Type of guide		Ball recirculation			
Versions		Magnetic dual-acting with rubber buffer			
Bore	mm	Ø 6	Ø10	Ø16	Ø 20
Strokes	mm	10	10	10	10
		25	25	25	25
		---	---	50	50
Theoretical thrust force, at 6 bar	N	17	47	120	188
Theoretical pull force, at 6 bar	N	13	40	104	158
Admitted loads		See diagrams			
Admitted kinetic energy	Joule	0,012	0,025	0,050	0,100
Stroke tolerance	mm	0 / +1,0			
Assembly position		any (horizontal and vertical)			
Weight	Kg	See table			

COMPONENTS

- ① NUT: stainless steel
- ② SNAP RING: galvanised steel
- ③ FRONT BASE: bronze
- ④ BODY: anodized aluminium
- ⑤ GUIDE: tempered stainless steel
- ⑥ PISTON: aluminium
- ⑦ BALL RECIRCULATION PAD: stainless steel
- ⑧ BUFFER: NBR
- ⑨ REAR BASE: anodized aluminium
- ⑩ PLATE: anodized aluminium
- ⑪ PISTON ROD GASKET: type EM, NBR
- ⑫ O-RING: NBR
- ⑬ PISTON ROD: stainless steel
- ⑭ PISTON GASKET: type PZ, NBR
- ⑮ MAGNET: neodymium (Ø6 and Ø10)
plastoferrite (Ø16 and Ø20)

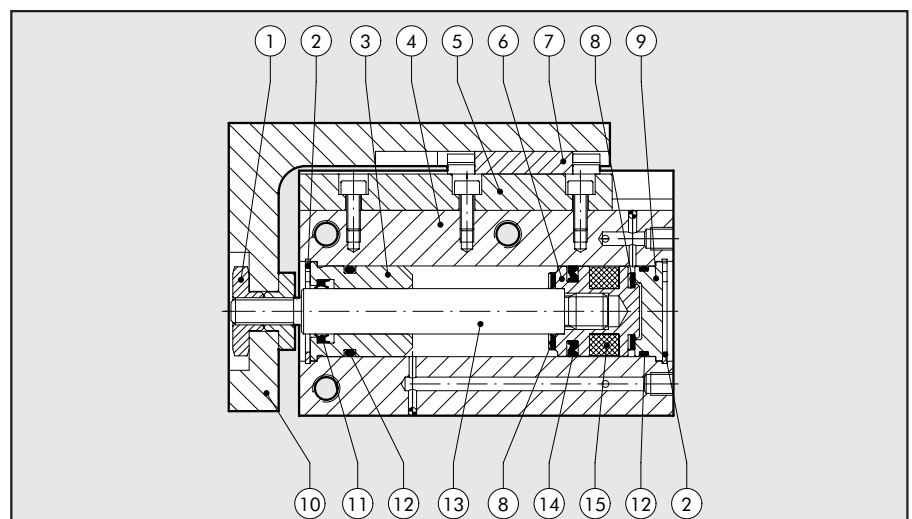

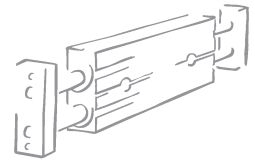

WEIGHT (gr)					WEIGHT OF MOVING PART(gr)				
stroke	bore				stroke	bore			
	6	10	16	20		6	10	16	20
10	68	125	230	455	10	30	50	100	180
25	90	160	280	550	25	40	68	125	220
50	---	---	350	660	50	---	---	167	290

MASS/VELOCITY DIAGRAM

M (kg) = Mass applied
 L (mm) = Distance between the axis of the piston rod and the barycentre of the mass
 v (mm/s) = Velocity of the slide
 vert = Limit with vertical movement

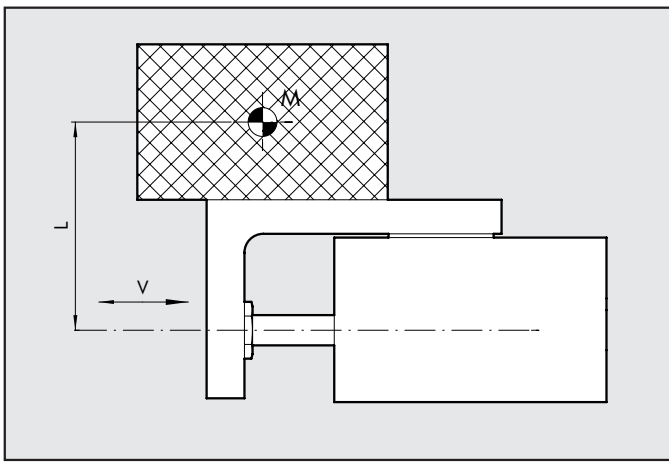

ADMITTED LOADS DIAGRAM

S13-6

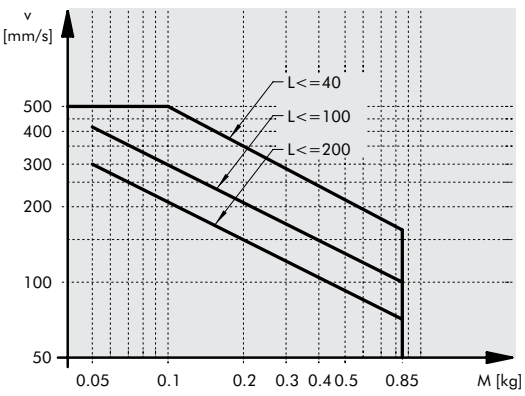

S13-10

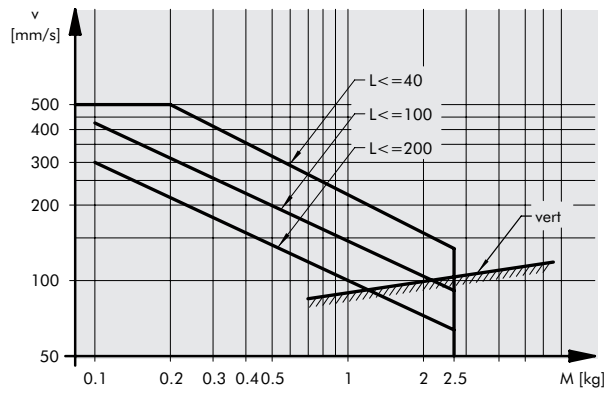

S13-16

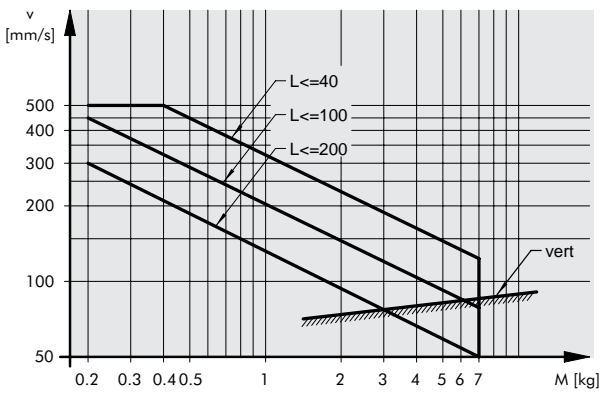

S13-20

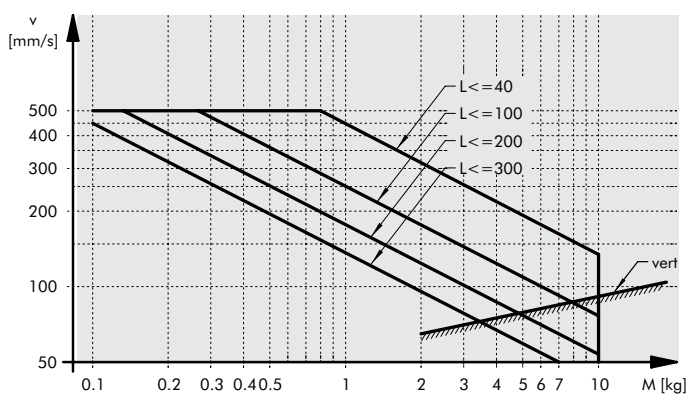

FIXING OPTIONS

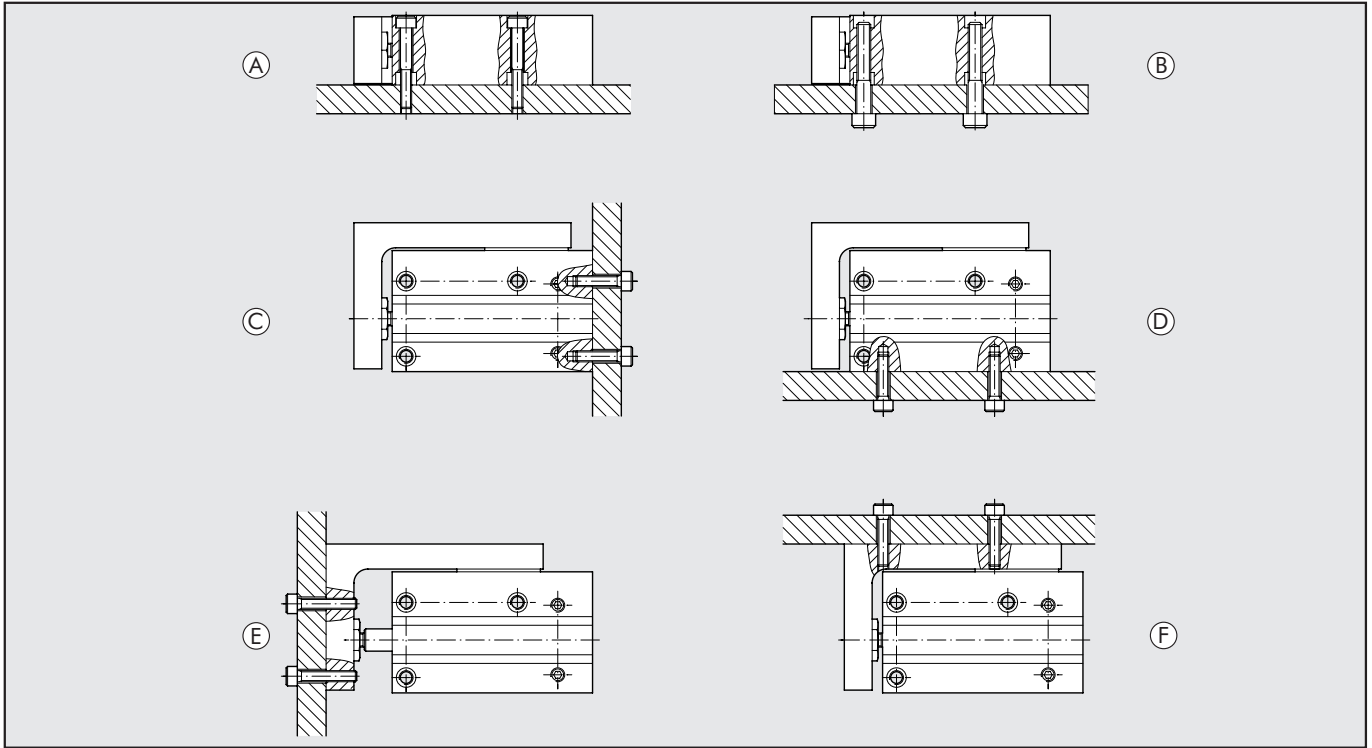

FIXING THE BODY:

- (A) Lateral, via the through holes.
- (B) Lateral, on the hole threads.
- (C) Rear, on the threaded holes.
- (D) Vertical, on the threaded holes.

FIXING THE MOVING TABLE:

- (E) Front, on the threaded holes.
- (F) Top, on the threaded holes.

N.B. Since the table is supported by a ball guide/pad, avoid applying excessive torques or forces. When securing the screws, hold the table, not the body, so that the torque discharges through the ball pad.

COMPRESSED-AIR SUPPLY

The compressed air supply can be from the back, from the left or from the right. The slide comes with holes on the left and right that are plugged with screws and O-ring seals. If you wish to use the holes, remove the screws and O-rings and fix them in the holes in the back, applying a drop of adhesive to the screw thread.

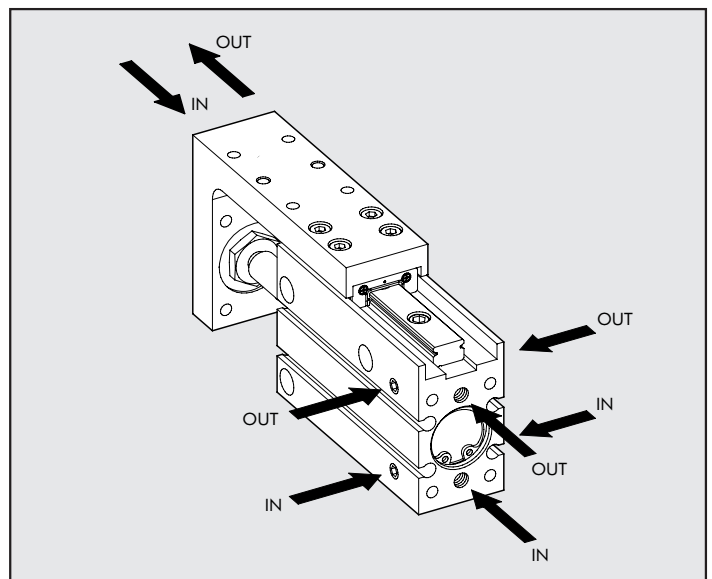

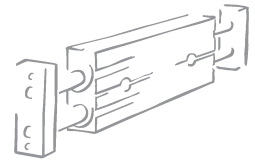

DIMENSIONS

1

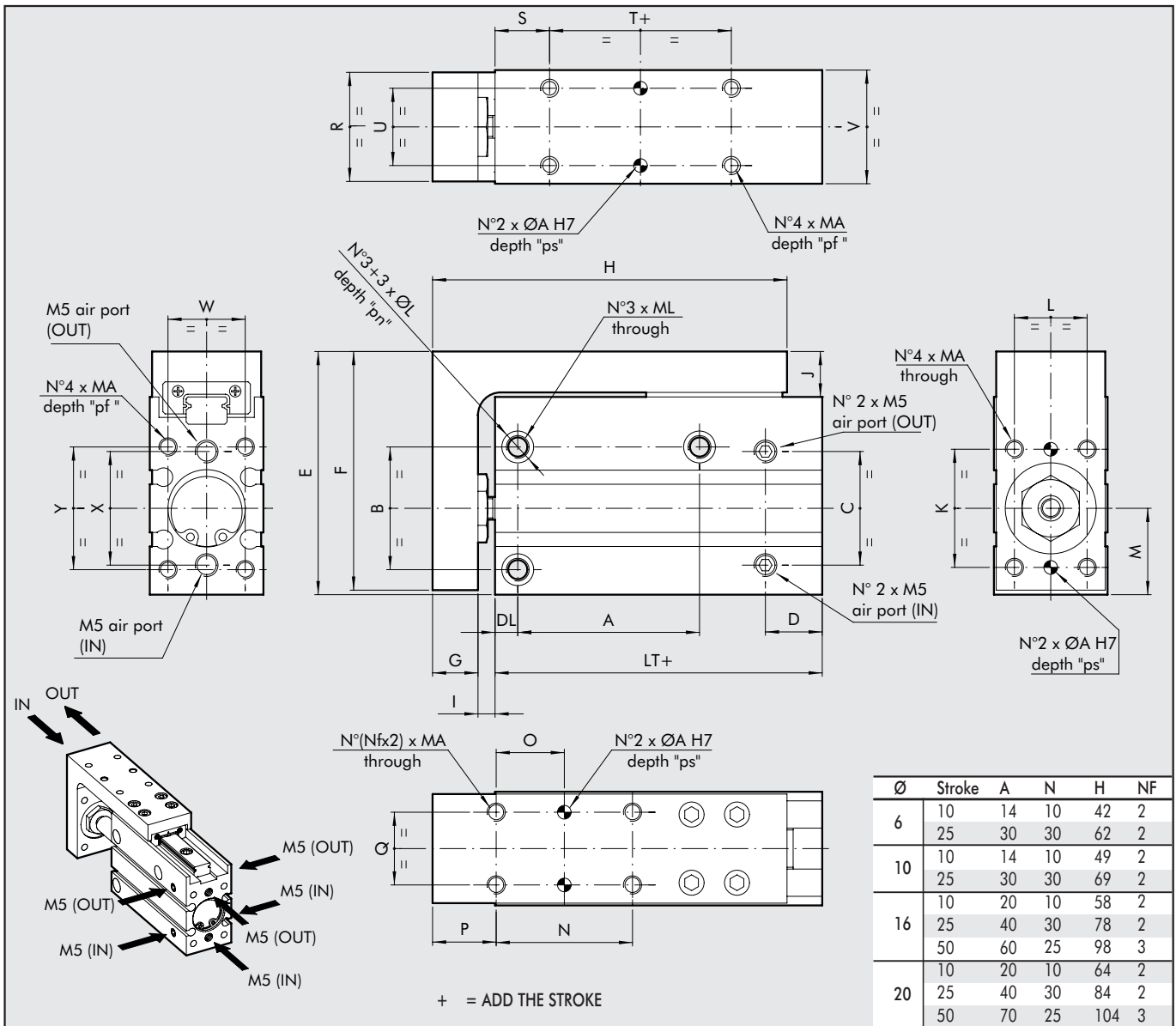

Code	Ø	LT	B	C	D	E	F	G	I	J	K	MA	pf	ØA	ps	L	M	O	P	Q	R	S
W1471063...*	6	31	19	18	10	39	38	5.5	2.9	7.5	15	M3	5	2	4.5	9	14.5	N/2	8	9	15	10
W1471103...*	10	35	23	20	12.5	47	46	7.5	4	9	18	M4	6	2	4.5	11	15.5	N/2	11	11	19	12
W1471163...	16	42	27	25	12.5	53.5	52.5	10	3.75	10	26	M4	7	3	7.5	16	19	N/2	14	16	24	12
W1471203...*	20	52.5	34	32	15	64.5	63.5	11	4.5	10.5	34	M5	9	3	7.5	20	23	N/2	14	20	31	15

*Enter the stroke in mm (e.g. Ø6 stroke 10=W1471063010)

T	U	V	W	X	Y	ØL	pn	ML	DL
5	9	16	10.5	18	19	6	3.5	M4	4
5	13	20	13	20	23	7.5	4.5	M5	5
10	17	25	17	25	27	7.5	4.5	M5	5
10	20	32	20	32	34	9.5	7.5	M6	6

Standard strokes:

Bore Ø6	->	10; 25 mm
Bore Ø10	->	10; 25 mm
Bore Ø16	->	10; 25; 50 mm
Bore Ø20	->	10; 25; 50 mm

