

# COMPACT PRECISION SLIDES SERIES S8

There are two sliding systems available:

- Type SB-B with in-line ball bearings
- Type S8-C with ball re-circulation bearings

The guides fixed onto the slide body are made of hardened and tempered steel. There are slots in the body of slide S8-C for mounting a retracting sensor. There are also kits for mounting adjustable mechanical stops or hydraulic shock absorbers.

All S8 slides come on request with permanent pneumatic cushioning.

Slide made with Toss-System.

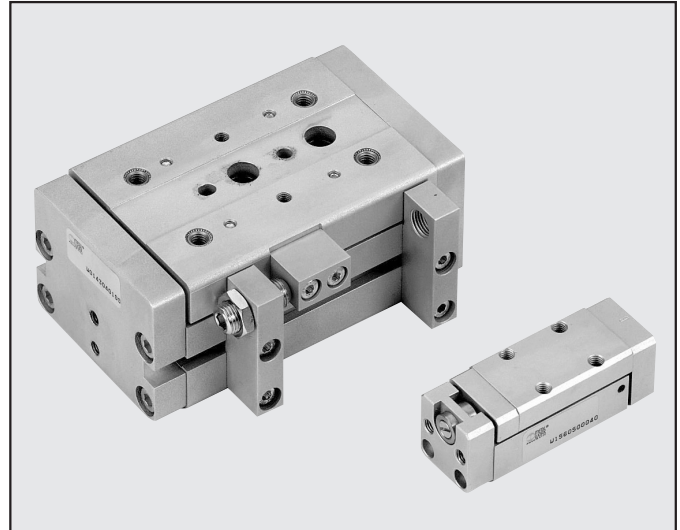

TECHNICAL DATA		S8-B	S8-C
Pressure range	bar		2-6
Temperature range	°C		-10 to +60
Fluid		20µ unlubricated filtered air. Lubrication, if used, must be continuous	
Bores	mm	10-16-20-25-32	20-25-32
Strokes	mm	10; 25; 50; 80; 100; 125; 160; 200	25; 50; 80; 100; 125; 160; 200
Type of guide		In-line ball bearings (bars of hardened, tempered and ground steel)	Ball re-circulation (bars of hardened, tempered and ground steel)
Air ports		Both on front plate	
Versions		Double-acting With permanent pneumatic cushioning	Double-acting With permanent pneumatic cushioning With 5 mm adjustable mechanical stops With hydraulic shock absorbers With pneumatic cushioning and mechanical stops
End-of-stroke sensors		Magnetic, only on request	Magnetic, retracting type

## COMPONENTS FOR SERIES S8-B

- ① SLIDE BODY: aluminium
- ② GUIDES: high Cr alloy steel
- ③ IN-LINE BALL CAGE: steel
- ④ MOVING PART: aluminium
- ⑤ FRONT PLATE: aluminium
- ⑥ PISTON ROD: thick chromium plated steel
- ⑦ BASE: Hostaform®
- ⑧ PISTON: NBR
- ⑨ AIR PORT PLATE: aluminium
- ⑩ STATIC O-RINGS: NBR
- ⑪ CUSHIONING CONE: OT 58

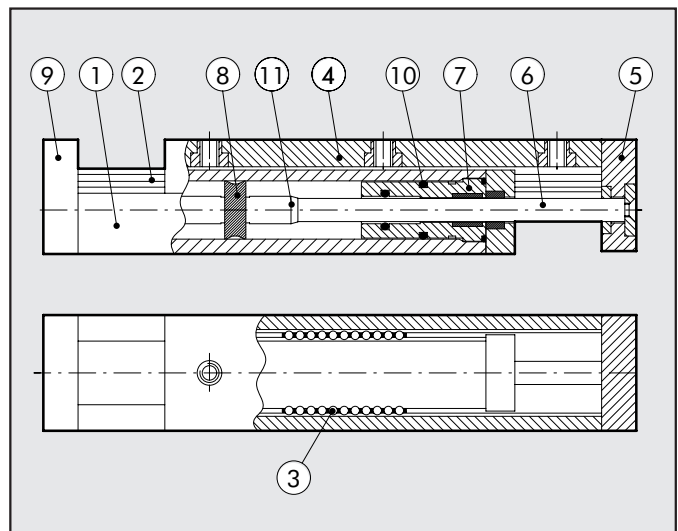

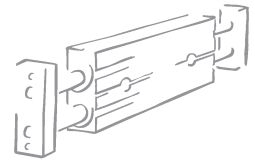

**COMPONENTS FOR SERIES S8-C**

- ① SLIDE BODY: aluminium
- ② GUIDES: high Cr alloy steel
- ③ BALL RE-CIRCULATION TRACKS: steel
- ④ MOVING PART: aluminium
- ⑤ FRONT PLATE: aluminium
- ⑥ PISTON ROD: thick chromium plated steel
- ⑦ BASE: Hostaform®
- ⑧ PISTON: NBR
- ⑨ AIR PORT PLATE: aluminium
- ⑩ STATIC O-RINGS: NBR
- ⑪ CUSHIONING CONE: OT 58
- ⑫ MAGNET: Plastoferrite

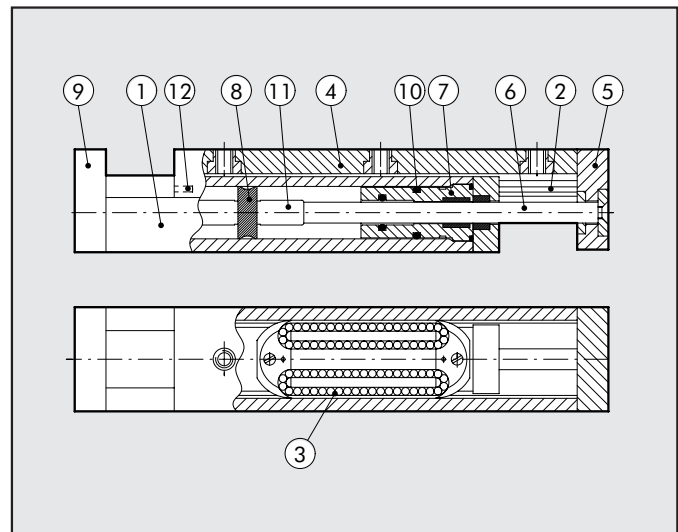

**COMPACT PRECISION SLIDE SERIES S8-B**

- ① Pneumatic port for slide opening
- ② Pneumatic port for slide closing
- ③ Ball system guide

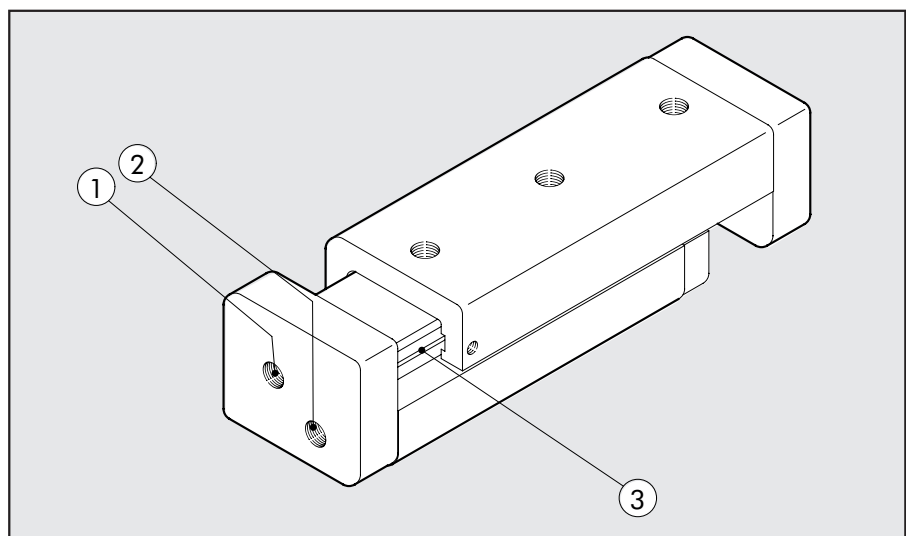

**COMPACT PRECISION SLIDE SERIES S8-C**

- ① Pneumatic port for slide opening
- ② Pneumatic port for slide closing
- ③ Slot cover strip
- ④ Retracting sensor
- ⑤ Hydraulic decelerator
- ⑥ Mechanical stop
- ⑦ Sensor slot
- ⑧ Lubrication point for ball re-circulation system
- ⑨ Ball system guide
- ⑩ Magnet
- ⑪ Hydraulic decelerator/mechanical stop support
- ⑫ Counter block for hydraulic decelerator/mechanical stop

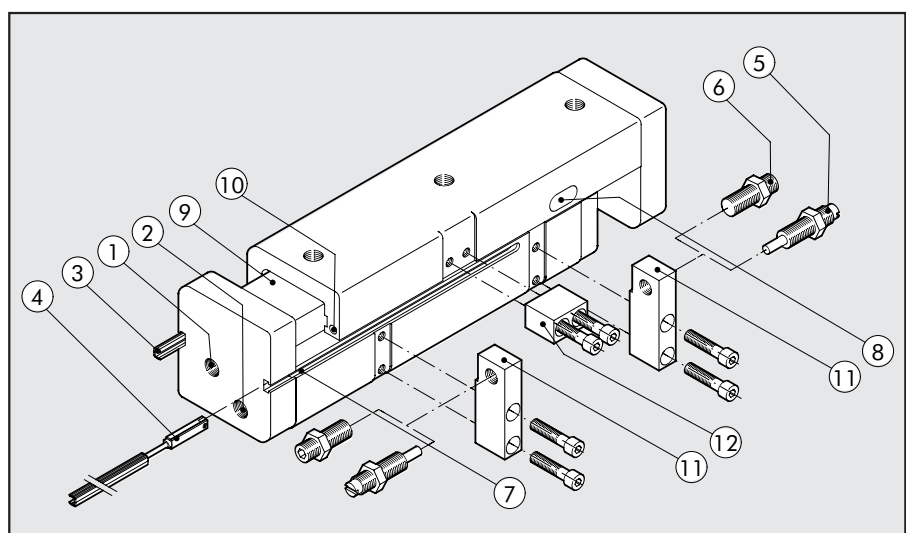

**CALCULATIONS FOR COMPACT PRECISION SLIDES SERIES S8-B**

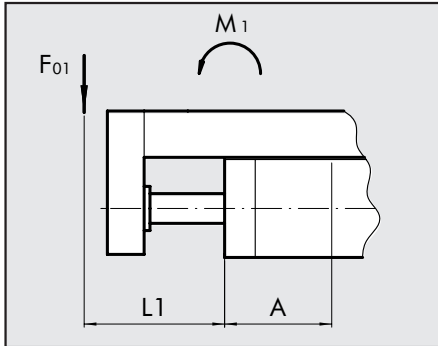

$$F_{01} (L_1 + A) \leq M_1$$

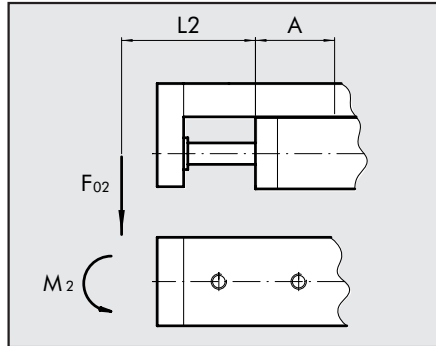

$$F_{02} (L_2 + A) \leq M_2$$

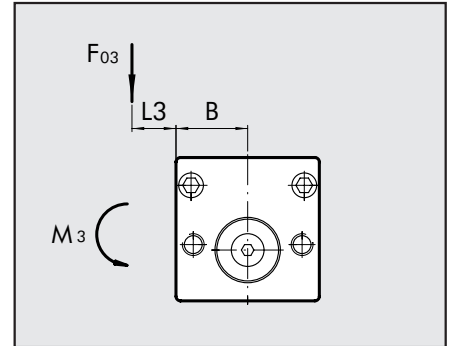

$$F_{03} (L_3 + B) \leq M_3$$

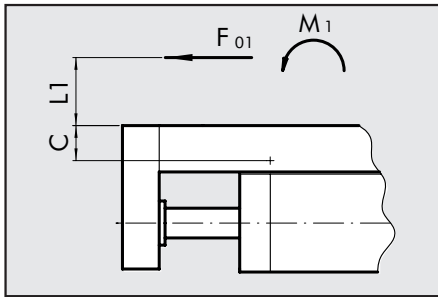

$$F_{01} (L_1 + C) \leq M_1$$

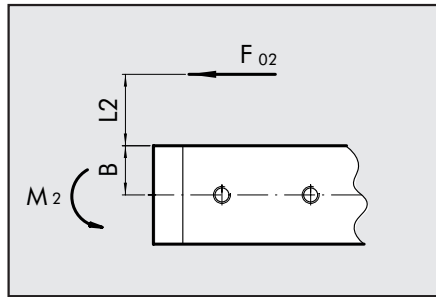

$$F_{02} (L_2 + B) \leq M_2$$

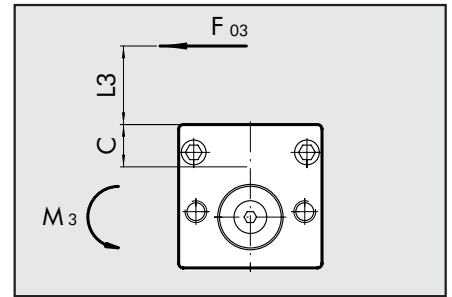

$$F_{03} (L_3 + C) \leq M_3$$

**SERIES S8-B**

Ø	STROKE 10 mm					STROKE 25 mm					STROKE 50 mm					STROKE 80 mm				
	M1/M2 Nm	M3 Nm	A mm	B mm	C mm	M1/M2 Nm	M3 Nm	A mm	B mm	C mm	M1/M2 Nm	M3 Nm	A mm	B mm	C mm	M1/M2 Nm	M3 Nm	A mm	B mm	C mm
10-B	1.37	1.04	40.6	17.25	10.4	1.42	1.04	48.1	17.25	10.4	2.12	1.45	66.9	17.25	10.4	2.6	1.76	86.1	17.25	10.4
16-B	1.52	1.15	40.6	19.75	11.5	1.58	1.15	48.1	19.75	11.5	2.35	1.61	66.9	19.75	11.5	2.88	1.96	86.1	19.75	11.5
20-B	1.67	1.27	40.6	19.75	13.6	1.74	1.27	48.1	19.75	13.6	2.58	1.77	66.9	19.75	13.6	3.17	2.16	86.1	19.75	13.6
25-B	3.32	2.65	49.2	27.25	16	3.83	2.65	56.7	27.25	16	4.86	4.16	77	27.25	16	6.7	5.68	102.4	27.25	16
32-B	4.6	3.87	49.7	32.25	17.7	4.78	4.56	57.2	32.25	17.7	6.36	5.88	75.8	32.25	17.7	9.31	8.48	103.2	32.25	17.7

Ø	STROKE 100 mm					STROKE 125 mm					STROKE 160 mm					STROKE 200 mm				
	M1/M2 Nm	M3 Nm	A mm	B mm	C mm	M1/M2 Nm	M3 Nm	A mm	B mm	C mm	M1/M2 Nm	M3 Nm	A mm	B mm	C mm	M1/M2 Nm	M3 Nm	A mm	B mm	C mm
10-B	3.23	2.18	98.4	17.25	10.4	3.93	2.18	121.2	17.25	10.4	5.22	2.18	151.3	17.25	10.4	6.13	2.18	178.1	17.25	10.4
16-B	3.59	2.42	98.4	19.75	11.5	4.37	2.42	121.2	19.75	11.5	5.8	2.42	151.3	19.75	11.5	6.81	2.42	178.1	19.75	11.5
20-B	3.95	2.67	98.4	19.75	13.6	4.8	2.67	121.2	19.75	13.6	6.38	2.67	151.3	19.75	13.6	7.5	2.67	178.1	19.75	13.6
25-B	8.07	6.82	120.2	27.25	16	13	6.82	140.5	27.25	16	11.38	6.82	168.4	27.25	16	13.71	6.82	201.4	27.25	16
32-B	10.84	9.75	119.4	32.25	17.7	13.07	9.75	141.2	32.25	17.7	14.78	9.75	164.9	32.25	17.7	18.48	9.75	200.4	32.25	17.7

**EXAMPLE OF CALCULATION**

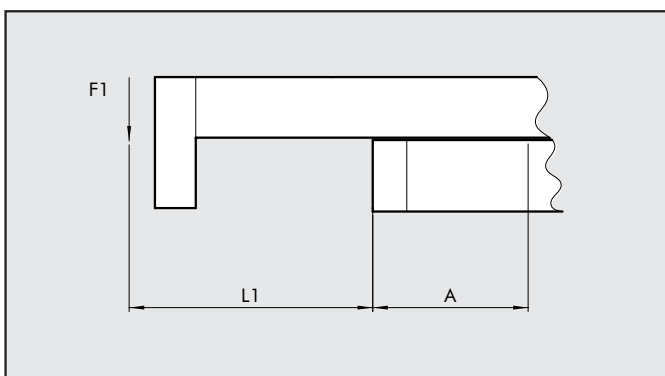

Values: Ø25 corsa 80 mm Tipo S8-B  
 DISTANCE  $L_1 = 40 \text{ mm} = 0.04 \text{ m}$   
 LONG MOMENT  $M_1 = 6.7 \text{ Nm}$   
 CORRECTION FACTOR  $A = 102.4 \text{ mm} = 0.1024 \text{ m}$

$$\text{CALCULATION: } F_1 \leq \frac{M_1}{L_1 + A} = \frac{6.7 \text{ Nm}}{0.04 + 0.1024} = 47 \text{ N}$$



**DIMENSIONS OF COMPACT PRECISION SLIDES SERIES S8-B**

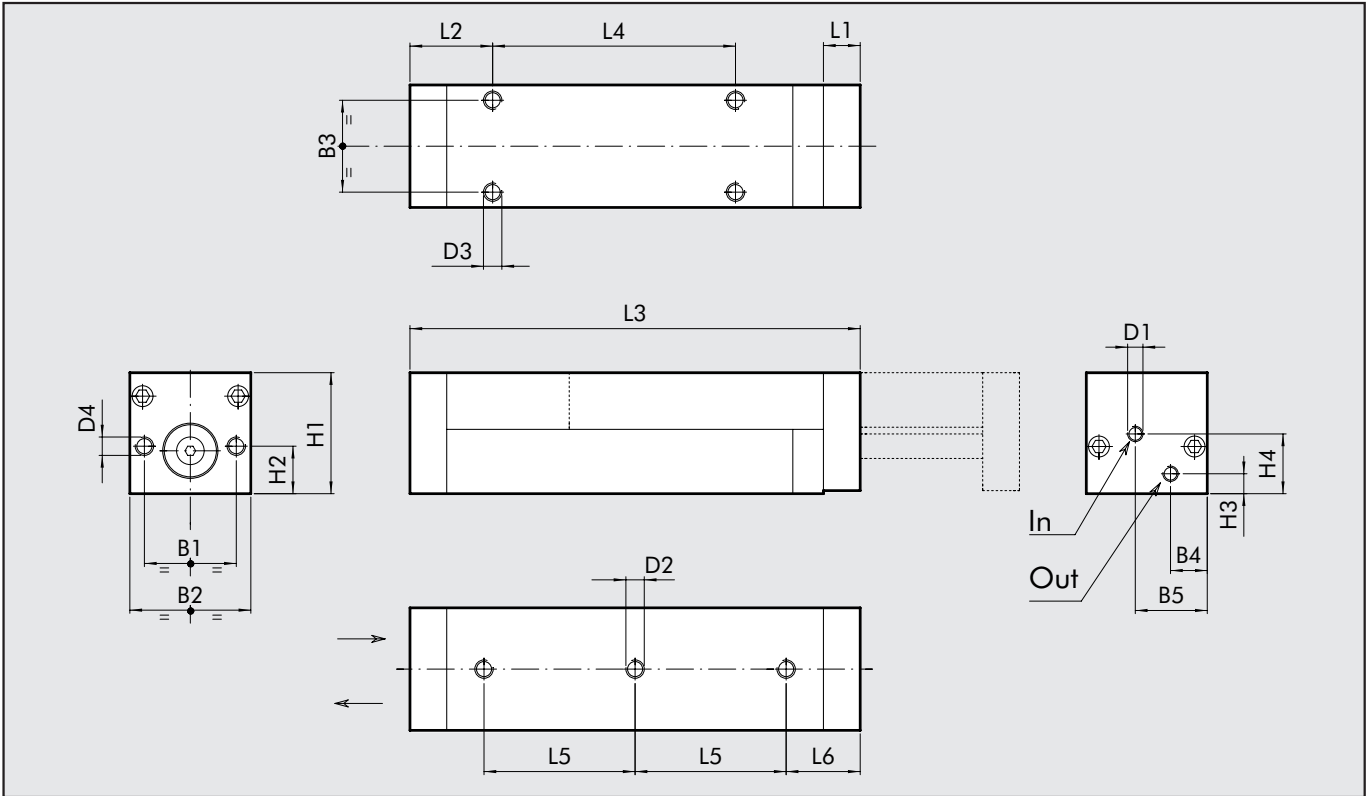

Bore Ø (mm)	Piston rod bore Ø (mm)	B1 (mm)	B2 (mm)	B3 (mm)	B4 (mm)	B5 (mm)	D1	D2 Thread/ Depth (mm)	D3 Thread/ Depth (mm)	D4 Thread/ Depth (mm)	H1 (mm)	H2 (mm)	H3 (mm)	H4 (mm)	L1 (mm)	L2 (mm)
10	5	26	35	25	12.0	21	M5	M6/5.5	M5/10	M6/11.5	26	10.5	5.0	14.0	12	27
16	8	30	40	30	13.0	25.5	M5	M6/5.5	M6/12	M6/11.5	32	12.0	7.5	15.5	12	27
20	8	30	40	30	12.5	24.5	M5	M6/8.0	M6/14	M6/11.5	39.5	15.5	8.0	20.0	12	22
25	10	35	55	39	17.5	34.75	G 1/8"	M8/7.5	M8/18	M8/10.5	45	19.0	12.0	23.0	15	35
32	12	45	65	49	20.0	40.5	G 1/8"	M8/7.5	M8/20	M8/10.5	50	20.0	10.8	28.3	15	35

Bore (mm)		(mm) Stroke							
		10	25	50	80	100	125	160	200
10/16	L3	80	95	135	175	200	245	305	360
	L4	15	30	70	2 x 55	2 x 67.5	2 x 90	2 x 120	2 x 147.5
	L5	31	2 x 23	2 x 43	3 x 42	3 x 50	3 x 65	3 x 85	4 x 78
	L6	24	24	24	24	24.5	24.5	24.5	23.5
Weight [g]		190/290	240/380	340/530	440/630	540/730	590/880	780/1080	890/1280
20	L3	80	95	135	175	200	245	305	360
	L4	25	30	70	2 x 55	2 x 67.5	2 x 90	2 x 120	2 x 147.5
	L5	31	2 x 23	2 x 43	3 x 42	3 x 50	3 x 65	3 x 85	4 x 78
	L6	24	24	24	24	24.5	24.5	24.5	23.5
Weight [g]		390	440	580	730	830	1030	1280	1530
25/32	L3	101	121	156	211	246	286	341	411
	L4	20	40	75	130	2 x 82.5	2 x 102.5	2 x 130	2 x 165
	L5	45	65	2 x 50	2 x 78	2 x 95	3 x 77	3 x 95	3 x 115
	L6	27.5	27.5	27.5	27	27.5	27	27.5	32.5
Weight [g]		640/840	740/1000	1000/1300	1340/1740	1540/2040	1840/2400	2200/2840	2600/3440



**DIMENSIONS OF COMPACT PRECISION SLIDES SERIES S8-C, COMPLETE**

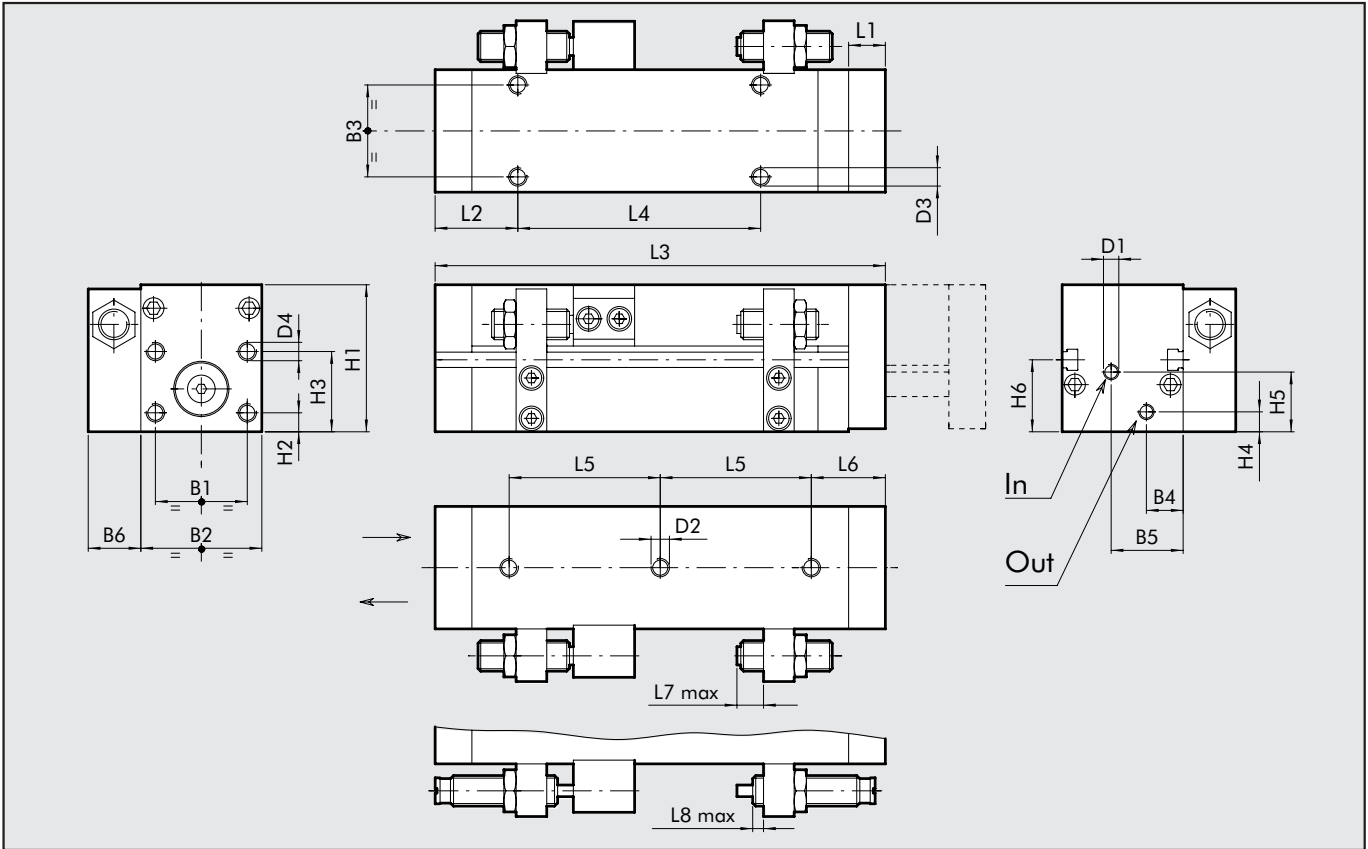

Bore Ø (mm)	Piston rod bore Ø (mm)	B1 (mm)	B2 (mm)	B3 (mm)	B4 (mm)	B5 (mm)	B6 (mm)	D1	D2 Thread/ Depth (mm)	D3 Thread/ Depth (mm)	D4 Thread/ Depth (mm)	H1 (mm)	H2 (mm)	H3 (mm)	H4 (mm)	H5 (mm)	L1 (mm)	L2 (mm)	L7 (mm)	L8 (mm)
20	8	28	40	30	12.5	24.5	17	M5	M6/8.0	M6/14	M6/11.5	48	6.2	26.2	8.0	20.0	12	27	5	16
25	10	35	55	39	17.5	34.75	22	G 1/8"	M8/7.5	M8/15	M8/10.5	60	10.2	35.2	11.0	24.0	15	35	5	16
32	12	45	65	49	20.0	40.5	22	G 1/8"	M8/7.5	M8/20	M8/10.5	70	10.2	40.2	10.8	28.3	15	35	5	16

Bore (mm)		(mm) Stroke						
		25	50	80	100	125	160	200
20	L3	135	175	200	245	305	360	440
	L4	70	2 x 55	2 x 67.5	2 x 90	2 x 120	2 x 147.5	3 x 125
	L5	2 x 43	3 x 42	3 x 50	3 x 65	3 x 85	4 x 78	4 x 98
	L6	24	24	24.5	24.5	24.5	23.5	23.5
Weight [g]		830	910	1010	1250	1510	1740	2160
25/32	L3	156/211	211	246	286	341	411	501
	L4	75/130	130	2 x 82.5	2 x 102.5	2 x 130	2 x 165	3 x 140
	L5	2 x 50/2 x 78	2 x 78	2 x 95	3 x 77	3 x 95	3 x 115	4 x 110
	L6	27.5/27	27	27.5	27	27.5	32.5	30.0
Weight [g]		1500/2200	1800/2520	2160/2900	2540/3360	3020/4000	3685/4860	4445/5740

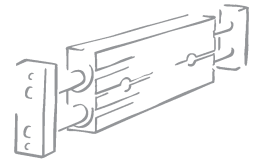

### KEY TO CODES FOR S8-B PRECISION SLIDE

W 1 4 8 B	1 0	O	0 5 0
TYPE	DIAMETER	VARIANT	STROKE
Precision slide series S8 type B	10 16 20 25 32	0 non-magnetic 6* non-magnetic, cushioned fixed, pneumatic	10 mm 25 mm 50 mm 80 mm 100 mm 125 mm 160 mm 200 mm
		* starting from Ø20 and stroke 80	

### KEY TO CODES FOR S8-C PRECISION SLIDE

W 1 4 8 C	2 0	O	0 5 0
TYPE	DIAMETER	VARIANT	STROKE
Precision slide series S8 type C	20 25 32	0 magnetic 6* magnetic with fixed pneum. cushioning 7 magnetic with mechanical stop 4 magnetic with hydraulic shock absorber 8* magnetic with mech. stop and fixed pneum. cushioning	25 mm 50 mm 80 mm 100 mm 125 mm 160 mm 200 mm
		* starting from stroke 50	

### RETRACTABLE SENSOR WITH INSERTION FROM ABOVE

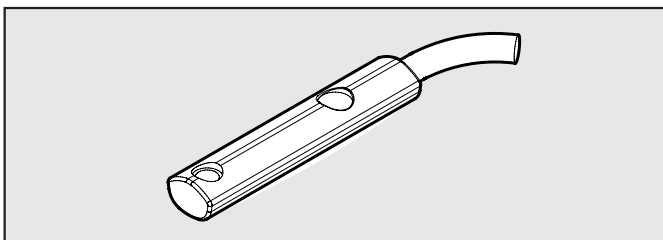

Code	Description
W0952025390	HALL N.O. SENSOR, VERTICAL INSERTION 2.5m
W0952029394	HALL N.O. SENSOR, VERTICAL INSERTION 300 mm M8
W0952022180	REED N.O. SENSOR, VERTICAL INSERTION 2.5m
W0952028184	REED N.O. SENSOR, VERTICAL INSERTION 300 mm M8
W0952125556	HALL N.O. SENSOR, VERTICAL INSERTION 2m ATEX

This type of sensor can be inserted in the slot of the sensor from above. This means the cylinder heads do not require a through opening.

### WIRING DIAGRAM

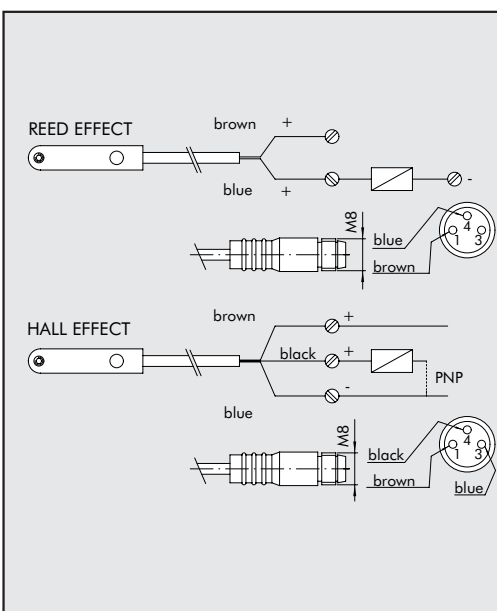

### TECHNICAL DATA

	Reed	Effetto Hall	Effetto Hall
Type of contact	N.O.	N.O.	N.O.
Switch	-	PNP	PNP
Supply voltage (U <sub>b</sub> )	V 10 ÷ 30 AC/DC	10 ÷ 30 DC	18 ÷ 30 DC
Power	W 3 (peak valve=6)	3	≤ 1.7
Voltage variation	-	≤ 10% di U <sub>b</sub>	≤ 10% di U <sub>b</sub>
Voltage drop	V -	≤ 2	≤ 2.2
Input current	mA -	≤ 10	≤ 10
Output current	mA ≤ 100	≤ 100	≤ 70
Switching frequency	Hz ≤ 400	≤ 5000	1000
Short-circuit protection	-	Yes	Yes
Over-voltage suppression	-	Yes	Yes
Polarity inversion protection	-	Yes	Yes
EMC	EN 60 947-5-2	EN 60 947-5-2	EN 60 947-5-2
LED display	Yellow	Yellow	Yellow
Magnetic sensitivity	2,8 mT ± 25%	2,8 mT ± 25%	2.6
Repeatability	≤ 0,1 mT	≤ 0,1 mT	≤ 0,1 (U <sub>b</sub> and ta fixed)
Degree of protection (EN 60529)	IP 67	IP 67	IP 68, IP 69K
Vibration and shock resistance	30 g, 11 ms, 10÷55 Hz, 1mm	30 g, 11 ms, 10÷55 Hz, 1mm	30 g, 11 ms, 10÷55 Hz, 1mm
Temperature range	°C -25 ÷ +75	-25 ÷ +75	-20 ÷ +45
Sensor capsule material	PA66 + PA6I/6T	PA66 + PA6I/6T	PA
2.5m/2m connecting cable	PVC; 2 x 0,12 mm <sup>2</sup>	PVC; 3 x 0,14 mm <sup>2</sup>	PVC; 3 x 0,12 mm <sup>2</sup>
Connecting cable with M8x1	Polyurethane; 2 x 0,14 mm <sup>2</sup>	Polyurethane; 3 x 0,14 mm <sup>2</sup>	-
Wire NO.	2	3	3