

ROTARY ACTUATOR SERIE R3 WITH EXTERNAL SHOCK ABSORBERS

Dual-rack actuator with automatic adjustment for wear. Hydraulic shock absorbers are arranged externally and operate at a distance from the axis of rotation which is considerably higher than for internal ones. This means that the absorbable kinetic energy is 4 to 8 times higher. It is reduced in length as there are no adjusting screws. A 90° and a 180° versions are available. Grooves are provided in the body to fix retractable magnetic proximity sensors, two on each side. A hole has been drilled in the flange for the passage of air pipes or power cables.

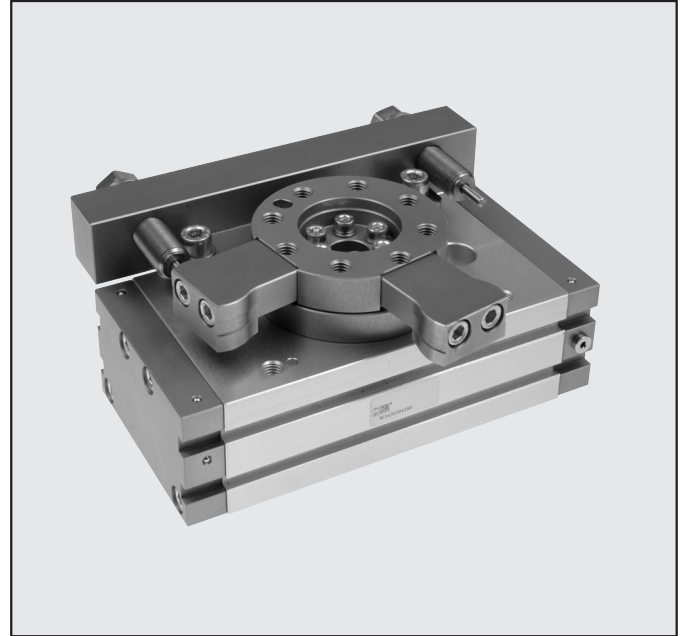

We always suggest to use flow microregulators. During the setup of the actuator, start with CLOSE flow microregulators, and open gradually till the achievement of the required speed.

TECHNICAL FEATURES	R3 - 16	R3 - 20	R3 - 22	R3 - 25	R3 - 30	R3 - 40
Pressure range	bar da 3 a 7					
Temperature range	°C da 5° a 60°					
Angle adjustment	degrees 90° o 180° ±3°					
Fluid	20µm dried or lubricated filtered air. Lubrication, if used, must be continuous					
Sizes	16	20	22	25	30	40
Bore	mm 2 x 16	2 x 20	2 x 22	2 x 25	2 x 30	2 x 40
Theoretical torque at a 6 bar	Nm 0.9	1.8	2.7	4.6	9.3	22
Max. axial load	N 74	135	195	300	340	360
Max. radial load	N 78	137	360	450	490	560
Max overturning moment	Nm 2,4	4	5,3	9,7	12	18
Admissible kinetic energy	J 0,16	0,55	0,85	1,40	1,85	3,35
Rotation time without load	s 0.2	0.2	0.2	0.2	0.3	0.3

COMPONENTS

- ① ROTARY FLANGE: anodised aluminium
- ② PINION: hardened and tempered steel
- ③ BALL BEARING
- ④ PISTON / RACK: hardened and tempered steel
- ⑤ CUSHIONING GASKET: NBR
- ⑥ GUIDE SHOE: PTFE
- ⑦ MAGNET: neodymium
- ⑧ HEAD: anodised aluminium
- ⑨ JACKET: anodised aluminium
- ⑩ STROKE REGULATOR WITH HYDRAULIC SHOCK ABSORBERS
- ⑪ Block for 90° version

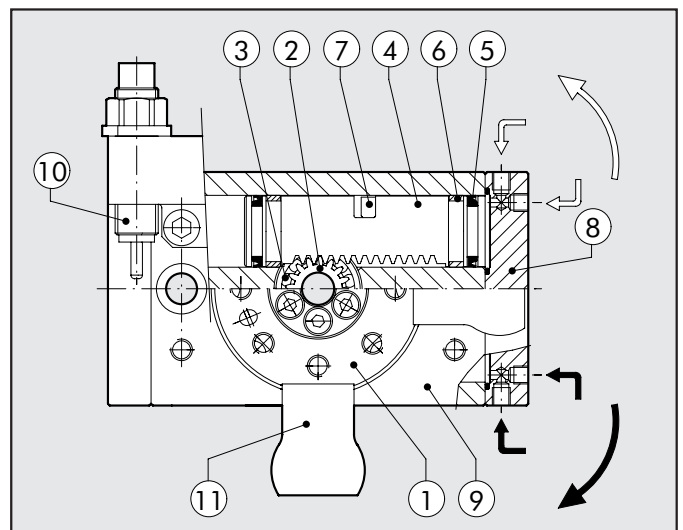

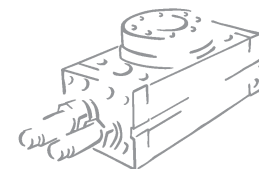

ROTATION ANGLE

1

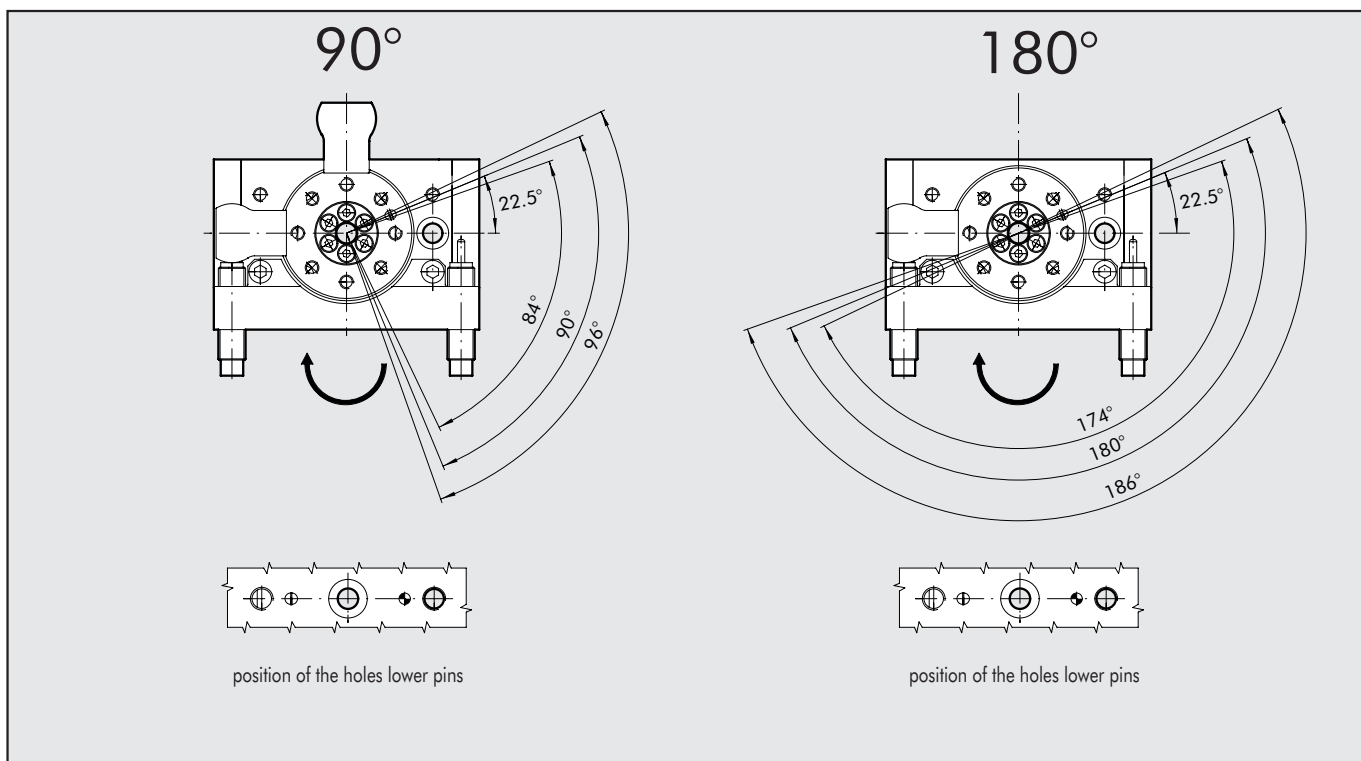

DIMENSIONES - FORCES AND MOMENTS

Ø	T Theoretical torque at 6 bar [Nm]	FA Max. axial load [N]	FR Max. radial load [N]	M Averturing momnet [Nm]
16	0.9	74	78	2.4
20	1.8	135	137	4
22	2.7	195	360	5.3
25	4.6	300	450	9.7
30	9.3	340	490	12
40	22	360	560	18

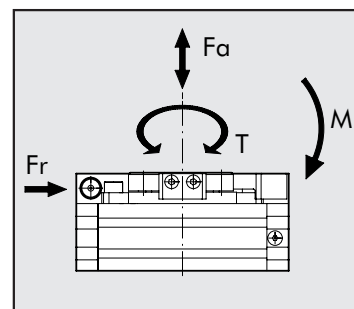

ADMISSIBLE KINETIC ENERGY Joule [J]

Ø	with flange, 90° rotation°: W1630_4090 with flange, 180° rotation°: W1630_4180
16	0,16
20	0,55
22	0,85
25	1,40
30	1,85
40	3,35

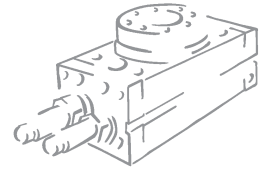

ROTARY ACTUATOR SERIES R3-22 WITH EXTERNAL SHOCK ABSORBERS, 90/180°

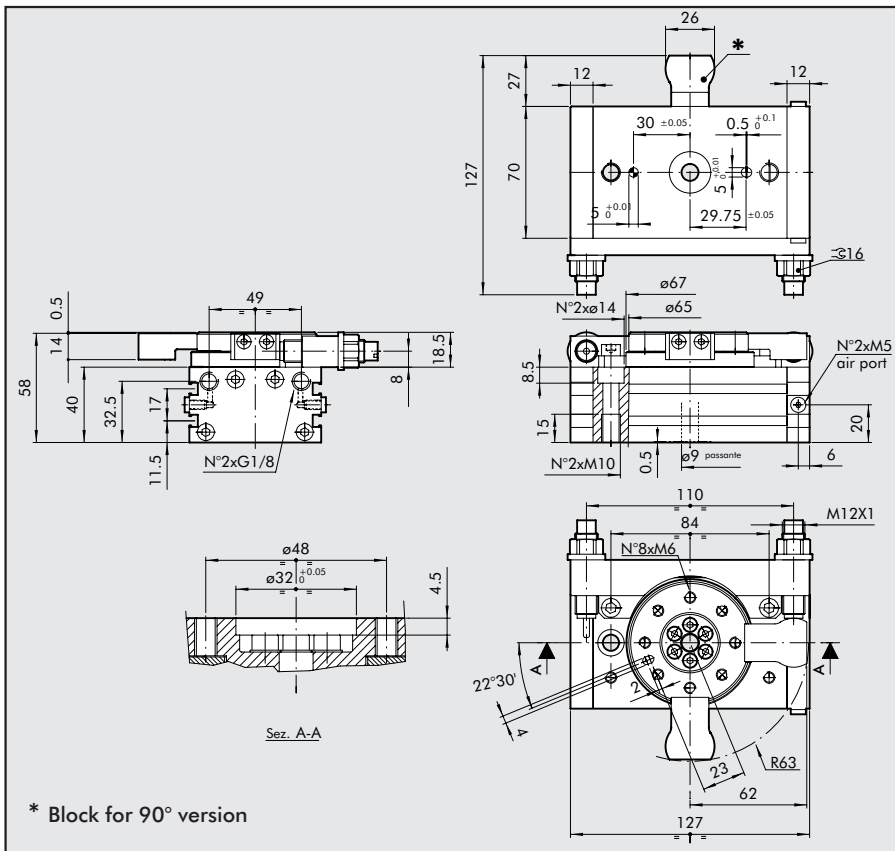

ORDERING CODES

Code	Description
W1630224090	ROTARY ACTUATOR WITH FLANGE + SHOCK ABSORBERS R3-22-90
W1630224180	ROTARY ACTUATOR WITH FLANGE + SHOCK ABSORBERS R3-22-180

ROTARY ACTUATOR SERIES R3-25 WITH EXTERNAL SHOCK ABSORBERS, 90/180°

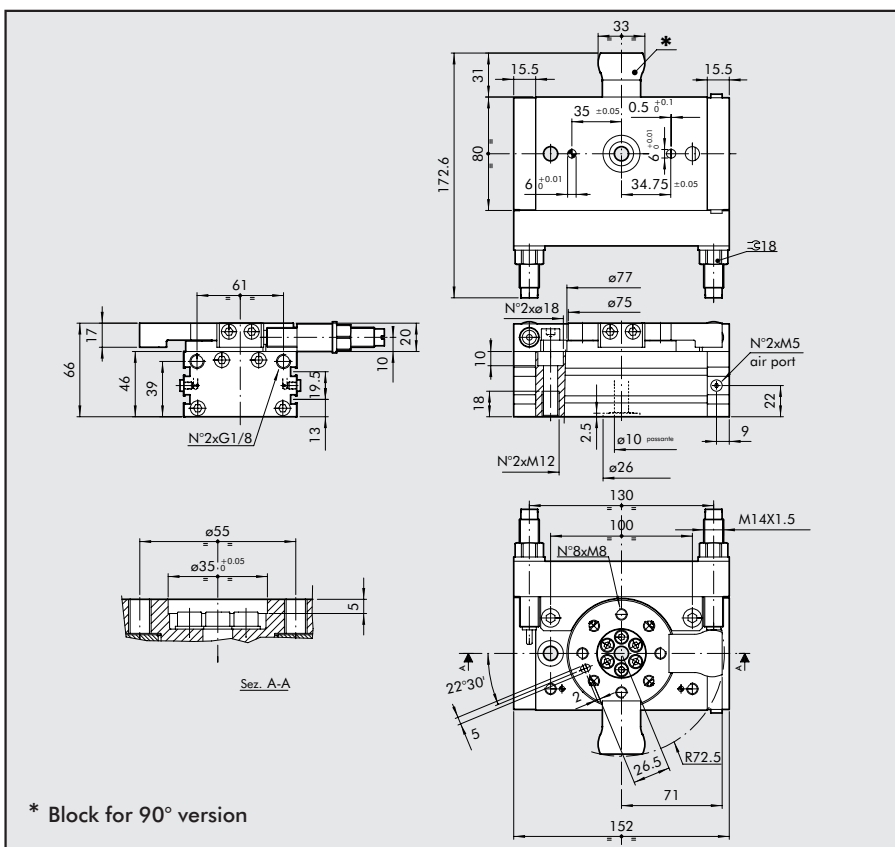

ORDERING CODES

Code	Description
W1630254090	ROTARY ACTUATOR WITH FLANGE + SHOCK ABSORBERS R3-25-90
W1630254180	ROTARY ACTUATOR WITH FLANGE + SHOCK ABSORBERS R3-25-180

ROTARY ACTUATOR SERIES R3-30 WITH EXTERNAL SHOCK ABSORBERS, 90/180°

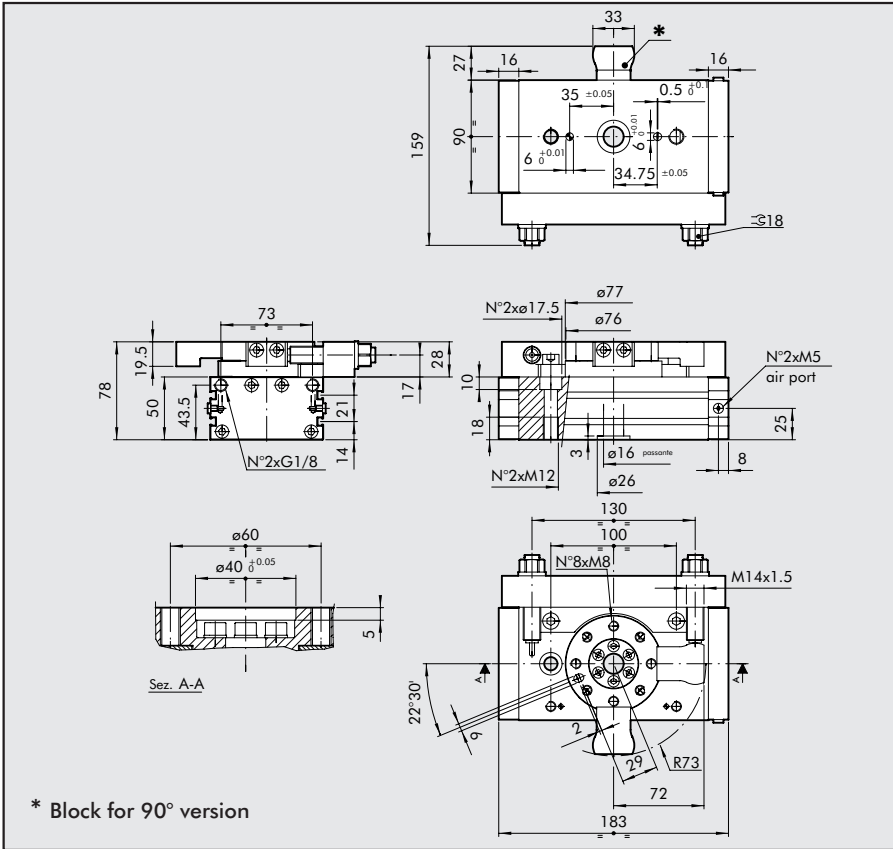

ORDERING CODES

Code	Description
W1630304090	ROTARY ACTUATOR WITH FLANGE + SHOCK ABSORBERS R3-30-90
W1630304180	ROTARY ACTUATOR WITH FLANGE + SHOCK ABSORBERS R3-30-180

ROTARY ACTUATOR SERIES R3-40 WITH EXTERNAL SHOCK ABSORBERS, 90/180°

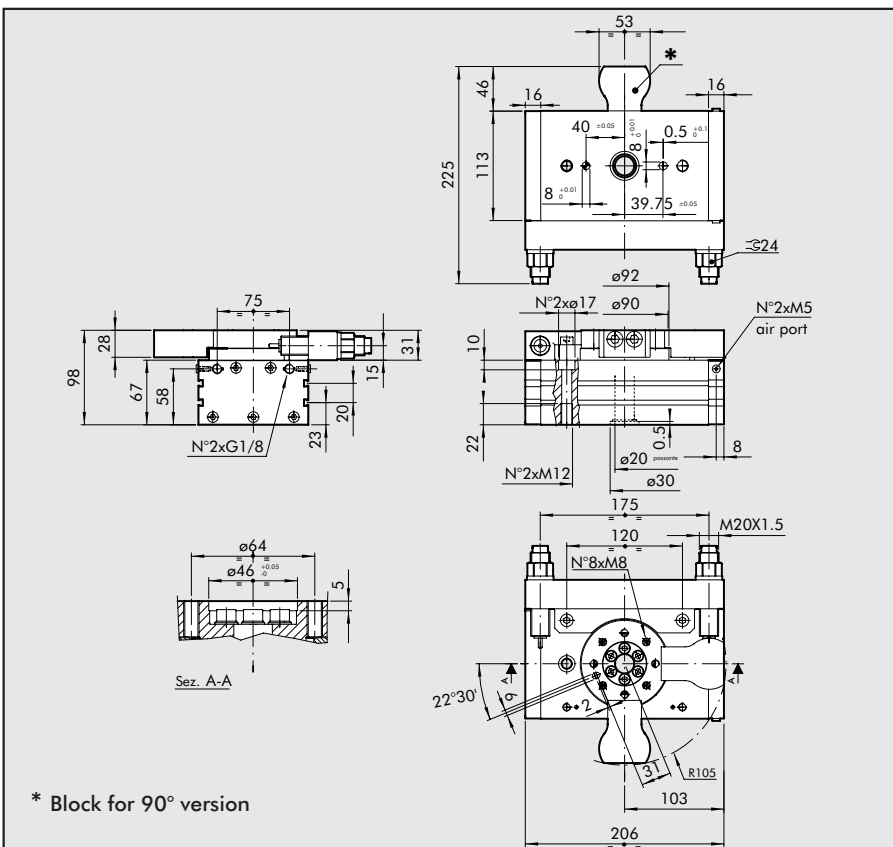

ORDERING CODES

Code	Description
W1630404090	ROTARY ACTUATOR WITH FLANGE + SHOCK ABSORBERS R3-40-90
W1630404180	ROTARY ACTUATOR WITH FLANGE + SHOCK ABSORBERS R3-40-180

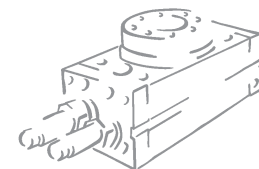

ACCESSORIES

RETRACTABLE SENSOR WITH INSERTION FROM ABOVE

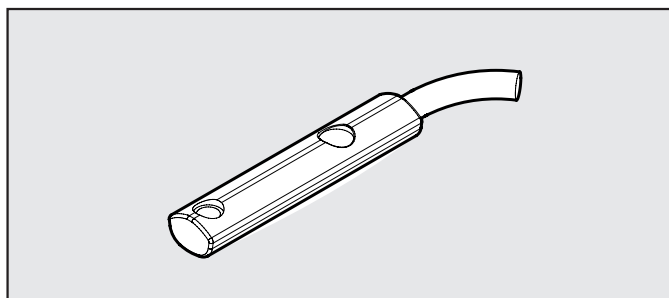

Code	Description
W0952025390	HALL N.O. SENSOR, VERTICAL INSERTION 2.5m
W0952029394	HALL N.O. SENSOR, VERTICAL INSERTION 300 mm M8
W0952022180	REED N.O. SENSOR, VERTICAL INSERTION 2.5m
W0952028184	REED N.O. SENSOR, VERTICAL INSERTION 300 mm M8
W0952125556	HALL N.O. SENSOR, VERTICAL INSERTION 2m ATEX

This type of sensor can be inserted in the slot of the sensor from above. This means the cylinder heads do not require a through opening.

WIRING DIAGRAM

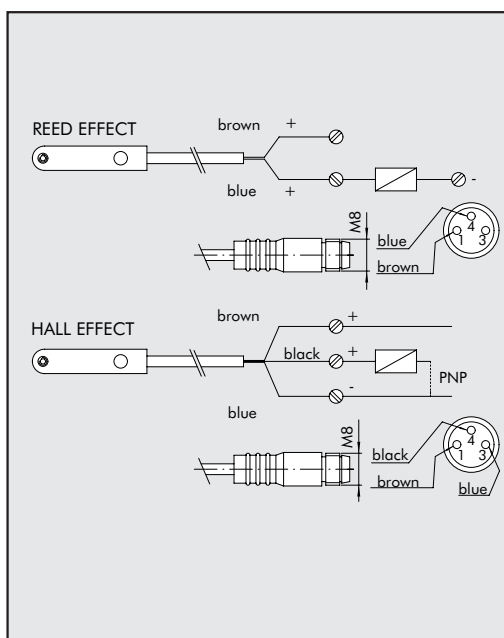

TECHNICAL DATA

	Reed	Effetto Hall	Effetto Hall
Type of contact	N.O.	N.O.	N.O.
Switch	-	PNP	PNP
Supply voltage (U _b)	V 10 ÷ 30 AC/DC	10 ÷ 30 DC	18 ÷ 30 DC
Power	W 3 (peak valve=6)	3	≤ 1.7
Voltage variation	-	≤ 10% di U _b	≤ 10% di U _b
Voltage drop	V -	≤ 2	≤ 2.2
Input current	mA -	≤ 10	≤ 10
Output current	mA ≤ 100	≤ 100	≤ 70
Switching frequency	Hz ≤ 400	≤ 5000	1000
Short-circuit protection	-	Yes	Yes
Over-voltage suppression	-	Yes	Yes
Polarity inversion protection	-	Yes	Yes
EMC	EN 60 947-5-2	EN 60 947-5-2	EN 60 947-5-2
LED display	Yellow	Yellow	Yellow
Magnetic sensitivity	2,8 mT ±25%	2,8 mT ±25%	2.6
Repeatability	≤ 0,1 mT	≤ 0,1 mT	≤ 0,1 (U _b and ta fixed)
Degree of protection (EN 60529)	IP 67	IP 67	IP 68, IP 69K
Vibration and shock resistance	30 g, 11 ms, 10÷55 Hz, 1mm	30 g, 11 ms, 10÷55 Hz, 1mm	30 g, 11 ms, 10÷55 Hz, 1mm
Temperature range	°C -25 ÷ +75	-25 ÷ +75	-20 ÷ +45
Sensor capsule material	PA66 + PA6I/6T	PA66 + PA6I/6T	PA
2.5m/2m connecting cable	PVC; 2 x 0,12 mm ²	PVC; 3 x 0,14 mm ²	PVC; 3 x 0,12 mm ²
Connecting cable with M8x1	Polyurethane; 2 x 0,14 mm ²	Polyurethane; 3 x 0,14 mm ²	-
Wire NO.	2	3	3

BAR FOR GROOVING

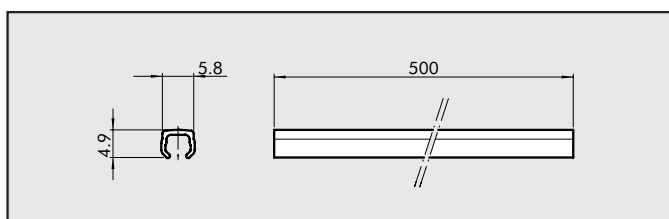

Code Description

W0950000160 BAR FOR GROOVING L=500 mm

SPARES

SHOCK ABSORBERS

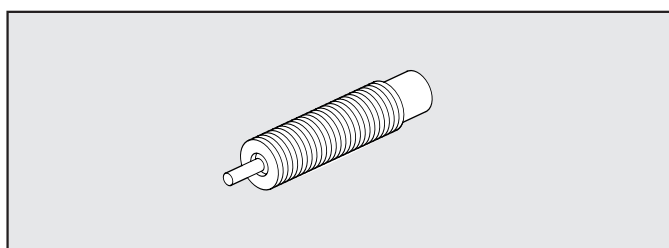

Code	Bore	Description
0950004009	ø16	Shock absorbers PMX 10 MF3 + nut M10x1
0950004010	ø22	Shock absorbers PM 15 MF3 + nut M12x1
0950004011	ø25-ø30	Shock absorbers SPM 25 MC-C + nut M14x1.5
0950004005	ø40	Shock absorbers PR50 MC2 + nut M20x1.5