

# ROTARY ACTUATORS

## TYPES

Rotary actuators come in the following types in terms of position:

- two positions, fixed or adjustable
- three positions, fixed or adjustable

Rotation is alternating in all the types shown in this catalogue. There also exist rotary actuators that always rotate in the same direction, with 4, 6, or more positions.

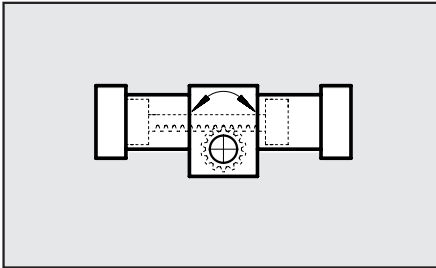

### Rotary actuator with single rack

A pinion is keyed onto the rotating part and is rotated by means of a rack. The rack is driven by two pneumatic pistons, one on either side.

As there is no play take-up system, it is not suitable for applications requiring accurate positioning. But there is a version with outer adjustable mechanical stops that stop the rotating part and also take up play.

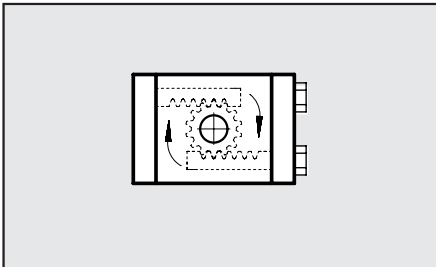

### Rotary actuator with double rack

The pinion keyed onto the rotating element is turned by two opposing racks, each driven by a pneumatic piston. The system has automatic play take-up, which means it is suitable for applications requiring accurate positioning. The parallelepiped shape of the design makes them ideal for use on mechanical arms.

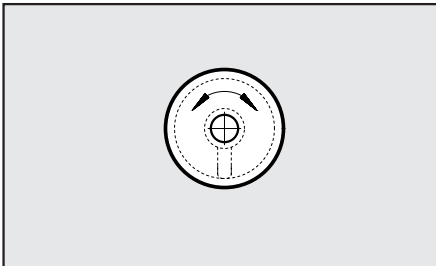

### Blade-type rotary actuator

The rotating element is connected to one or two blades inside a cylindrical chamber. The air pressure on one of the sides of the blade rotates the element. These are compact, cylindrical actuators designed for manipulation where particularly accuracy and high loads are not required.

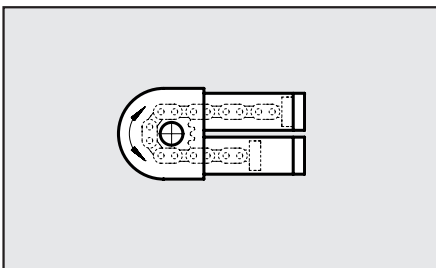

### Chain-type rotary actuator

A chain that is stretched at either end by a pneumatic piston winds round and rotates a pinion. This type of actuator is not included in our catalogue.

## NOTES

The use of hydraulic decelerators means it is possible to increase absorbed power. Some models in the catalogue have built-in decelerators. For those without, the user can mount decelerators outside the actuator.

With horizontal axis rotation, if the masses are distributed asymmetrically it may be difficult to keep a constant rotation speed using flow regulators only. In this case it is advisable to use a decelerator.

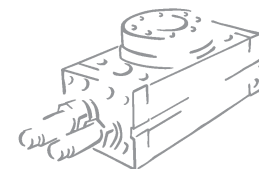

## RACK-TYPE ROTARY ACTUATORS

1

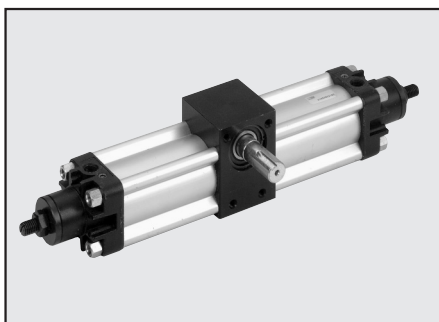

### Series R1

These are rotary actuators with a single rack driven by cylinders inside extruded jackets similar to ISO 15552 cylinders. The range includes thrust cylinders with 32 - 100 mm bore.

There is a fixed stroke version and one with a mechanically adjustable stroke.

Strokes available: 90°, 180°, 270° and 360°.

Magnets for standard sensors.

The rotating part ends in a shaft or a hole with a spanner slot. This type features a plain yet sturdy construction and is relatively inexpensive.



### Series R2

These are actuators with a double rack and play take-up, and have a shaft with a spanner slot.

Strokes 90° and 180°. Stroke adjustment using screws. Pneumatic end-of-stroke cushioning.

Magnets for position sensors.

Compact and inexpensive. The smallest size measures a mere 46 x 65 x 28 mm.

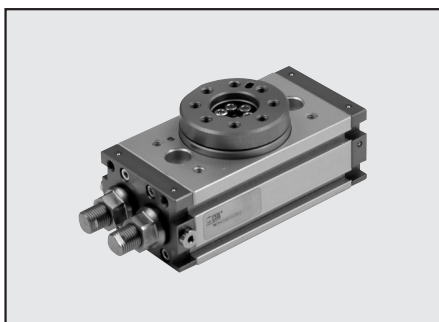

### Series R3

These are actuators with a double rack, play take-up and flange.

Strokes available regulation from 0° to 180°.

Versions with a mechanical stop or hydraulic end-of-stroke cushioning.

Magnets for position sensors.

There is a hole in the flange for air pipes or wires.

## BLADE ROTARY ACTUATORS

This catalogue does not include blade-type rotary actuators, but we can supply models with one or two blades on specific request.

There are numerous options:

- Fixed stroke version: angle of rotation 90°, 180° or 270°.
- Adjustable stroke version
- Induction sensors

Mounting accessories: flange or one or two brackets.

## CALCULATIONS

The following needs to be calculated:

- Absorbed kinetic energy
- Axial forces on the shaft or rotating flange
- Radial force on the shaft or rotating flange
- Overturning moment

Then compare each of the 4 sizes with the admissible ones shown in the catalogue for each rotary actuator. Remember that the application of optional hydraulic decelerator, where envisaged, doubles the kinetic energy that can be absorbed by the actuator.

## ROTARY ACTUATOR COMPARATIVE CHART

The lines plotted on the graph below show the following for each series of actuators:

- Possible torque (at 6 bar)
- Length (for actuator with 180° rotation)

This allow you to determine the most appropriate series to meet your requirements. For instance, if you want a rotary actuator with torque greater than 100 N and length less than 300 mm, you can find it in series R3.

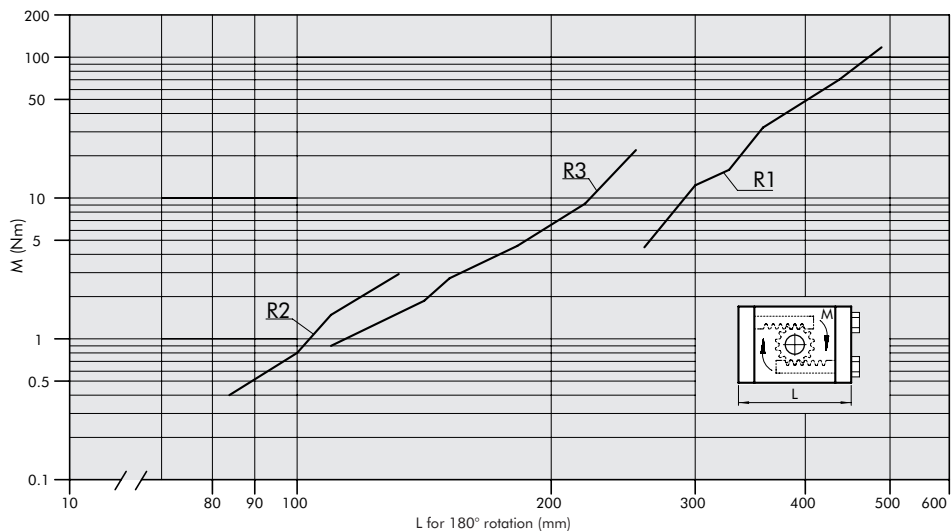

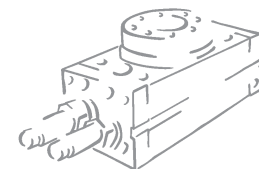

# SIZING

1

## HOW TO CALCULATE KINETIC ENERGY

	Denomination	Unit of measurement	Formula	Example
$\alpha$	Angle of rotation	rad	$= \text{degrees} \cdot \frac{\pi}{180}$	$= 90^\circ = \frac{\pi}{2} \text{ rad.}$
t	Rotation time	s		2
Jta	Moment of inertia of rotating masses N.B.: sommare quello delle singole masse	Kg m <sup>2</sup>	$= \sum J_i$	$= 0.078 + 0.02 + 0.133 = 0.232$
E	Energia cinetica	Nm	$= 1/2 J \omega^2 = 1/2 J \cdot \left(\frac{\alpha}{t}\right)^2$	$= 1/2 \cdot 0.232 \cdot \left(\frac{\pi}{2}\right)^2 = 0.57$
Fr	Radial force (Remember to take into account centrifugal forces)	N	$(F_c = M \cdot \omega^2 \cdot R)$	50
Fa	Axial force	N		10
M	Overturning moment	Nm	$= M + Fr \cdot a + Fa \cdot b$	$= 50 \times 0.1 + 10 \times 0 = 5 \text{ Nm}$

## MOMENTS OF INERTIA FOR THE MOST COMMON SHAPES

	Denomination	Unit of measurement	Formula	Example
M	Disk mass	Kg	Disco 	7
d	Disk diameter	m		0.3
J	Moment of inertia of the disk	Kg m <sup>2</sup>	$= \frac{Md^2}{8}$	$= \frac{7 \cdot 0.3^2}{8} = 0.0787$
M	Mass	Kg	Mass distant from rotation axis 	0.5
R	Distance between barycenter and rotation axis	m		0.2
J	Moment of inertia of the mass	Kg m <sup>2</sup>	$= MR^2$	$= 0.5 \times 0.2^2 = 0.02$
M	Mass	Kg	Parallelepiped with barycenter on rotation axis 	10
L	Side of the parallelepiped	m		0.4
J	Moment of inertia of the mass	Kg m <sup>2</sup>		$= M \frac{L^2}{12}$