

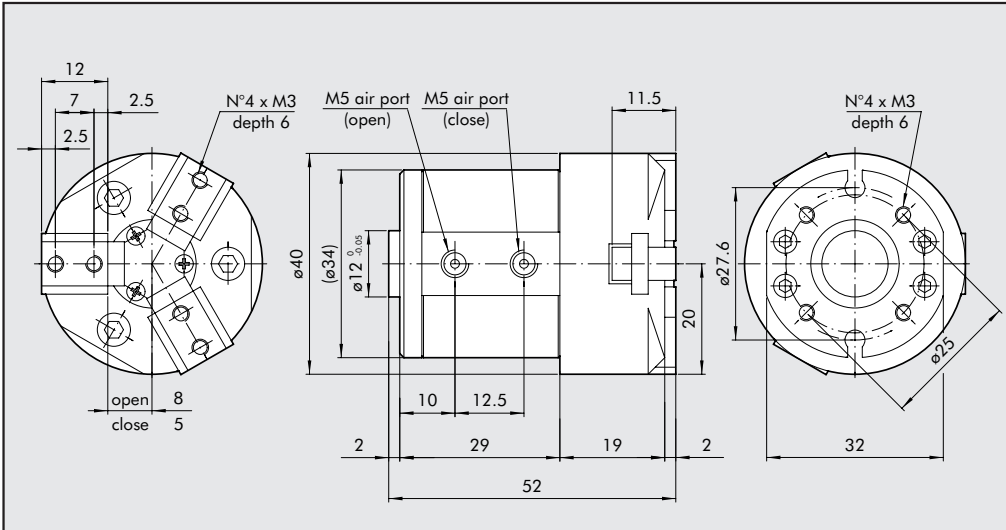



**DIMENSIONS OF GRIPPER P11-16**



**ORDERING CODES**

Code	Description
W1570160300	GRIPPERS WITH 3 PARALLEL JAWS P11-16

**DIMENSIONS OF GRIPPER P11-20**

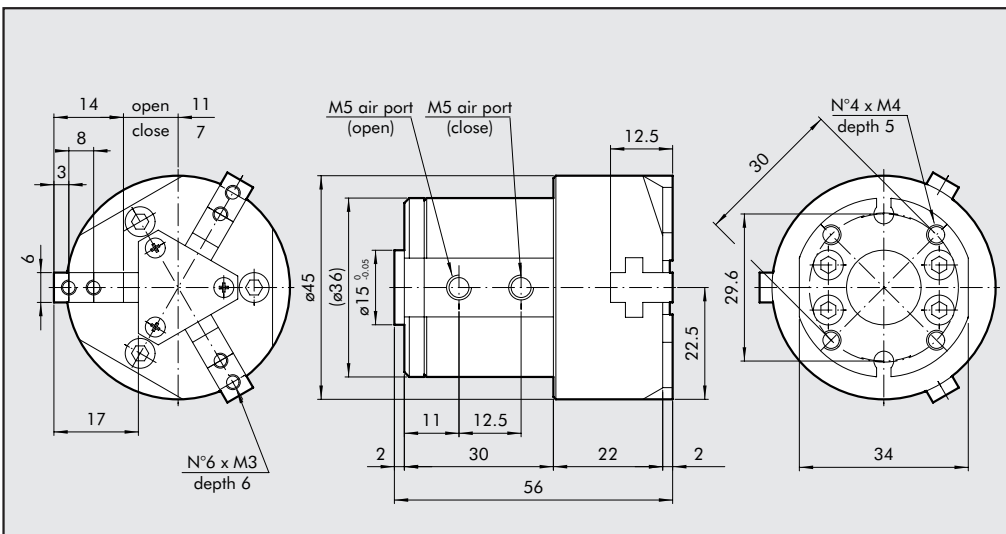

**ORDERING CODES**

Code	Description
W1570200300	GRIPPERS WITH 3 PARALLEL JAWS P11-20

**DIMENSIONS OF GRIPPER P11-25**

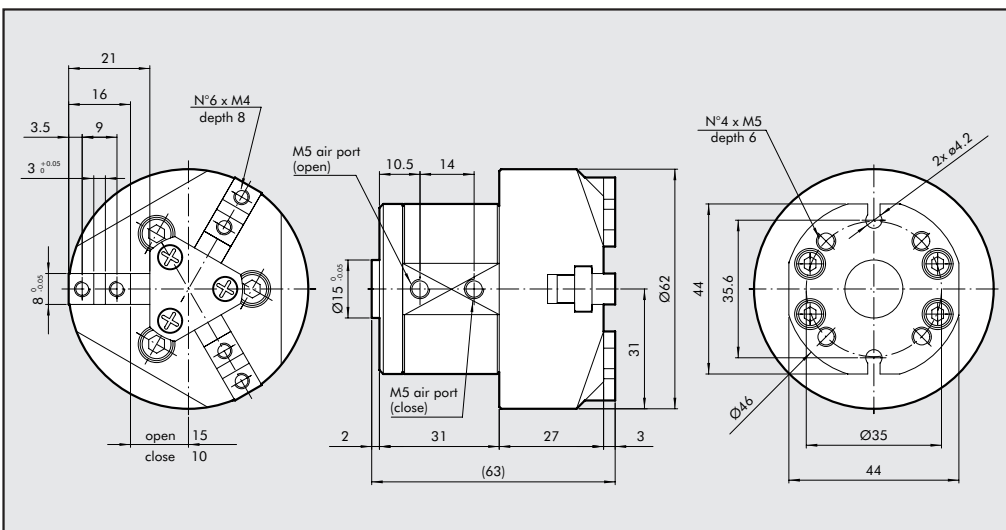

**ORDERING CODES**

Code	Description
W1570250300	GRIPPERS WITH 3 PARALLEL JAWS P11-25

### DIMENSIONS OF GRIPPER P11-60

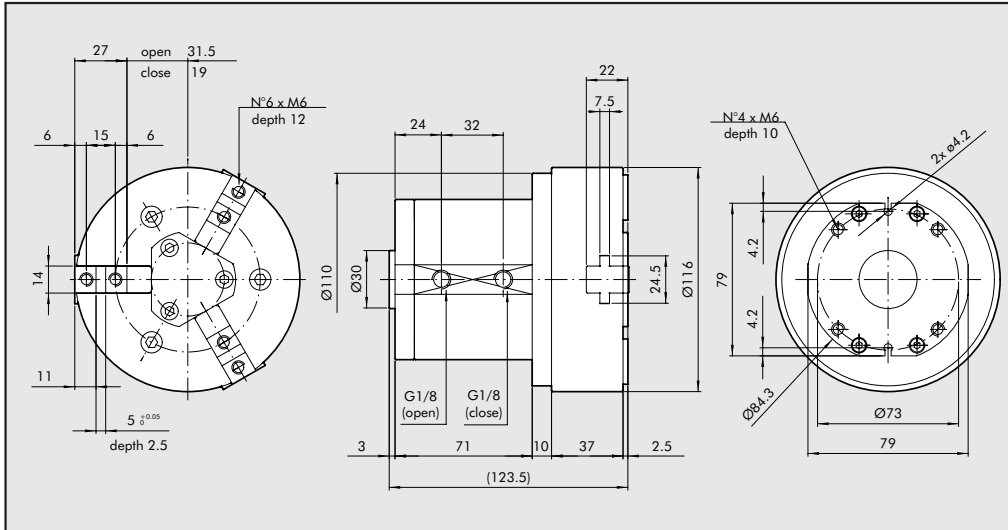

### ORDERING CODES

Code	Description
W1570600300	GRIPPERS WITH 3 PARALLEL JAWS P11-60

## ACCESSORIES

### SENSOR FOR P11-16 ÷ 60

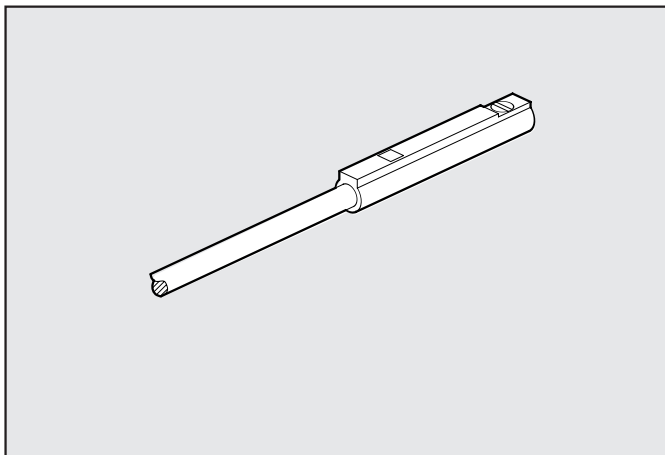

Code	Description
W0950044180	Sensor REED 2 wires 24 VDC 1m
W0950045390*	Sensor HALL 3 wires 24 VDC 2m

\*N.B.: for technical data of sensor, see pag. 1.2/24

### NOTES