

# TOGGLE GRIPPERS SERIES P10

Toggle-type hinged grippers for gripping from outside with 20°-180° adjustable opening angle. One-degree adjustment for each jaw. The toggle system allows high clamping forces.

The body of the gripper is made of hardened aluminium, the moving parts of hardened and tempered steel. The body is designed to mount induction sensors.

The supply includes sensor holders, centring pins and O-rings for direct connection.

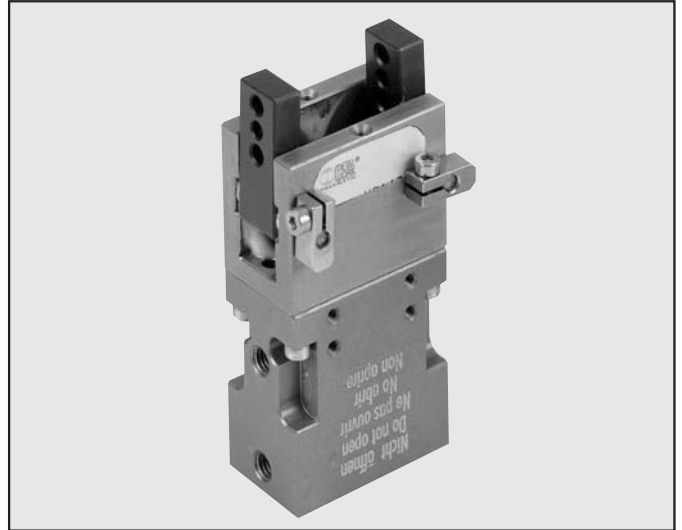

TECHNICAL FEATURES		P10 - 34	P10 - 44	P10 - 54	P10 - 80
Pressure range	bar	4.5 to 6.5			
Temperature range	°C	5°C to 60°C			
Fluid		20µm dried or lubricated filtered air; if used, it must be continuous			
Life without maintenance		over 2 million cycles			
Jaw opening angle		20° - 180° adjustable			
Clamping force per jaw at 6 bar	N	32 (L=11 mm)	90 (L=15 mm)	145 (L=17 mm)	275 (L=45 mm)
Clamping force of spring alone	N	14	40	55	115
Applicable weight (recommended)	Kg	0.3	0.9	1.4	2.7
Air consumption per cycle	cm <sup>3</sup>	4.5	16	36	110
Opening time	sec	0.4	0.5	0.7	0.8
Closing time	sec	0.3	0.4	0.6	0.7
Closing time with spring only	N	0.35	0.45	0.6	0.7
Weight of grippers	Kg	0.14	0.34	0.56	1.6
Moment of inertia	Kg cm <sup>2</sup>	0.2	0.8	2	12
Repeatability	mm	0.1	0.1	0.1	0.1
Maximum finger length	mm	75	100	115	150

## TABLE OF FORCES AND MOMENTS

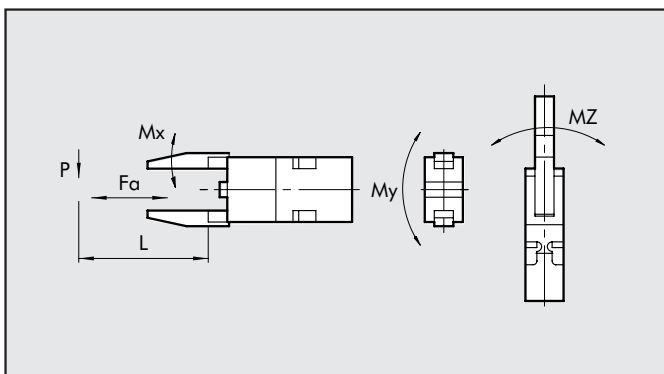

Gripper	FA (N)	Mx (Nm)	My (Nm)	Mz (Nm)	L (mm)	PN
P10 - 34	50	0.7	0.3	3.9	11	32
P10 - 44	100	2.7	0.5	6.2	15	90
P10 - 54	180	4.9	1	10	17	145
P10 - 80	400	24.8	1.6	17.5	45	225

## CLAMPING FORCE ACCORDING TO FINGER LENGTH

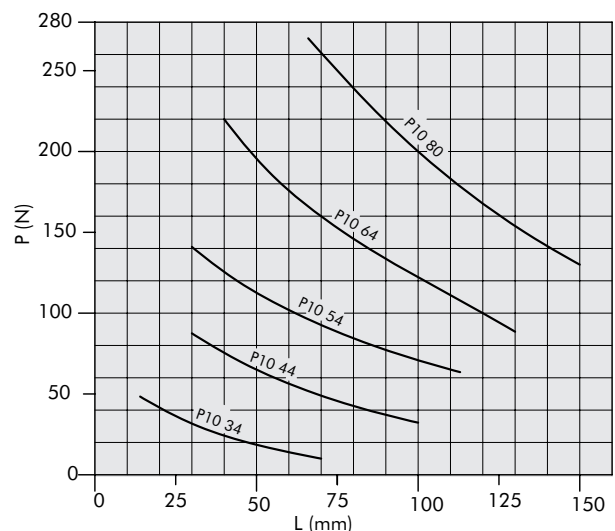

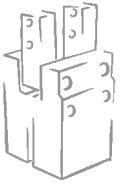

### DIMENSIONS OF GRIPPERS P10-34

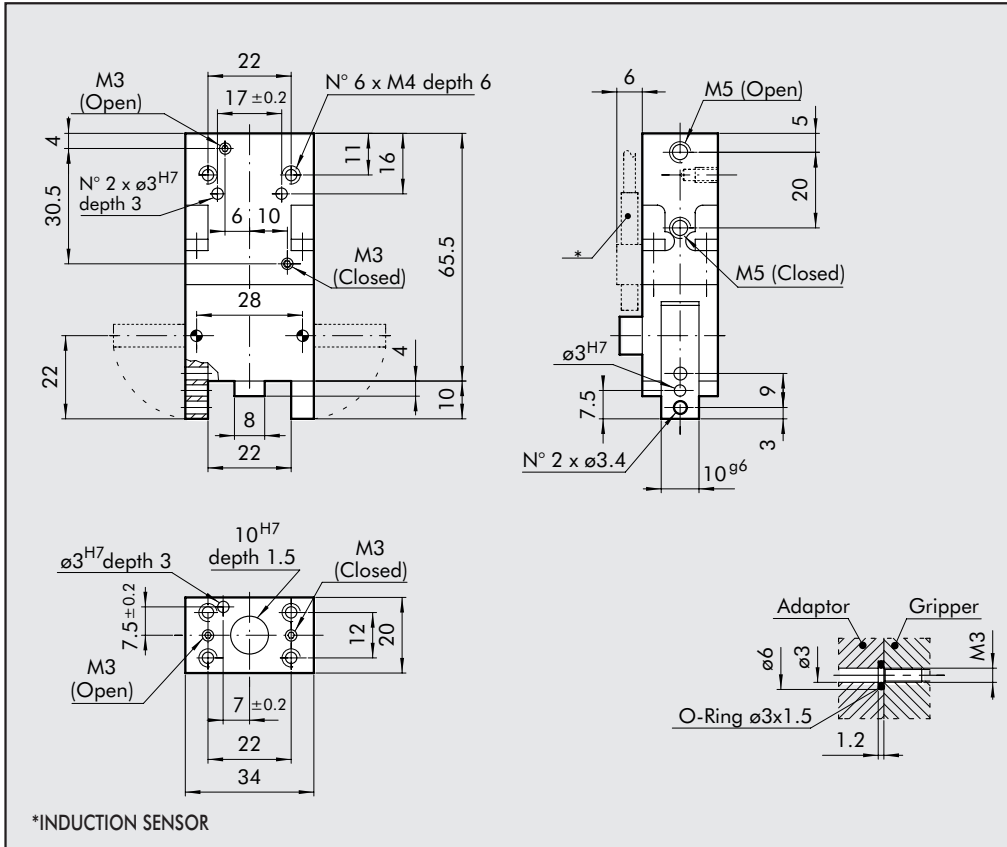

### ORDERING CODES

Code	Description
W1590340201	TOGGLE GRIPPERS P10-34

1

### DIMENSIONS OF GRIPPERS P10-44

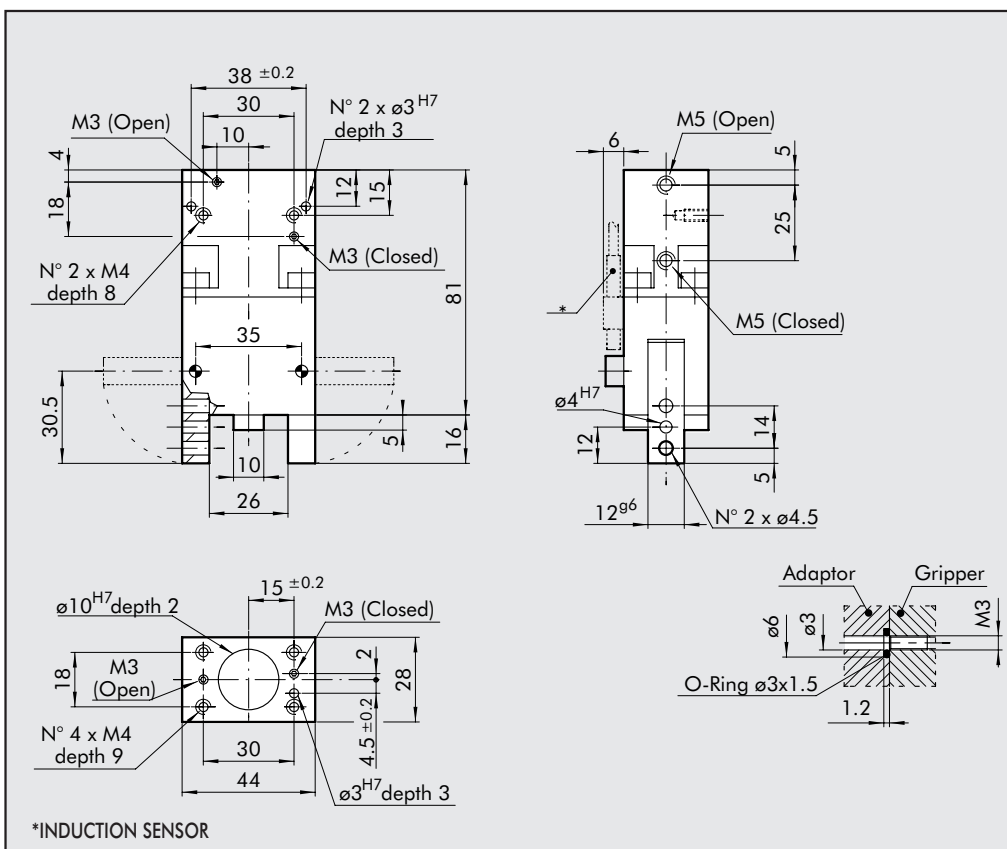

### ORDERING CODES

Code	Description
W1590440201	TOGGLE GRIPPERS P10-44

### DIMENSIONS OF GRIPPERS P10-54

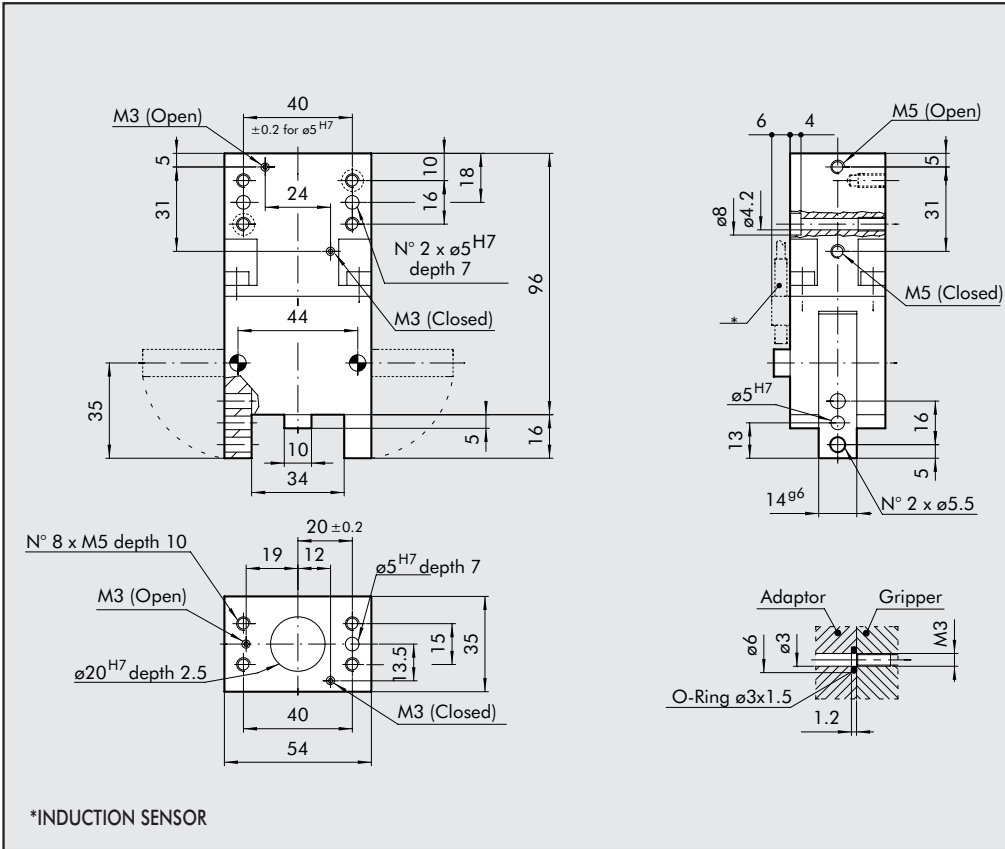

### ORDERING CODES

Code	Description
W1590540201	TOGGLE GRIPPERS P10-54

### DIMENSIONS OF GRIPPERS P10-80

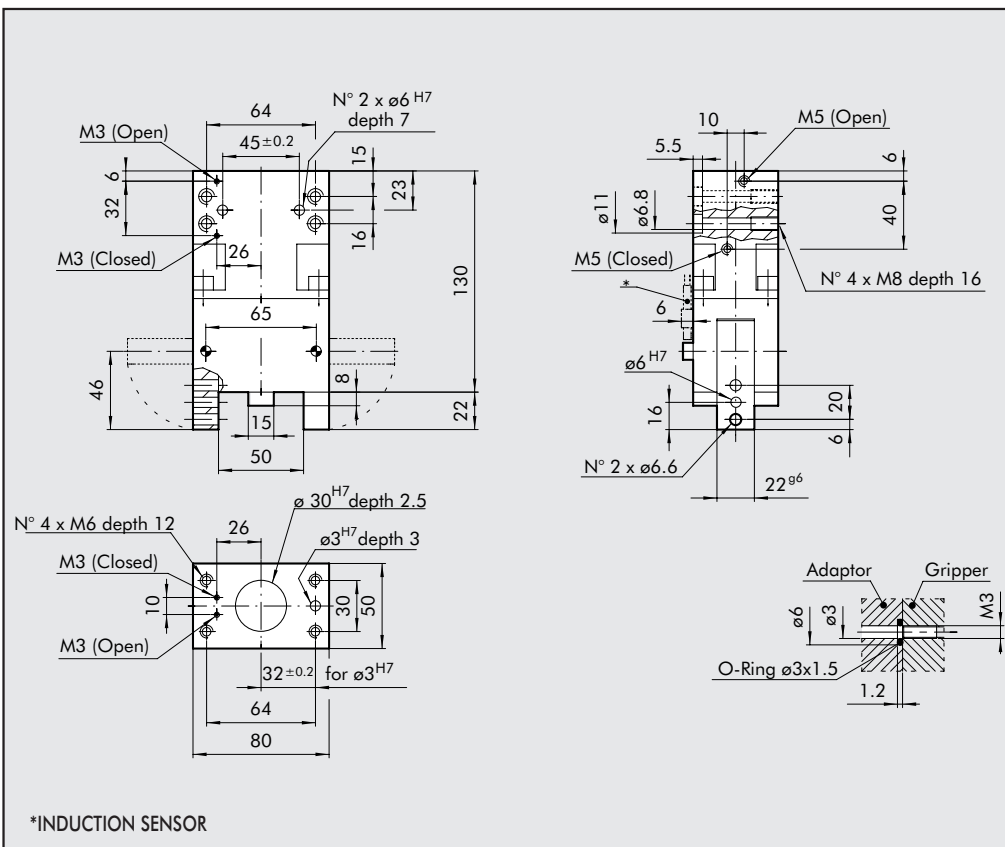

### ORDERING CODES

Code	Description
W1590800201	TOGGLE GRIPPERS P10-80

