



# TECHNOPOLYMER HINGED GRIPPERS SERIES P8

1

Single-acting hinged grippers, normally open, made entirely of technopolymer. Three sizes with clamping force 25-80 N at 6 bar.

This solution makes the entire system lighter. This gripper is corrosion-resistant and antimagnetic. It comes complete with spring-loaded bracket for pre-loading the piece (force 1.5-6 N) and sensor holders.



TECHNICAL FEATURES		P8 - 32	P8 - 40	P8 - 50
Pressure range	bar	4 to 7		
Temperature range	°C	5°C to 60°C		
Fluid		20µm dried or lubricated filtered air		
Life		over 2 million cycles		
Jaw opening angle		8°	8°	8°
Clamping force per jaw at 6 bar	N	22.5	48	80
Applicable weight (recommended)	kg	0.2	0.4	0.8
Air consumption per cycle	cm <sup>3</sup>	0.5	1	1.8
Opening time	sec	0.04	0.05	0.05
Closing time	sec	0.06	0.08	0.08
Weight of grippers	g	36	45	60
Moment of inertia	kg cm <sup>2</sup>	0.04	0.12	0.15
Repeatability	mm	0.1	0.1	0.1

## TABLE OF MOMENTS

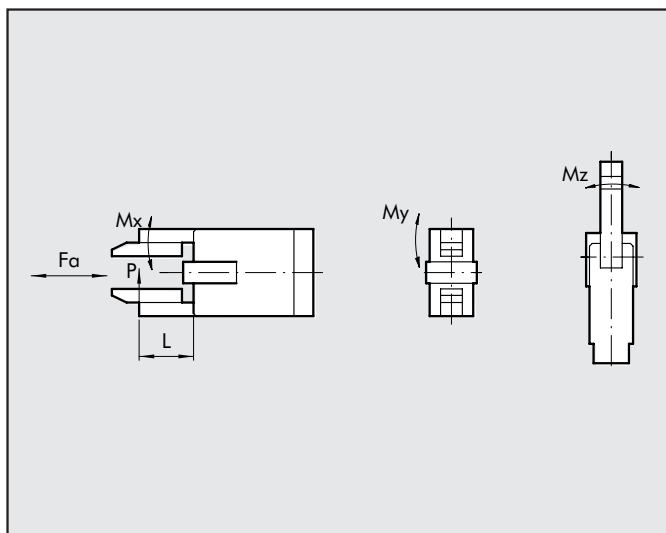

Gripper	FA (N)	Mx (Ncm)	My (Ncm)	Mz (Ncm)	P (N)
P8 - 32	3	9	10	10	22.5
P8 - 40	5	23	20	20	47.5
P8 - 50	8	49	30	40	80

### DIMENSIONS OF GRIPPERS P8-32

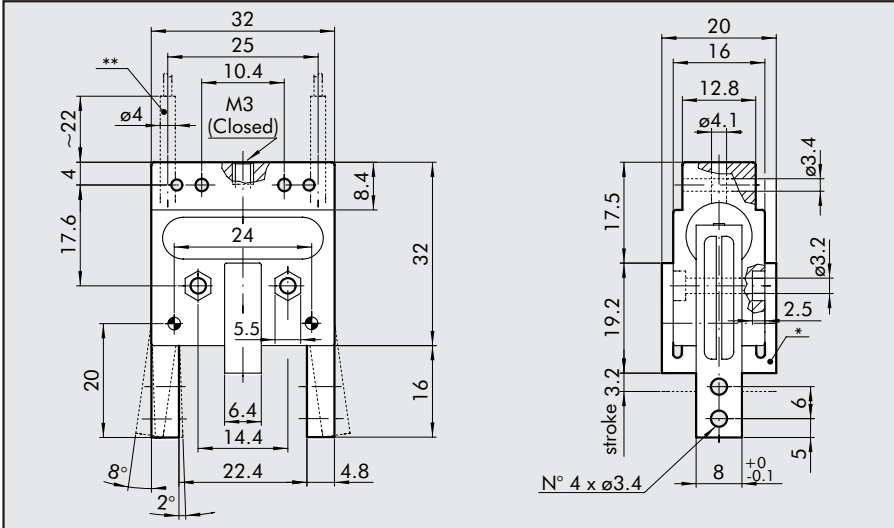

### ORDERING CODES

Code	Description
W0710010002	TECNOPOLIMER HINGED GRIPPERS P8-32

- \* Removable part clamping system
- \*\* Induction sensor

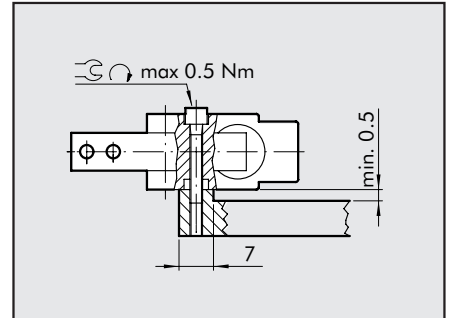

### DIMENSIONS OF GRIPPERS P8-40

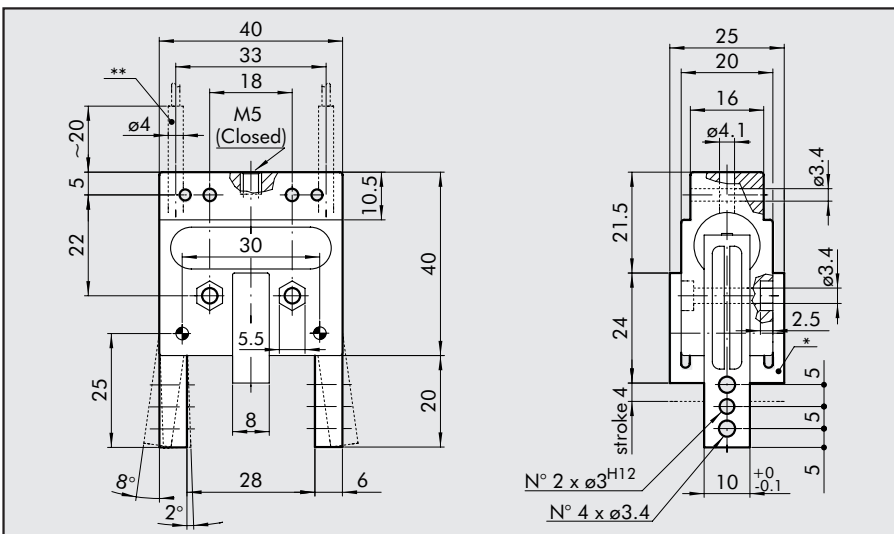

### ORDERING CODES

Code	Description
W0710010003	TECNOPOLIMER HINGED GRIPPERS P8-40

- \* Removable part clamping system
- \*\* Induction sensor

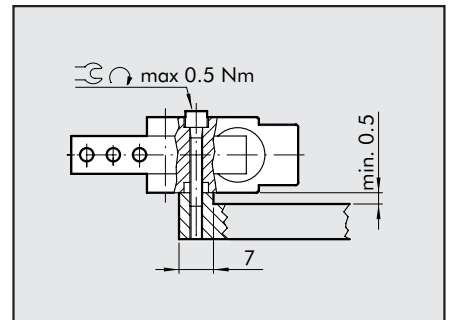

### DIMENSIONS OF GRIPPERS P8-50

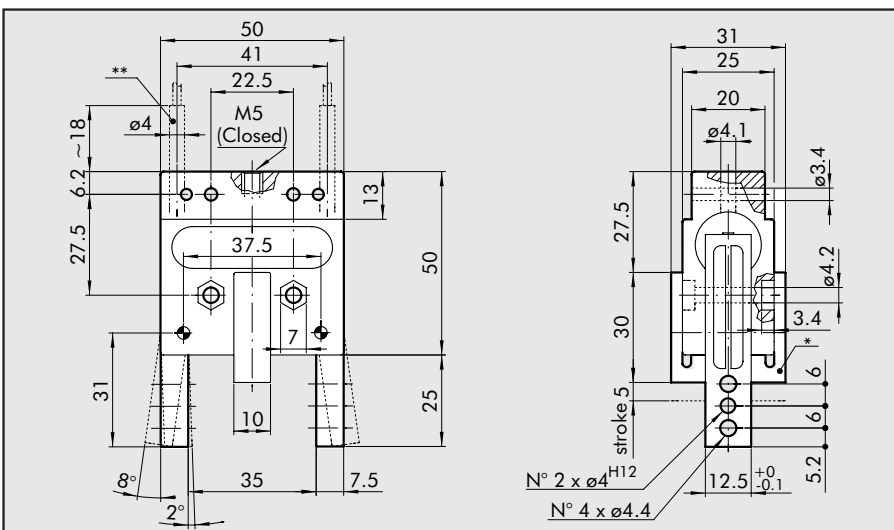

### ORDERING CODES

Code	Descrizione
W0710010004	TECNOPOLIMER HINGED GRIPPERS P8-50

- \* Removable part clamping system
- \*\* Induction sensor

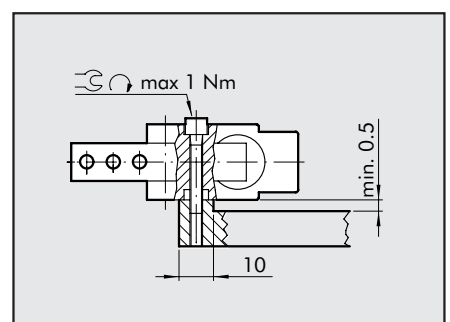

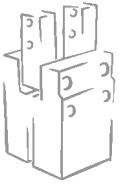

## INDUCTION SENSOR

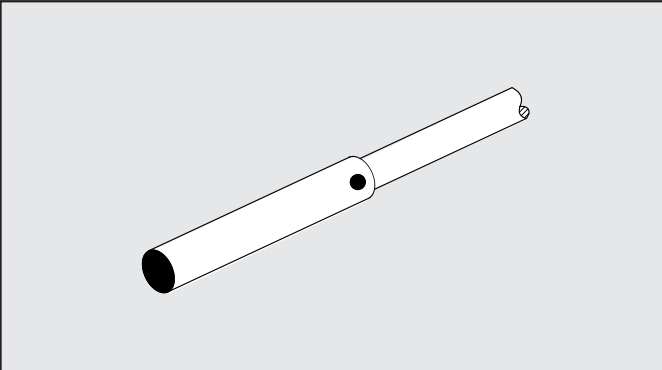

## ORDERING CODES

Code	Description
W0950037391	INDUCTION SENSOR Ø 4 mm PNP-NO-2 m

## NOTES

Area for notes, consisting of multiple horizontal lines for text entry.