



GRIPPER WITH 2 PARALLEL JAWS SERIES P3

1

These are grippers with 2 parallel double-acting jaws with internal and external clamping. The grippers are guaranteed for a minimum operation of 1.5 million cycles. Body made of hardened aluminium alloy, jaws made of ground, hardened and tempered steel.

Air can be supplied from below or from the side. Various types of fixing are available. The supply includes sensor holders (if necessary), fixing screws for all directions and O-rings for direct pneumatic connection.

(the inductive sensors are not supplied by Metal Work)



TECHNICAL FEATURES		P3 - 50	P3 - 64	P3 - 80	P3 - 100	P3 - 125
Pressure range	bar	2 to 8				
Temperature range	°C	5°C to 85°C				
Fluid		20µm dried or lubricated filtered air. Lubrication, if used, must be continuous				
Life		over 1.5 million cycles				
Jaw force	mm	4	6	8	10	6
Clamping force per jaw at 6 bar	N	50 (L=20mm)	110 (L=20mm)	180 (L=25mm)	225 (L=32mm)	750 (L=32mm)
Applicable weight (recommended)	Kg	0.5	1.2	1.8	2.8	8.5
Air consumption per cycle	cm ³	5	10	20	40	70
Opening time	sec	0.02	0.02	0.03	0.05	0.08
Closing time	sec	0.02	0.02	0.03	0.05	0.08
Weight of grippers	Kg	0.125	0.27	0.43	0.75	1.3
Moment of inertia	Kg cm ²	0.5	1.2	2	10	21
Repeatability	mm	0.01	0.01	0.01	0.01	0.02
Maximum length of clamping fingers	mm	50	64	80	100	125

CLAMPING FORCE ACCORDING TO FINGER LENGTH

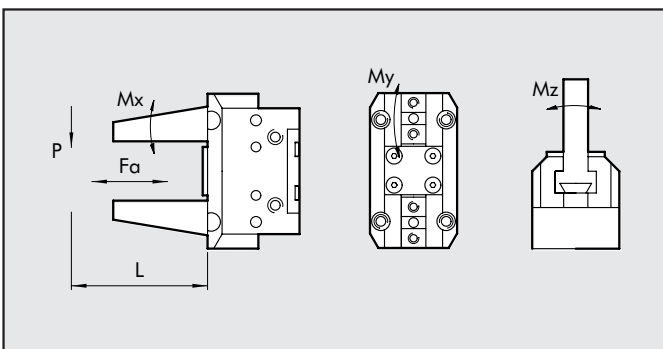

GRIPPER	FΔ (N)	Mx (Nm)	My (Nm)	Mz (Nm)	L (mm)	P (N)
P3 - 50	250	10	10	12	20	50
P3 - 64	450	30	25	15	20	110
P3 - 80	600	90	35	30	25	180
P3 - 100	800	95	45	45	32	225
P3 - 125	900	100	70	60	32	750

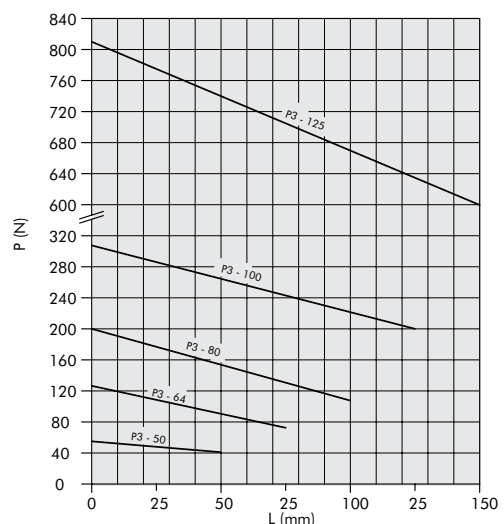

DIMENSIONS OF GRIPPERS P3-50

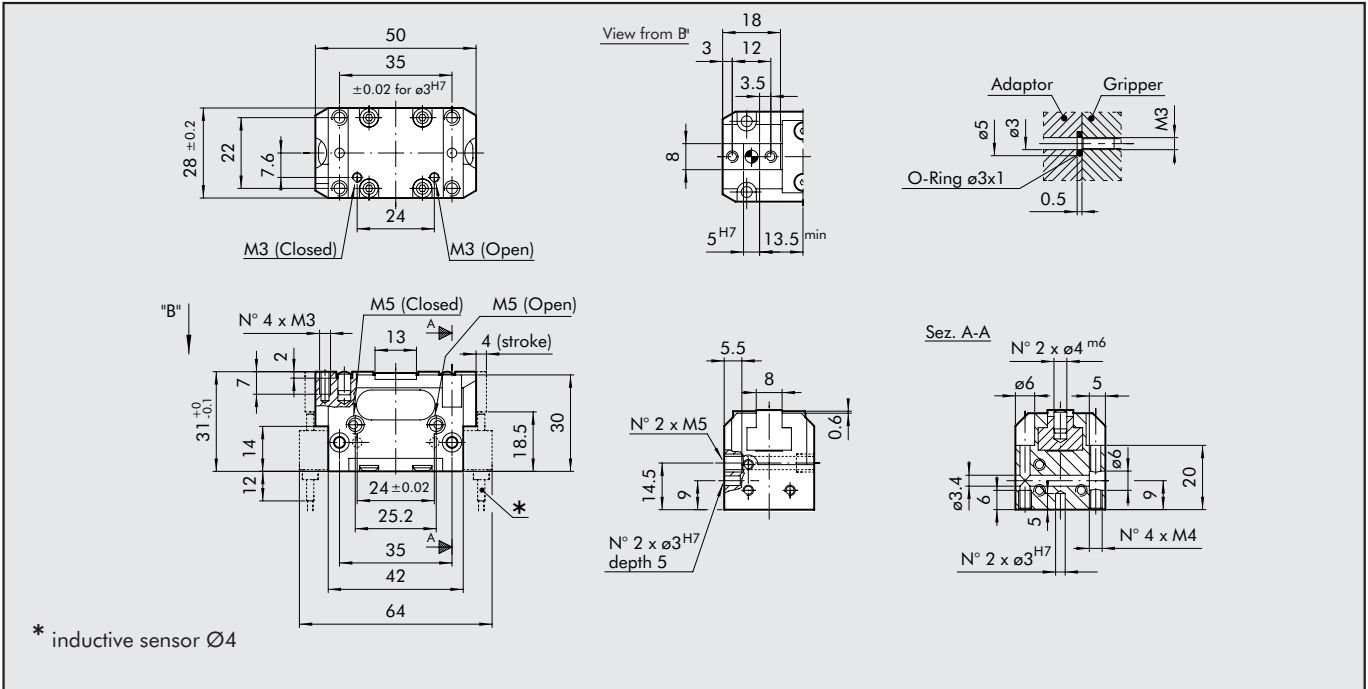

ORDERING CODES

Code	Description
W1560500200	GRIPPER WITH 2 PARALLEL JAWS P3-50

DIMENSIONS OF GRIPPERS P3-64

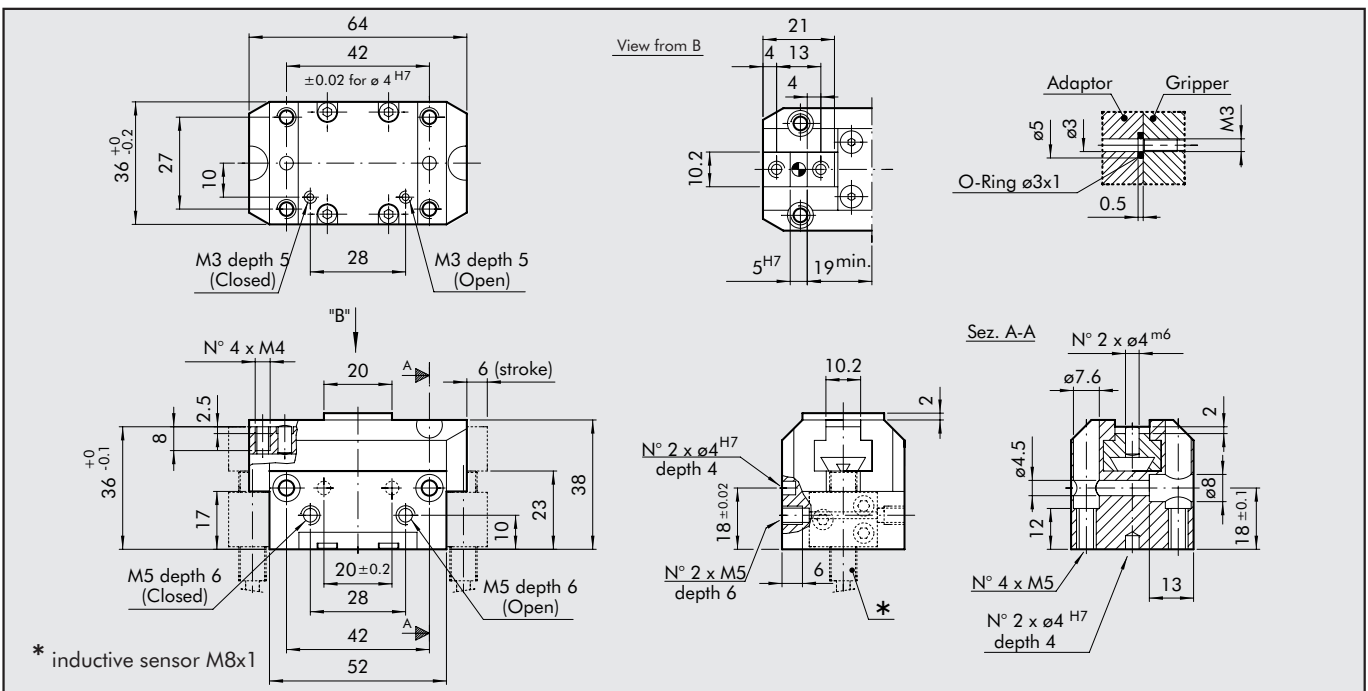

ORDERING CODES

Code	Description
W1560640200	GRIPPER WITH 2 PARALLEL JAWS P3-64



DIMENSIONS OF GRIPPERS P3-80

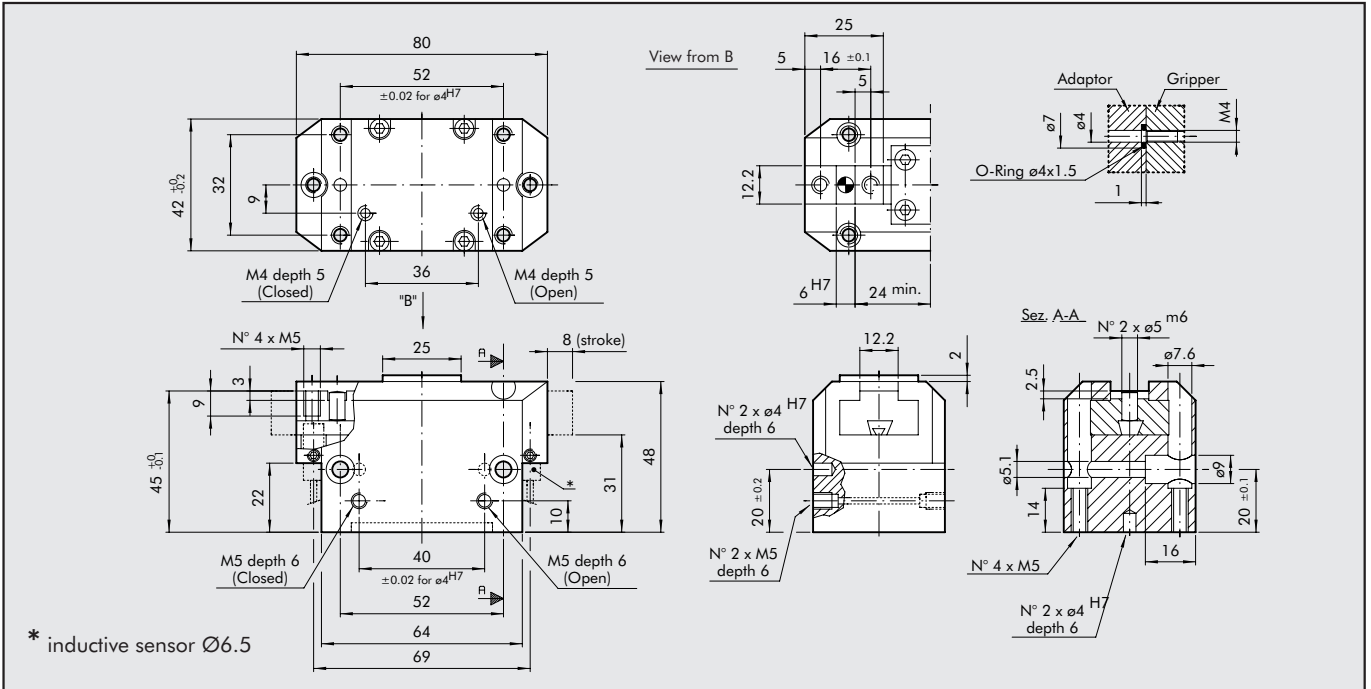

ORDERING CODES

Code	Description
W1560800200	GRIPPER WITH 2 PARALLEL JAWS P3-80

DIMENSIONS OF GRIPPERS P3-100

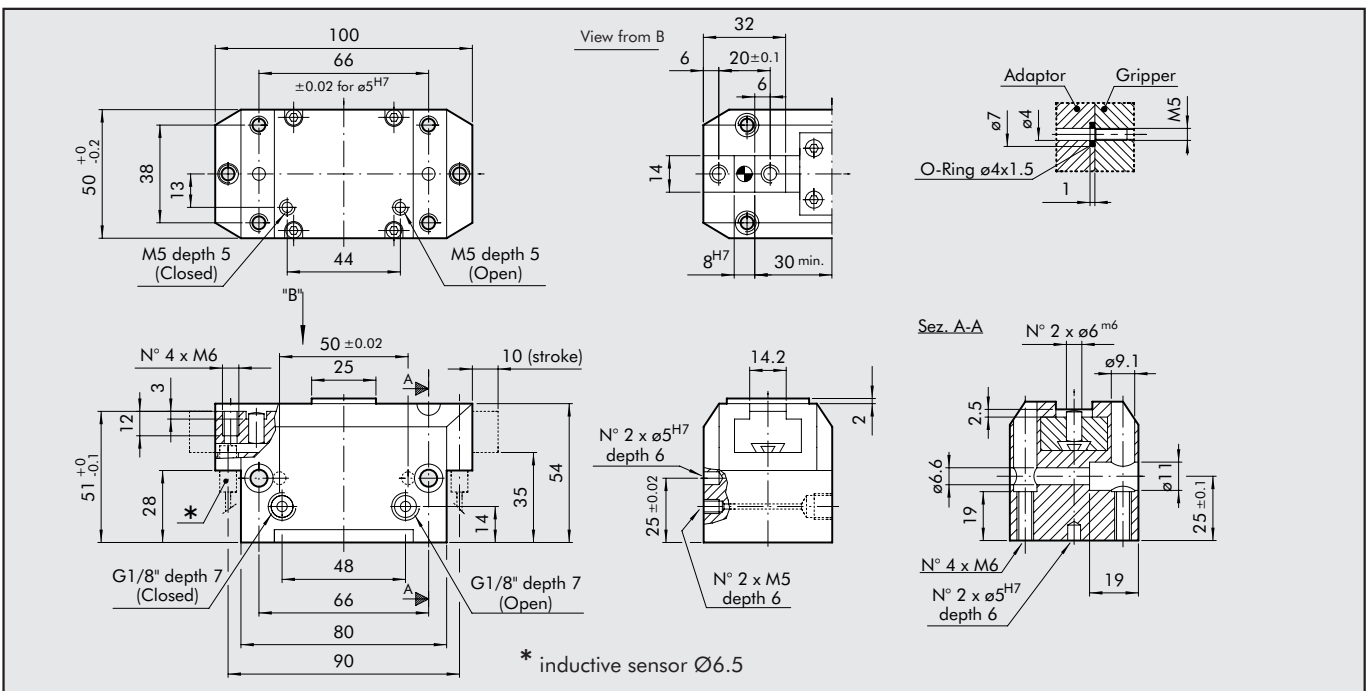

ORDERING CODES

Code	Description
W1561000200	GRIPPER WITH 2 PARALLEL JAWS P3-100

