

DIAPHRAGM DRIER SERIES DRY 100 Skillair®

Skillair® diaphragm driers are used to reduce the air's moisture content by lowering the dew point, i.e. the temperature at which condensate starts to form. They use diaphragms with a new cross-fibre system that guarantees a lower consumption of regenerated air and hence power. This is an all-in-one unit complete with a filter, purifier, air intake and drier. The air intake uses air that has been filtered and purified, but not dried, and sends it to utilities not requiring dry air. This is a much more efficient system as only the required quantity of compressed air is dried. An alternative proposal is the drier by itself. As the Skillair® system is modular, it can be inserted in any type of assembly. It is important, however, to remember that only properly filtered and purified air must be supplied to the drier. It's advisable that the drier should be used at the highest pressure as possible



TECHNICAL DATA	DRY 100	FIL+DEP+PA+DRY 100
Threaded port	G 1/4" - G 3/8"	
Max input pressure	1,3 MPa / 13 bar /188 psi	
Suggested flow rate at 6,3 bar (0,63 MPa, 91 psi)	Nl/min scfm	230 8
Fluid	Compressed air without condensate max solid particle size: 1µm max oil residue: 0,01mg/m ³	Compressed air
Consumption of compressed air for regeneration at 6,3 bar	Nl/min scfm	20 0,7
Minimum temperature	2°C / 35°F	
Maximum temperature at 1MPa; 10 bar; 145 psi	50°C / 122°F	
Noise level	dB(A) <45	
Weight	Kg 0,84	1,24
Wall-mounting screws	M4 x 50	
Mounting position	In ogni posizione	Verticale
Condensate drain		Manual semiautomatic (RMSA) Automatic, vacuum (SAC)
Filter bowl and purification bowl capacity	cm ³	22
Important note	The drier must always be preceded by a 5 µm filter and a purifier	

COMPONENTS

- ① Body: painted anodized aluminium
- ② Diaphragm: poliestere sulfone resin
- ③ Inner tube: salt-water resistant aluminium
- ④ O-Ring seals: NBR
- ⑤ Adapter: anodized aluminium
- ⑥ Flanges: brass
- ⑦ Skillair® body: technopolymer

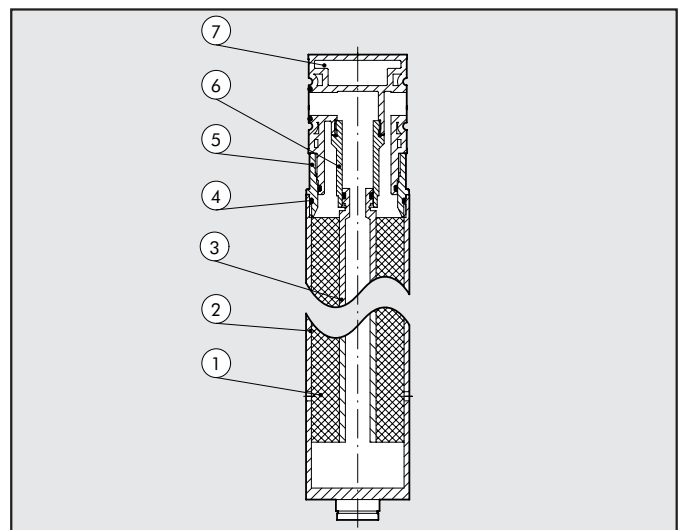

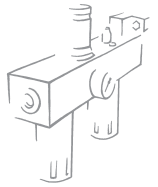

OPERATING PRINCIPLE

The drying element is comprised of cross-fibre diaphragms arranged around an inner tube. The compressed air passes through the tube (A) and flows back through the hollow diaphragms (B). At the same time, the regeneration air required for drying is tapped from the outlet port, expands as it passes through a nozzle (C), which reduces the relative humidity, and flows back along the outer side of the fibres. This allows moist compressed air to flow through the diaphragms and the dry regeneration air outside. The difference in moisture content causes the water to pass from the compressed air to the regeneration air, which is drained through holes (D) at the bottom of the drier.

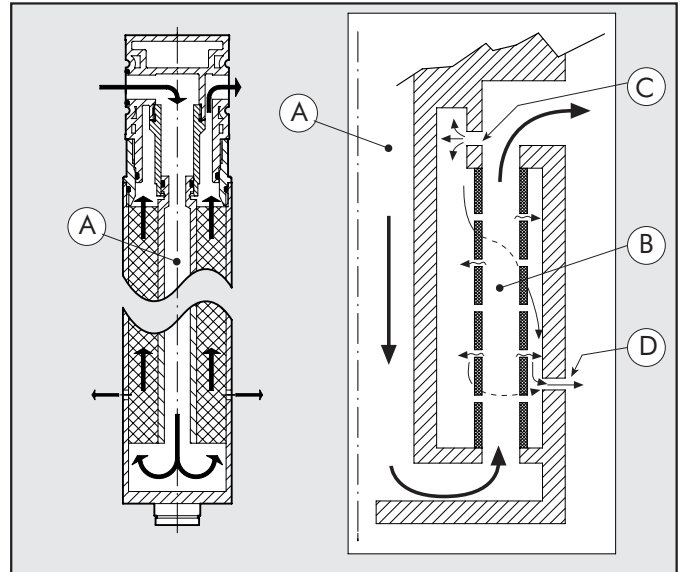

ADVANTAGES

- Drying is guaranteed as all the moisture is removed
- Minimum consumption of regeneration air
- Reduce drier maintenance as none of the components are subject to wear
- Environmentally friendly drying process.

FLOW CHARTS

DRY 100

$$\Delta P = (P_m - P_v)$$

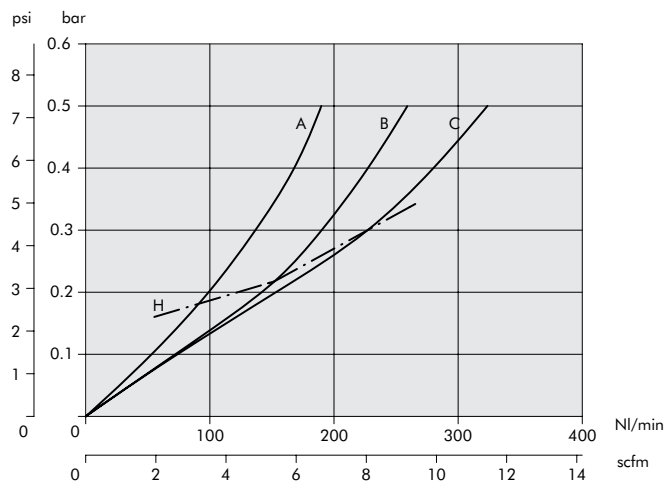

A = 2.5 bar
B = 4 bar
C = 6.3 bar

FIL (5μm)+DEP+PA+DRY 100

$$\Delta P = (P_m - P_v)$$

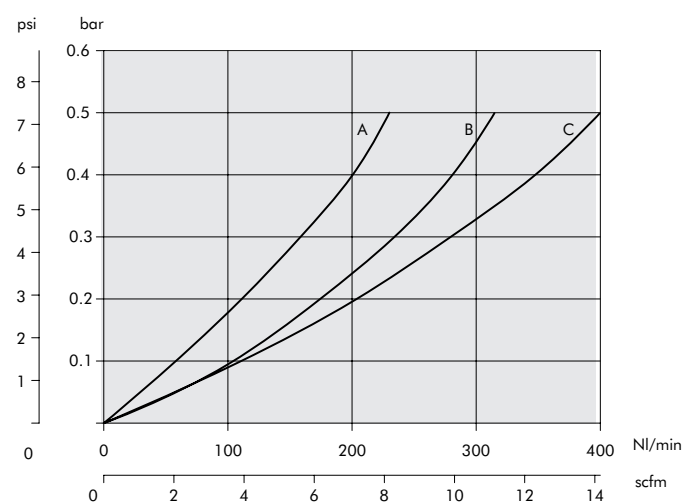

Flow rate

DRYING

Dew point of the outgoing air in nominal reference conditions:

- Dew point referred to atmospheric pressure
- Incoming air with dew point at 25°C (i.e. saturated at 25°C)
- Inlet pressure 7 bar (0,7 MPa)

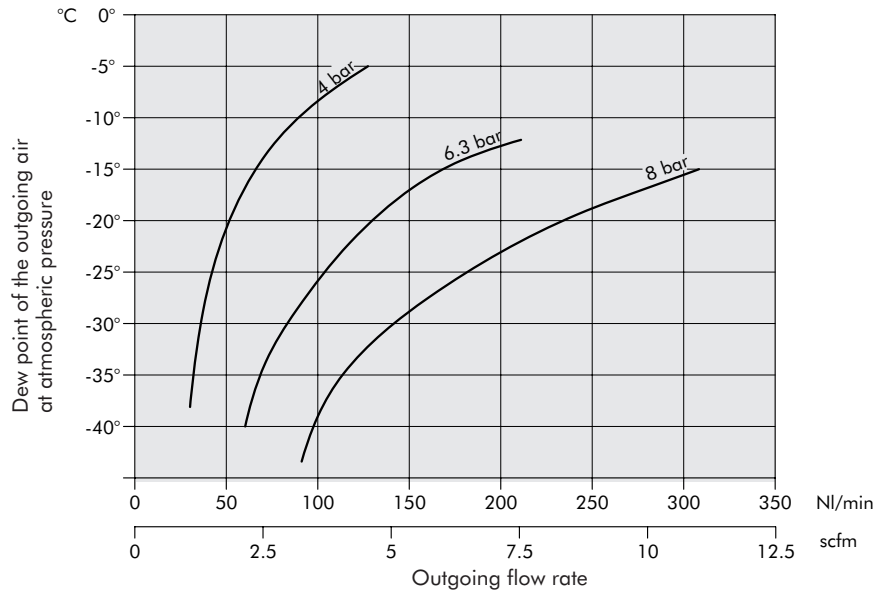

In the diagram below is indicated the dew point of the outgoing compressed air for various input air dew points, depending on the rate of flow of compressed air.

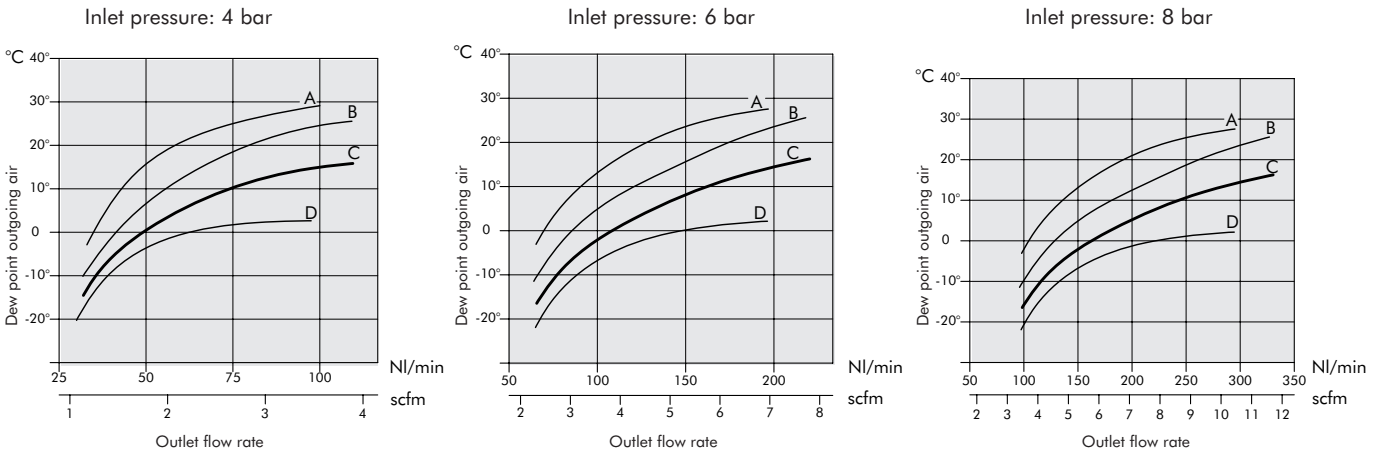

A : Incoming air with dew point at 45°C
 B : Incoming air with dew point at 35°C

C : Incoming air with dew point at 25°C
 D : Incoming air with dew point at 15°C

REGENERATION AIR

Thanks to the cross-fiber system, the flow rate loss is much lesser than in traditional linear-fibre systems. In the diagram on the right is indicated the drop-in air flow according to the operating pressure

Notice: for the best drying efficiency the highest pressure possible is required, though this implies an increase of the regeneration air.

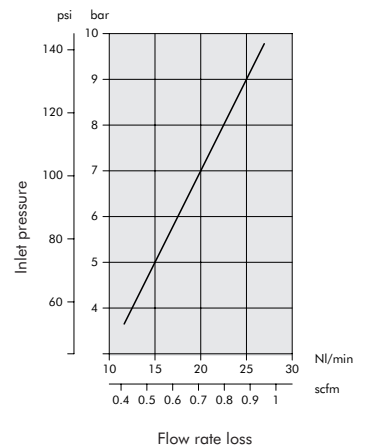

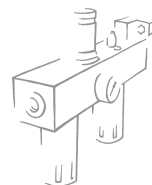

DRY 100 DIMENSIONS

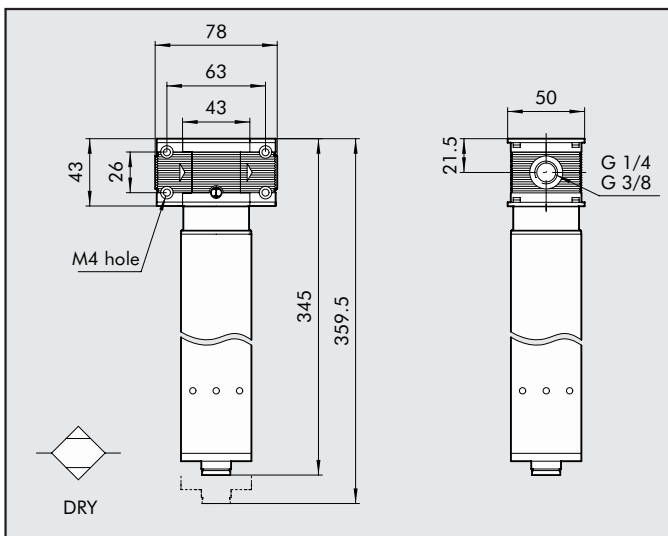

ORDERING CODES

Cod.	Description
3290001A	DRY 100 WITHOUT END PLATES
3290001	DRY 100 1/4"
3390001	DRY 100 3/8"

FIL+DEP+PA+DRY 100 DIMENSIONS

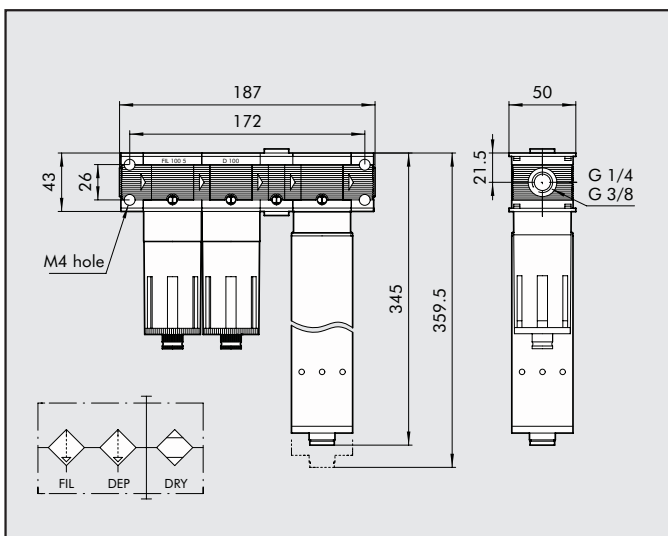

ORDERING CODES

Cod.	Description
3291001	F+D+PA+DRY 100 1/4" RMSA-RMSA
3291005	F+D+PA+DRY 100 1/4" SAC-RMSA
3291006	F+D+PA+DRY 100 1/4" SAC-SAC
3391001	F+D+PA+DRY 100 3/8" RMSA-RMSA
3391005	F+D+PA+DRY 100 3/8" SAC-RMSA
3391006	F+D+PA+DRY 100 3/8" SAC-SAC

NOTES