

Skillair® PILOT REGULATOR

The pilot regulator is used when great accuracy is required in maintaining the set pressure under changing operating conditions.

It is ideal for use as:

- a precision regulator for flow rates < 100 NI/min.
- a pilot in general – typically for large size regulators (see REG 400)

The system's high operating accuracy and low hysteresis are determined by the virtually total lack of friction. The presence of a slight air leak is necessary for the regulator to operate properly – it is not a malfunction. It is advisable to use filtered air.



TECHNICAL DATA		PILOT REGULATOR	
Threaded port		G 1/4"	
Setting range	bar	0÷2 - 0÷4 - 0÷8 - 0÷12	
Max. input pressure	MPa	1.3	
	bar	13	
	psi	188	
Flow rate at 6.3 bar (0.63 MPa-91 psi) ΔP 0.5 bar (0.05 MPa – 7 psi)		120 NI/min - 4,3 scfm	
Flow rate at 6.3 bar (0.63 MPa-91 psi) ΔP 1 bar (0.1 MPa – 14 psi)		140 NI/min - 5 scfm	
Fluid		Filtered, lubricated or unlubricated compressed air. Lubrication, if used, must be continuous.	
Max temperature at 1 MPa; 10 bar; 145 psi	°C	50	
	°F	122	
Weight	Kg	0.6	
Mounting		In any position	
Pressure gauge port		G 1/8"	
Notes on use		The regulator pressure must always be set upwards. For increased sensitivity, use a pressure regulator with a rated pressure as close as possible to the required value. Do not take air from the pressure gauge ports. Mount directly on REG 400.	

3

COMPONENTS

- ① Aluminium body
- ② Technopolymer knob
- ③ OT58 brass adjusting screw
- ④ OT58 brass scroll
- ⑤ Technopolymer bell
- ⑥ Technopolymer ring nut
- ⑦ Steel adjusting spring
- ⑧ Rolling diaphragm
- ⑨ NBR relieving gaskets
- ⑩ OT58 brass stem
- ⑪ Stainless steel ball valve
- ⑫ Stainless steel valve spring
- ⑬ NBR gaskets

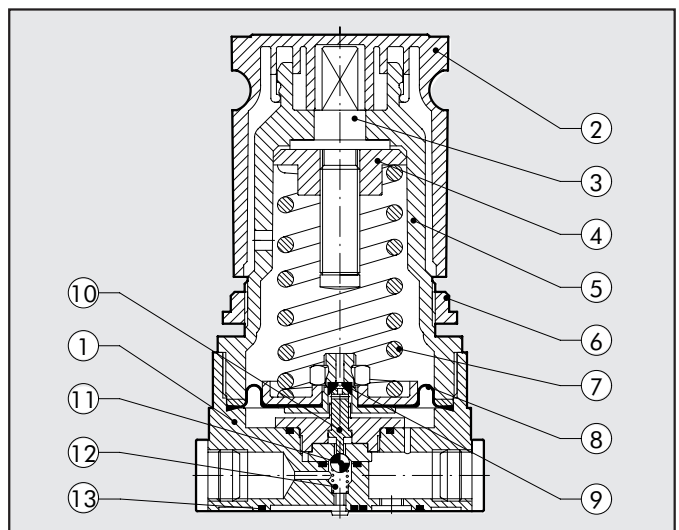

FLOW CHARTS

FLOW FEATURES REG. P 1/4''

Preset pressure
Pm = 7 bar = 0,7 MPa = 100 psi

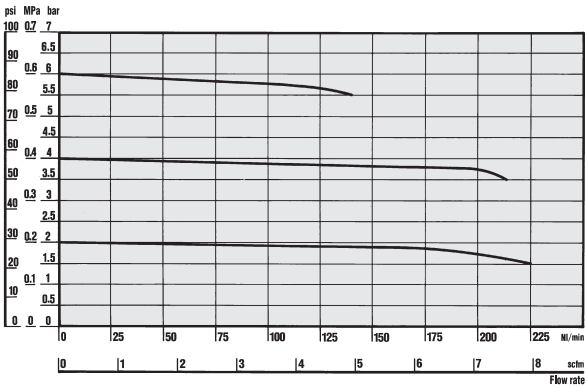

REGULATION FEATURES REG. P 1/4'' *

Flow: A = 0 Nl/min = 0 scfm
B = 25 Nl/min = 0,88 scfm - C = 50 Nl/min = 1,76 scfm

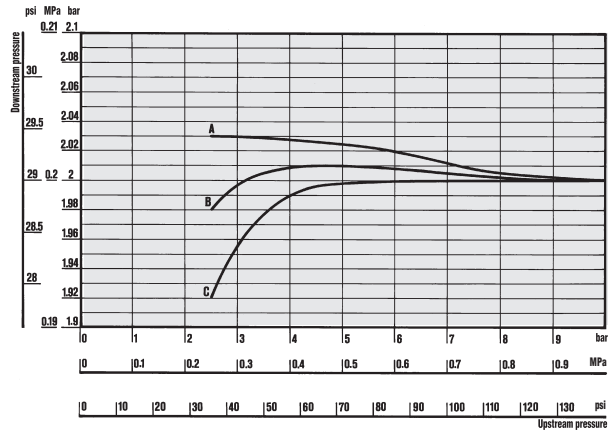

REGULATION FEATURES REG. P 1/4'' *

Flow: A = 0 Nl/min = 0 scfm
B = 25 Nl/min = 0,88 scfm - C = 50 Nl/min = 1,76 scfm

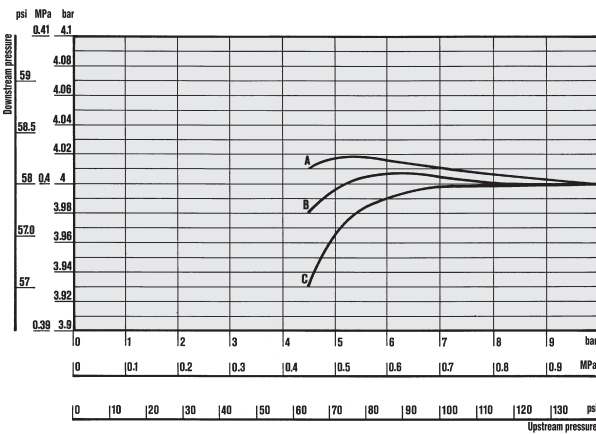

REGULATION FEATURES REG. P 1/4'' *

Flow: A = 0 Nl/min = 0 scfm
B = 25 Nl/min = 0,88 scfm - C = 50 Nl/min = 1,76 scfm

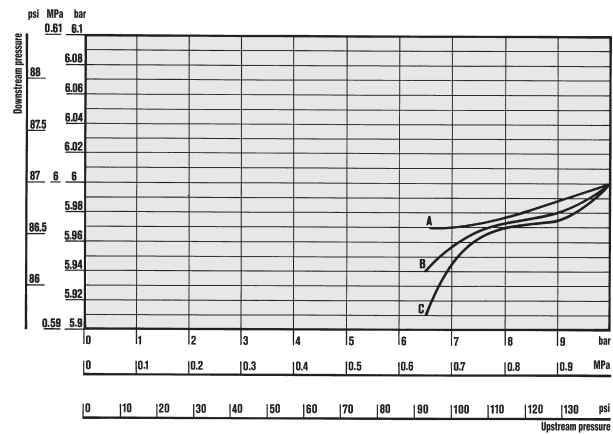

Department of Mechanics
Turin Polytechnic

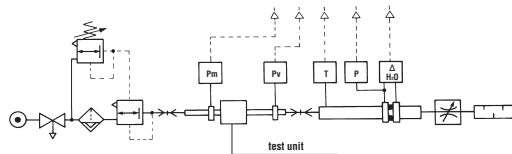

● Flow tests carried out at the Department of Mechanics, Turin Polytechnic, using the computerized test bench following CETOP RP50R recommendations (ISO DIS 6358-2-approved) with ISO 5167 diaphragm gauge.

* Pressure stability adjusted according to changes in upstream pressure.

DIMENSIONS

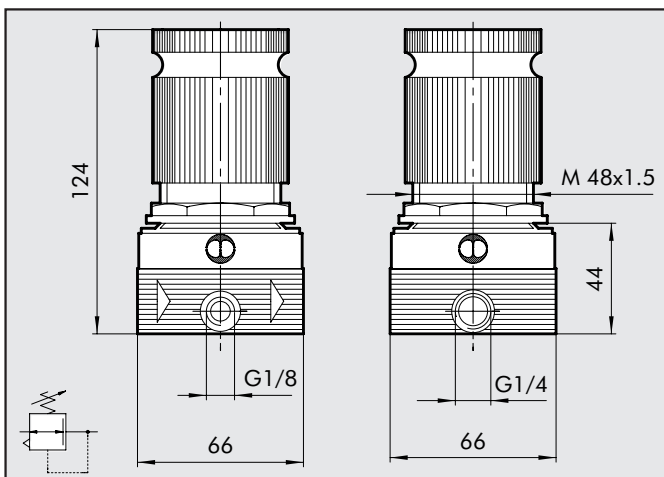

ORDERING CODES

Code	Description
3206001	REG. P 1/4'' 02
3206002	REG. P 1/4'' 04
3206003	REG. P 1/4'' 08
3206004	REG. P 1/4'' 012