

Skillair® REGULATORS

Each system served by the air supply mains (e.g. actuators and general appliances) requires its own constant operating pressure. It is necessary to use a regulator to regulate the pressure within a set range by means of regulating springs, with the pressure never exceeding the mains pressure. The new Skillair regulator uses a rolling diaphragm which gives a much better performance than the flat version.

Advantages of this system:

- Increased stroke, increased valve opening and hence higher flow rate.
- Decreased dynamic and inrush friction; prompt, more sensitive operation.
- Reduced working stress and hence longer life allowing the use of thinner diaphragms (0.45 mm versus 1.5 mm for a flat one) which increases regulator sensitivity and prompt action.
- Increased accuracy in maintaining the set pressure with both variable flow rates and different feed pressures.
- Downstream overpressures relieved quickly.



TECHNICAL DATA	REG 100	REG 100	REG 200	REG 200	REG 200	REG 300	REG 300	REG 300
Threaded port	G 1/4"	G 3/8"	G 1/4"	G 3/8"	G 1/2"	G 1/2"	G 3/4"	G 1"
Setting range	0÷2 - 0÷4 - 0÷8 - 0÷12		0÷2 - 0÷4 - 0÷8 - 0÷12			0÷2 - 0÷4 - 0÷8 - 0÷12		
Max. input pressure	1.5		1.3			1.3		
	bar		bar			bar		
	217		188			188		
	psi		psi			psi		
Flow rate at 6.3 bar (0.63 MPa-91 psi)	1100		2500			3500		
ΔP 0.5 bar (0.05 MPa - 7 psi)	39		88			124		
Flow rate at 6.3 bar (0.63 MPa-91 psi)	1600		3500			7000		
ΔP 1 bar (0.1 MPa - 14 psi)	57		124			247		
Fluid	Filtered lubricated or unlubricated compressed air. Lubrication, if used, must be continuous.							
Max temperature at 1 MPa; 10 bar; 145 psi	50		50			50		
	°C		°C			°C		
	122		122			122		
	°F		°F			°F		
Weight	0.4		0.7			1.4		
	Kg		Kg			Kg		
Wall fixing screws	M4x50		M5x60			M5x70		
Mounting	In any position							
Pressure gauge port	G 1/8"							
Notes on use	The regulator pressure must always be set upwards. For increased sensitivity, use a pressure regulator with a rated pressure as close as possible to the required value. Do not take air from pressure gauge ports.							

COMPONENTS

- ① Technopolymer body
- ② Zamak end plate
- ③ Technopolymer knob
- ④ Technopolymer bell
- ⑤ OT58 brass adjusting screw
- ⑥ OT58 brass scroll
- ⑦ Steel adjusting spring
- ⑧ Technopolymer ring nut
- ⑨ Rolling diaphragm
- ⑩ NBR relieving gaskets
- ⑪ OT58 brass stem
- ⑫ Valve with NBR vulcanized gasket
- ⑬ Stainless steel valve spring
- ⑭ Technopolymer plug
- ⑮ NBR gaskets

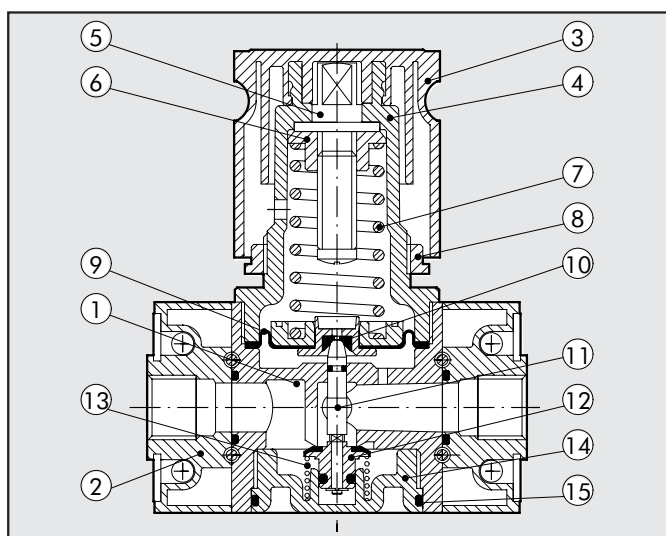

FLOW CHARTS

REG 100 1/4 - 3/8

Preset pressure
Pm = 7 bar - 0.7 MPa - 100 psi

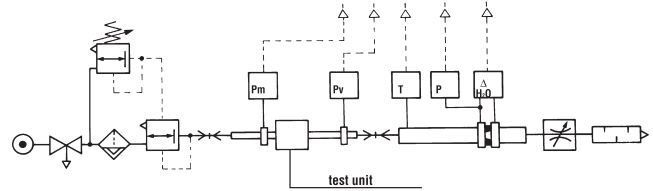
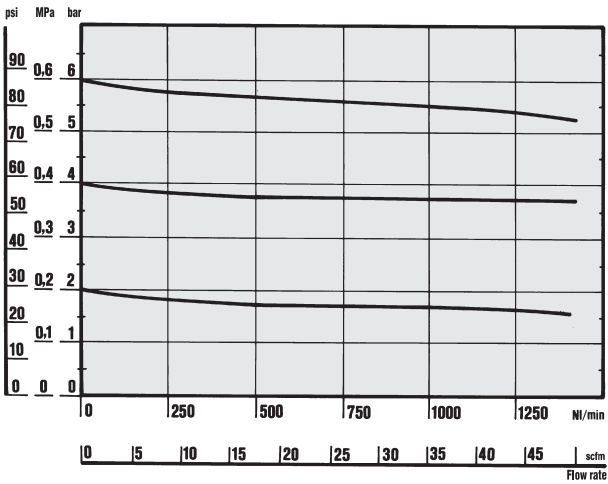

• Flow tests carried out at the Department of Mechanics, Turin Polytechnic, using the computerized test bench following CETOP RP50R recommendations (ISO DIS 6358-2-approved) with ISO 5167 diaphragm gauge.

REG 200 1/4 - 3/8 - 1/2

Preset pressure
Pm = 7 bar - 0.7 MPa - 100 psi

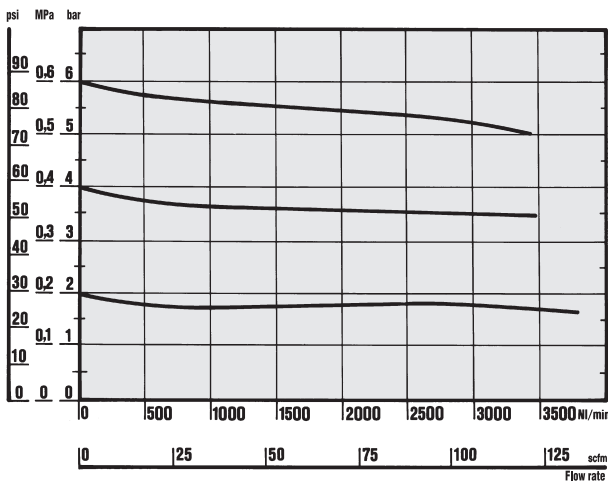

REG 300 1/2 - 3/4 - 1

Preset pressure
Pm = 7 bar - 0.7 MPa - 100 psi

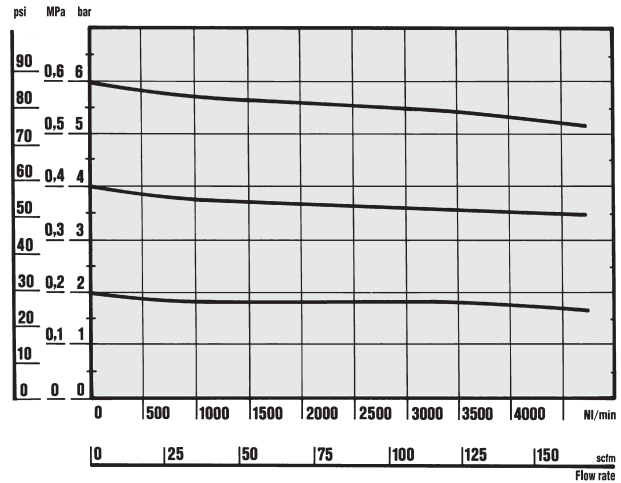

DIMENSIONS

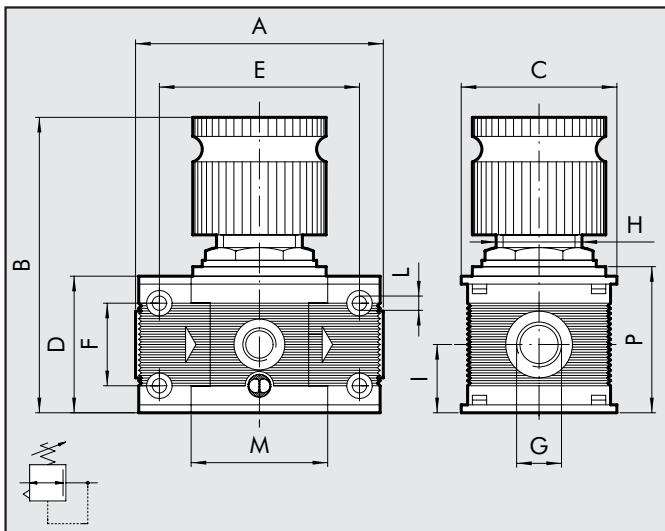

	REG 100	REG 100	REG 200	REG 200	REG 200	REG 300	REG 300	REG 300
	G 1/4	G 3/8	G 1/4	G 3/8	G 1/2	G 1/2	G 3/4	G 1"
A	78			93.5		110		112
B	98			125			148	
C	50		63				72	
D	43		55				65	
E	63		78.5				92	
F	26		36				42	
G	G 1/4	G 3/8	G 1/4	G 3/8	G 1/2	G 1/2	G 3/4	G 1"
H	30x1.5		40x1.5				48x1.5	
I	21.5		27.5				32.5	
L	M4 hole		M5 hole				M5 hole	
M	43		55.5				65	
P	46		58				69	

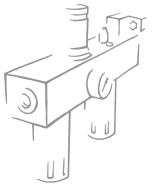

Skillair® 400 REGULATOR

TECHNICAL DATA	REG 400	REG 400	REG 400	REG 400
Threaded port	G 1"	G 1"1/4	G 1"1/2	G 2"
Setting range	Depending on the pilot operated regulator			
Max. input pressure	MPa	1.3		
	bar	13		
	psi	188		
Flow rate at 6.3 bar (0.63 MPa-91 psi) NI/min		18000		20000
ΔP 0.5 bar (0.05 MPa - 7 psi)	scfm	363		707
Fluid	Filtered, lubricated or unlubricated compressed air. Lubrication, if used, must be continuous.			
Max temperature	°C	50		
at 1 MPa; 10 bar; 145 psi	°F	122		
Weight	Kg	4.8		5.6
Wall fixing screws	M6x110			
Mounting	In any position			
Pressure gauge port	G1/4"			
Notes on use: The regulator pressure must always be set upwards.				
Series 400 end plates come with a patented system with a rotary sliding end joint to allow the unit to be adapted to the pipe cutting distance.				

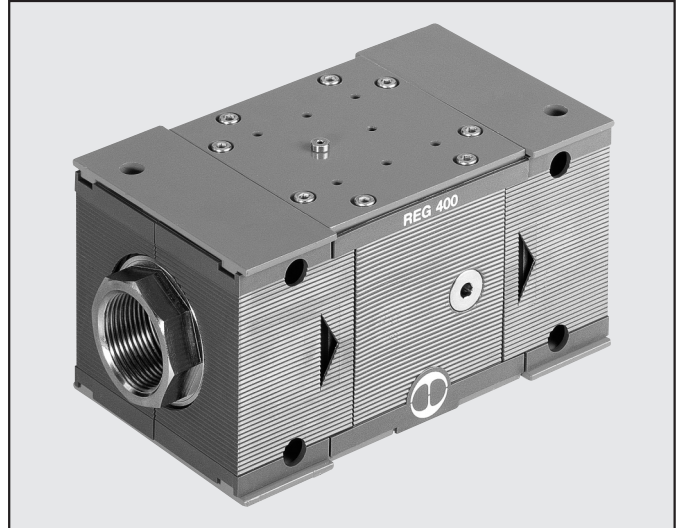

COMPONENTS

- ① Aluminium body
- ② Aluminium end plate
- ③ OT58 threaded bush, axial adjustment
- ④ OT58 brass retaining ring
- ⑤ Rolling diaphragm
- ⑥ OT58 brass plug
- ⑦ Stainless steel valve spring
- ⑧ OT58 brass stem with air relief hole
- ⑨ Valve with NBR vulcanized gasket
- ⑩ NBR gaskets.

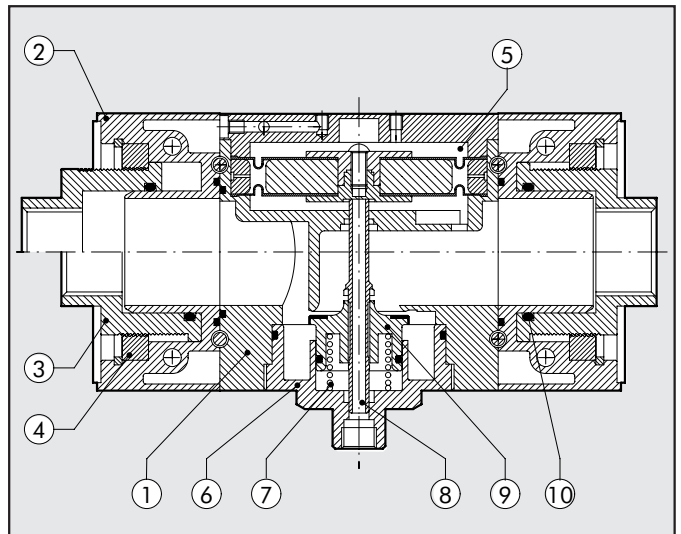

FLOW CHARTS

REG 400 1"

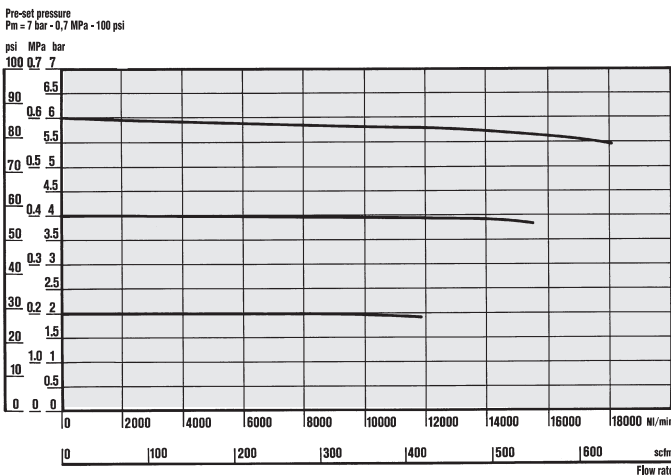

REG 400 2"

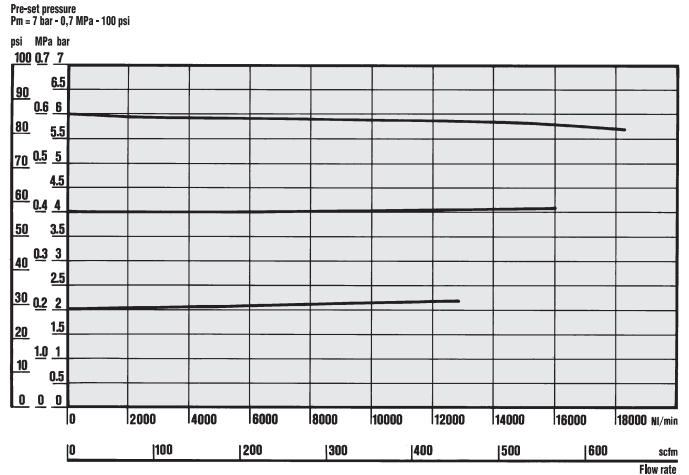

DIMENSIONS

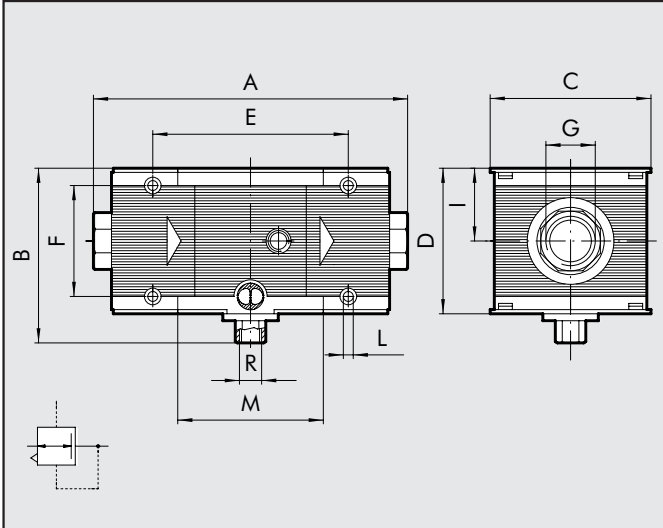

	REG 400	REG 400	REG 400	REG 400
Threaded port	G 1"	G 1"1/4	G 1"1/2	G 2"
A	225÷255		127	283÷313
B	116			
C	105			
D	141.4			
E	80			
F	G 1"	G 1"1/4	G 1"1/2	G 2"
G	52.5			
I	M6 hole			
L	105.4			
M	G 1/4			
P	G 1/4			
R				

INSTRUCTIONS FOR USE

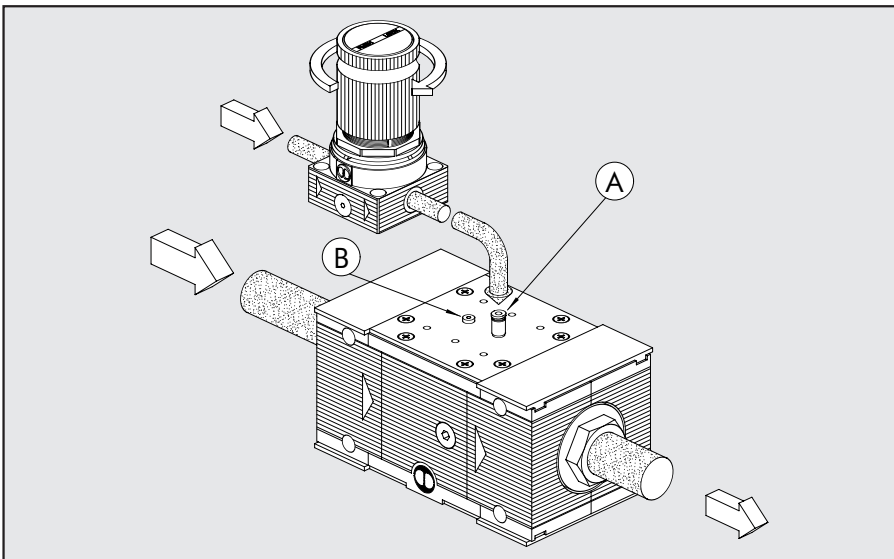

1 REMOTE PILOT

- Fit the A7 M5 plug into the threaded hole B (close to the entrance).
- Fit the M5 fitting into the threaded hole A as close to the entrance as possible.
- Connect the downstream circuit of the selected pilot operated regulator to the input A (R1 fitting).
- Set the required pressure on the pilot operated regulator.

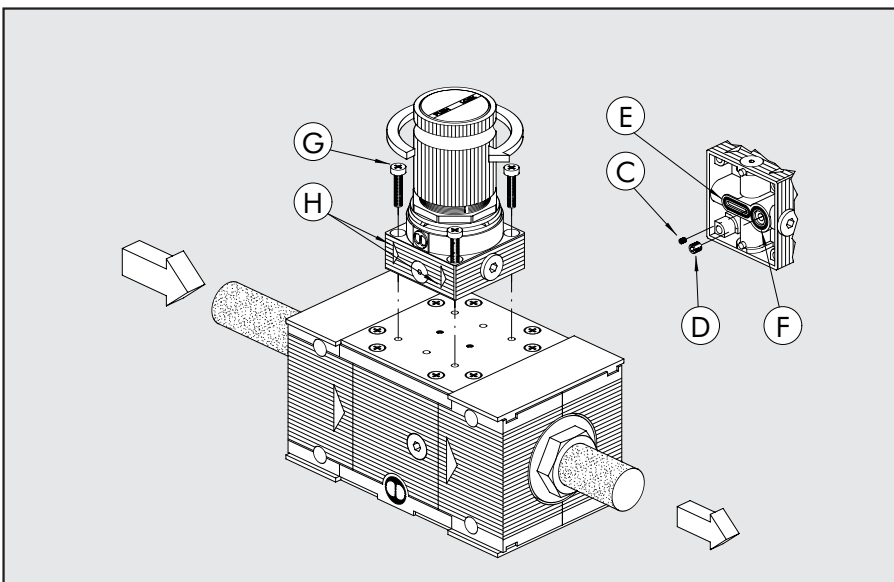

2 DIRECT PILOT WITH SKILLAIR PILOT OPERATED REGULATOR

- Remove the pins C and D under the pilot operated regulator.
- Check that the two gaskets E and F under the pilot are in place.
- Fix the pilot operated regulator to the base of the regulator using the self-threading screws G. Make sure the arrows H point in the same direction as the arrows in relief under the base of the regulator.

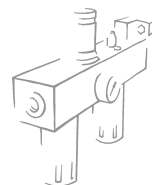

INSTRUCTIONS FOR USE

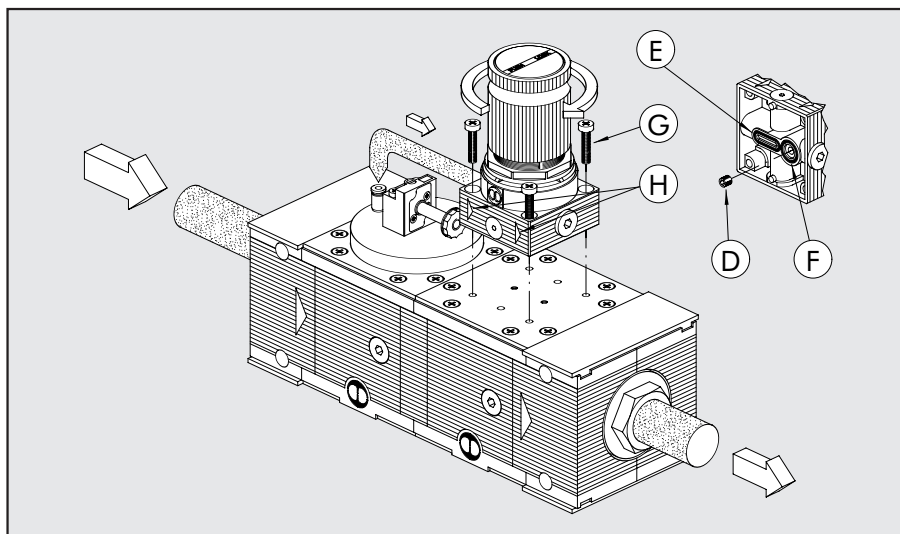

3 PILOT REGULATOR FOLLOW-UP LINK

This is used when the regulator is mounted downstream of a V3V valve or an APR. The air can be bled from the V3V or APR valves instead of from the regulator relieving system.

Remove only the stud pin marked with a letter D under the pilot regulator.

Check the two gaskets under the pilot marked E and F.

Secure the pilot regulator to the regulator base with the self-tapping screws marked with a letter G. Making sure the arrows marked H point in the same direction as the arrows in relief under the regulator base.

Remove the A7 M5 plug from the V3V or APR plate and remount the fitting.

Connect the pilot regulator supply to the fitting.

KEY TO CODES

REG	100	1/4	02
FILTER ELEMENT	SIZE	THREADED PORT	SETTING RANGE
REG	100	1/4	0 ÷ 2 bar
	200	3/8	0 ÷ 4 bar
	300	1/4	0 ÷ 8 bar
		3/8	0 ÷ 12 bar
	400	1/2	Depending on the pilot used
		3/4	
		1	
		1 1/4	
		1 1/2	
		2	

The pilot operated regulator is necessary for size 400.
See pag. 3.1/17.

3

ORDERING CODES

Code	Description	Code	Description	Code	Description
SKILLAIR 100 REGULATOR		SKILLAIR 200 REGULATOR		SKILLAIR 300 REGULATOR	
3202001A	REG 100 02 WITHOUT END PLATES	3402001A	REG 200 02 WITHOUT END PLATES	4402000A	REG 300 02 WITHOUT END PLATES
3202002A	REG 100 04 WITHOUT END PLATES	3402002A	REG 200 04 WITHOUT END PLATES	4402001A	REG 300 04 WITHOUT END PLATES
3202003A	REG 100 08 WITHOUT END PLATES	3402003A	REG 200 08 WITHOUT END PLATES	4402002A	REG 300 08 WITHOUT END PLATES
3202004A	REG 100 012 WITHOUT END PLATES	3402004A	REG 200 012 WITHOUT END PLATES	4402003A	REG 300 012 WITHOUT END PLATES
3202001	REG 100 1/4 02	3402001	REG 200 1/4 02	4402000	REG 300 1/2 02
3202002	REG 100 1/4 04	3402002	REG 200 1/4 04	4402001	REG 300 1/2 04
3202003	REG 100 1/4 08	3402003	REG 200 1/4 08	4402002	REG 300 1/2 08
3202004	REG 100 1/4 012	3402004	REG 200 1/4 012	4402003	REG 300 1/2 012
3302001	REG 100 3/8 02	3502001	REG 200 3/8 02	4502000	REG 300 3/4 02
3302002	REG 100 3/8 04	3502002	REG 200 3/8 04	4502001	REG 300 3/4 04
3302003	REG 100 3/8 08	3502003	REG 200 3/8 08	4502002	REG 300 3/4 08
3302004	REG 100 3/8 012	3502004	REG 200 3/8 012	4502003	REG 300 3/4 012
		3602001	REG 200 1/2 02	4602000	REG 300 1 02
		3602002	REG 200 1/2 04	4602001	REG 300 1 04
		3602003	REG 200 1/2 08	4602002	REG 300 1 08
		3602004	REG 200 1/2 012	4602003	REG 300 1 012
				SKILLAIR 400 REGULATOR	
				6102001A	REG 400 WITHOUT END PLATES
				6102001	REG 400 1
				6202001	REG 400 1 1/4
				6302001	REG 400 1 1/2
				6402001	REG 400 2