

The superior technology of Skillair® FRL units is the expression of Metal Work innovation. The FRL system is the brainchild of a joint study by Metal Work engineers and researchers from the Department of Mechanics in Turin. The integration of metal alloys and super-resistant techno-polymers is the result of co-operation between CESAP (European Centre for the Development of Plastic Applications) and leading international companies such as Du Pont, EMS Chemie and Hoechst. The installation of advanced processing and quality control systems guarantees the reliability of Skillair® FRLs.

Technical features

The Skillair units incorporate very interesting technological features:

- **Compactness** – with the same flow capacity our unit is one of the smallest on the market.
- **Modularity** – various elements such as filters, reducers, lubricators, 3-way valves, progressive actuators and air take-offs can be combined at will.

With the modular system the FRL units can be removed without disturbing the pipes.

- **Easy maintenance** – Any of the elements or the entire unit can be removed without disturbing the remaining part or pipes.

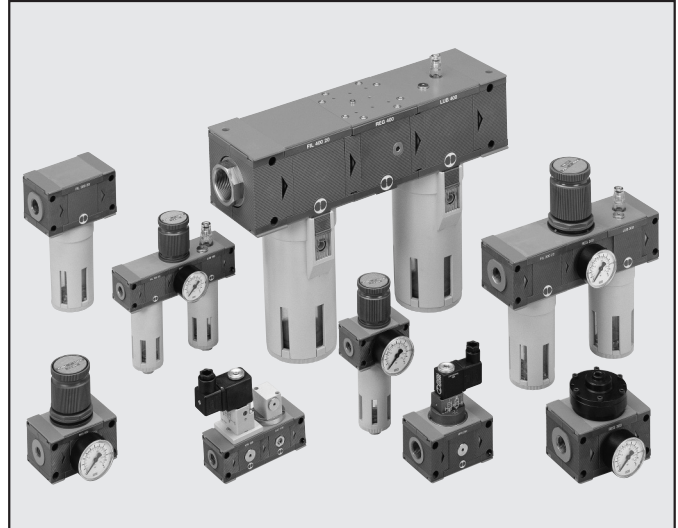

TECHNICAL DATA	SK 100	SK 100	SK 200	SK 200	SK 200	SK 300	SK 300	SK 300	SK 400	SK 400	SK 400	SK 400
Threaded port	1/4"	3/8"	1/4"	3/8"	1/2"	1/2"	3/4"	1"	1"	1" 1/4"	1" 1/2"	2"
Degree of filtration						5µm 20µm 50µm						
Degree of purification						99.97% at 0.01 µm						
Setting range						0-2 0-4 0-8 0-12						
Max. input pressure	1.5		1.3		1.3		1.3		1.3			
	bar		bar		bar		bar		bar			
	psi		psi		psi		psi		psi			
Flow rate at 6.3 bar (0.63 MPa-91 psi)						From 1100 to						
ΔP 0.5 bar (0.05 MPa – 7 psi)						20000 NI/min.						
Fluid						Lubricated or unlubricated compressed air						
Temperature range at 1 MPa; 10 bar; 145 psi						-10°C to +50°C						
						14°F to 122°F						
Elements comprising the range	Filter, Depurator, Regulator, Pilot operated regulator, In-series Regulator, Filter-regulator, Lubricator with various lubricant filling systems, Circuit Shut-off Valve, Progressive Actuator.											
Compatibility with oils	please refer to page 6.1/08											

SKILLAIR MODULARITY

The FRL units can be removed from the system without disturbing the pipes. This can be done with a single element or with the entire system. Assemble the unit so that the air flows in the direction marked by the arrows.

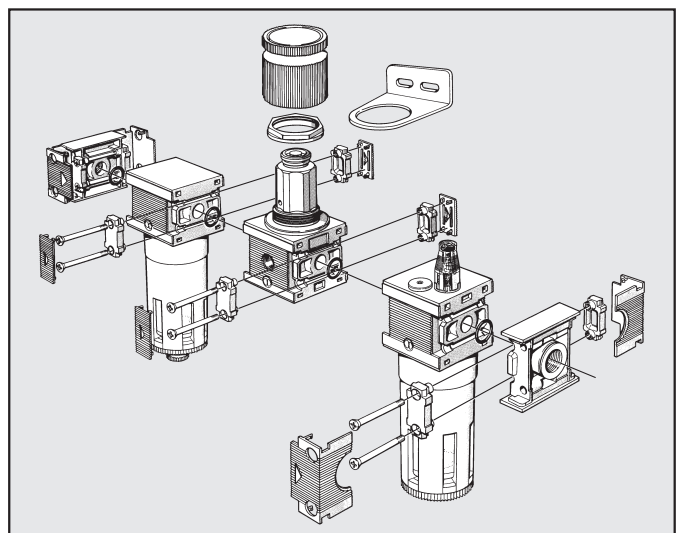

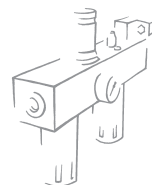

DISASSEMBLING THE UNIT – WALL FIXING

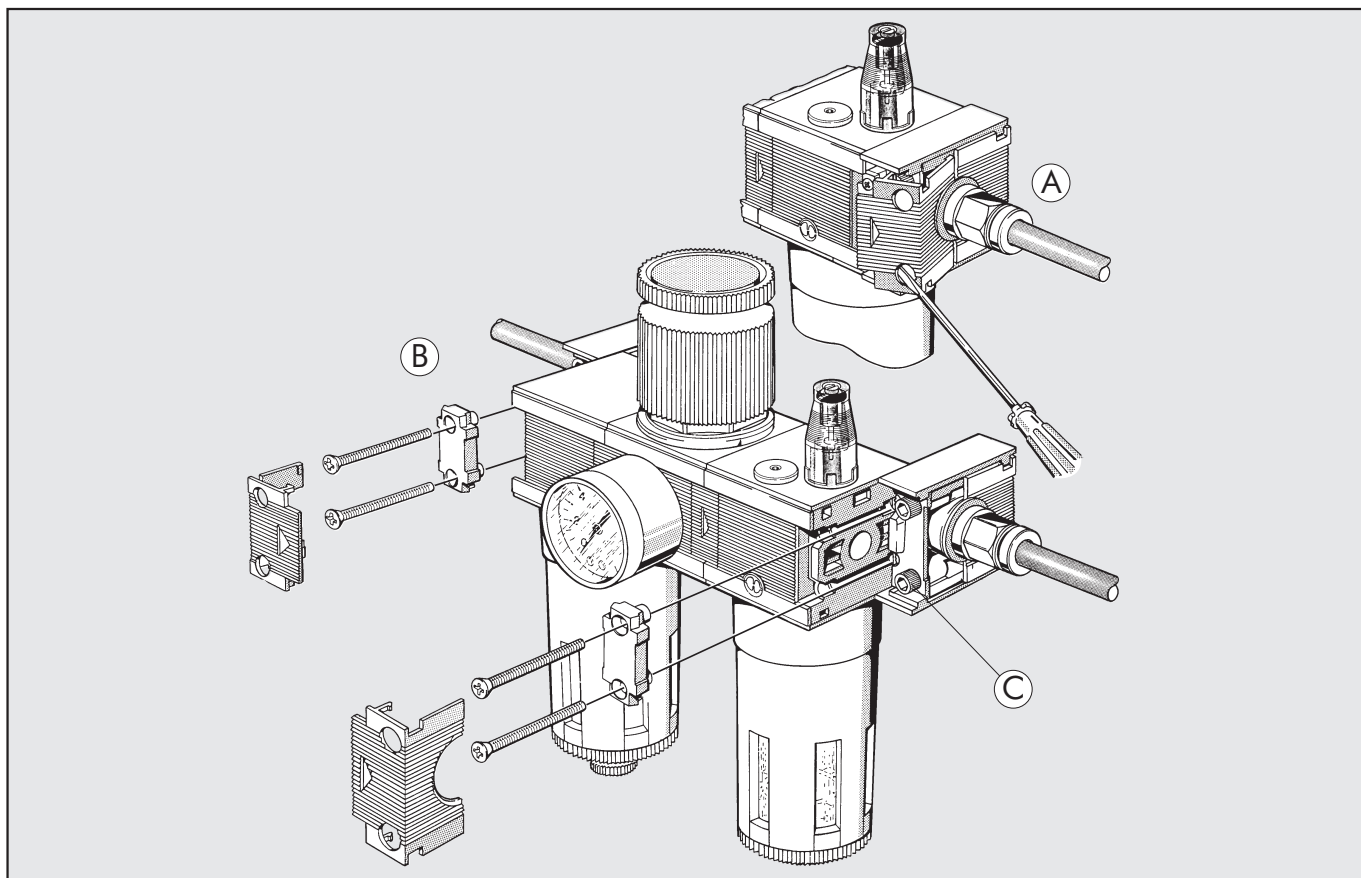

How to disassemble Skillair end plates:

- Remove the plate (A).
- Unscrew the screws and remove the cams (B) to disassemble the unit.
- Screws to fix the end plates to the wall (C):

Series 100: M4x50
Series 200: M5x60
Series 300: M5x70
Series 400: M6x110

SKILLAIR 400 – ROTARY SLIDING JOINT

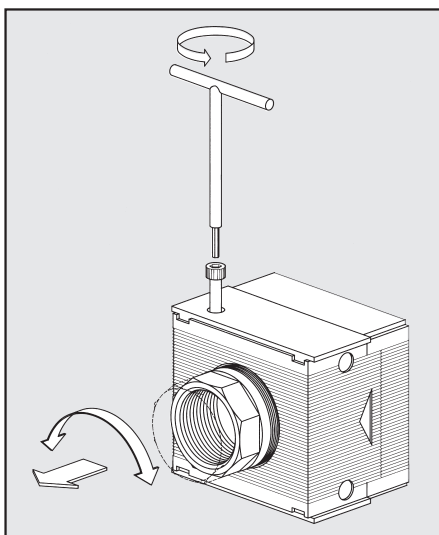

The series 400 comes with a patented system with a rotary sliding end joint to allow the unit to be adapted to the pipe cutting distance.

For correct assembly and disassembly, loosen the screw in the end plate before screwing in or unscrewing the bush.

GENERAL RULES FOR USE AND MAINTENANCE

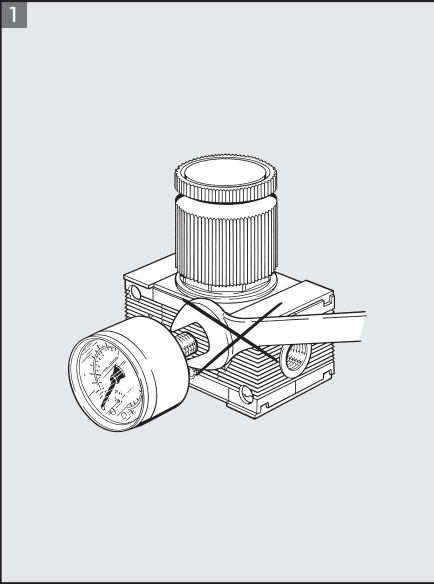

MOUNTING THE PRESSURE GAUGE

- 1 Do not use a spanner.
- 2 The gauge must be mounted by hand. Use liquid sealants only. Do not use Teflon.

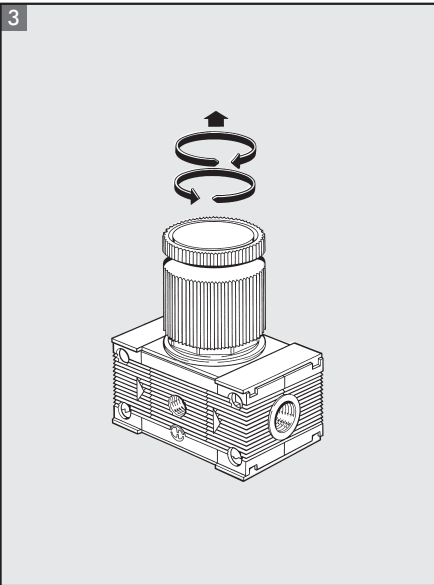
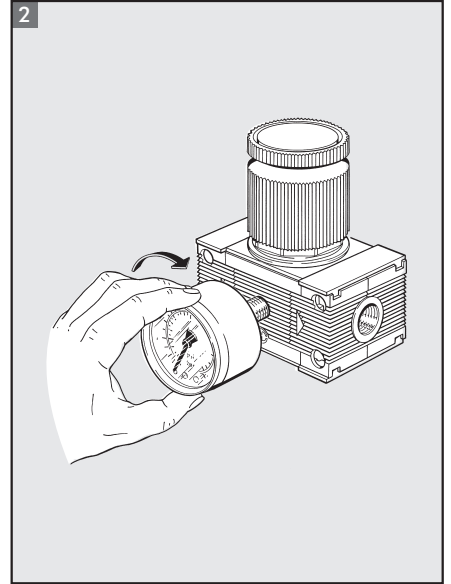

SETTING THE PRESSURE

- 3 NB – The pressure in standard regulators must always be set upwards. Before setting the pressure, check that the knob is raised.
- 4 When the required pressure has been reached, press the knob downwards.

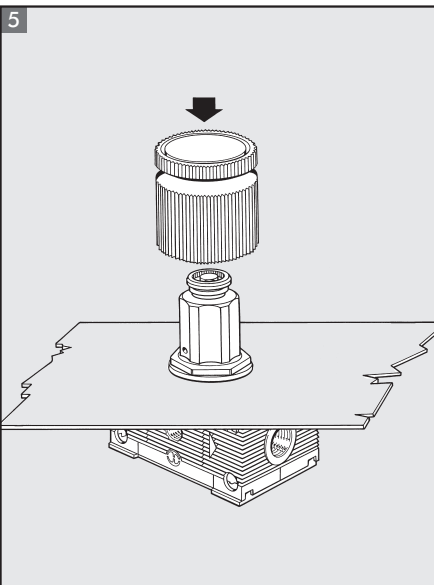
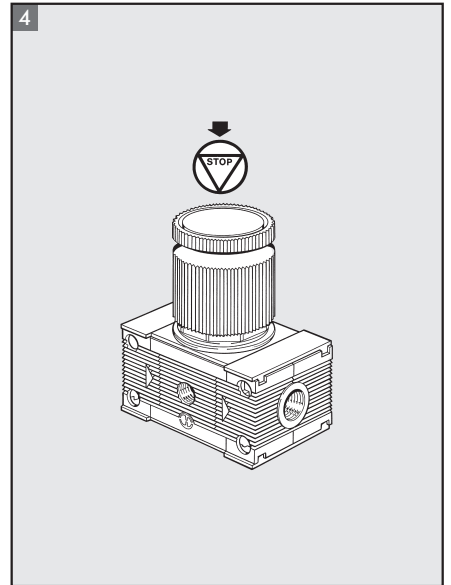

MOUNTING THE REGULATOR AND FILTER-REGULATOR

- 5 Panel mounting: remove the knob and lock the regulator with the ring nut.
- 6 Wall mounting: use a suitable bracket (see Skillair accessories).

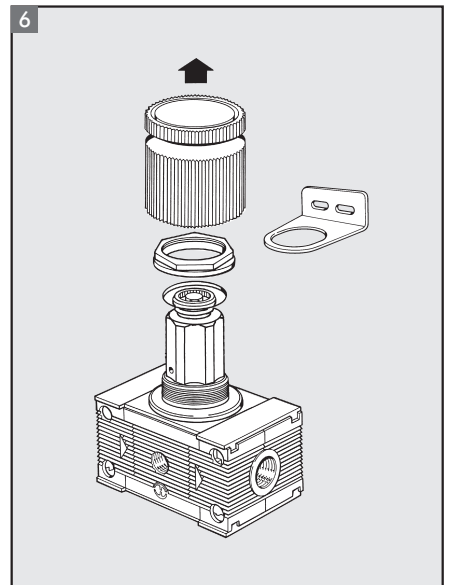

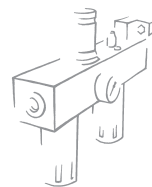

SEMI-AUTO CONDENSATE DRAIN FOR FILTER, FILTER-REGULATOR AND DEPURATOR

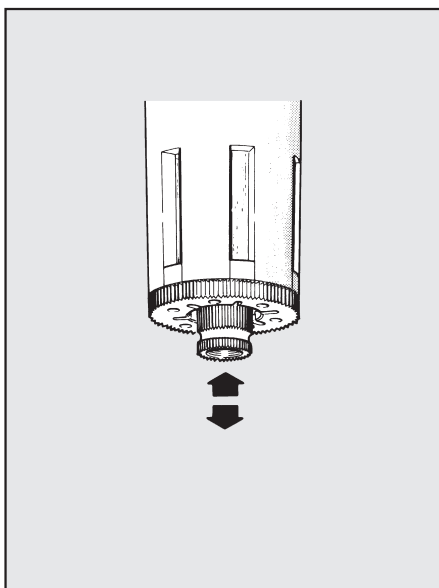

The semi-auto condensate drain is the normally open type. When there is pressure in the bowl, the drain closes. When there is no pressure in the bowl, it opens and the condensate drains out.

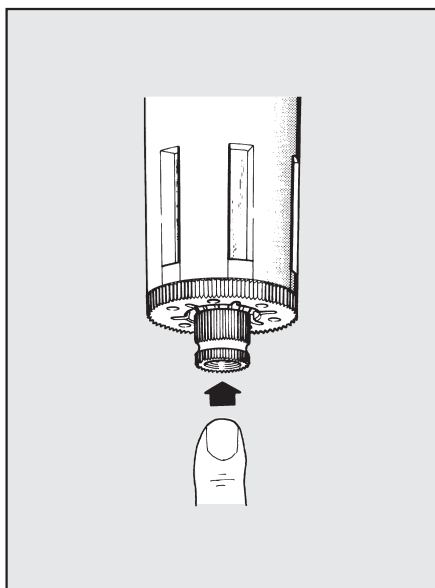

If necessary, it is possible to drain the condensate whilst the bowl is pressurised. The simple manual operation of "pushing up the valve" will allow the condensate to drain.

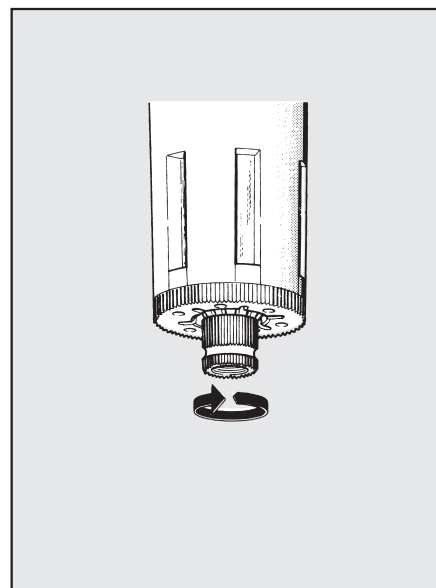

When rotating the button clockwise, the valve becomes in locked position, and can only work when the button is returned to the central position.

3

CLEANING AND/OR REPLACING THE FILTER ELEMENTS

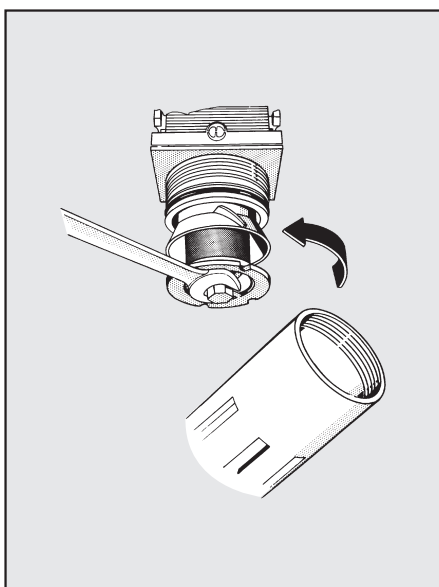

Before unscrewing the bowl to replace the filter elements, check that the line is no longer pressurized. Replace as shown in the diagram.