

# RODLESS CYLINDER WITH GUIDE "V" Ø 25, 32, 40, 63

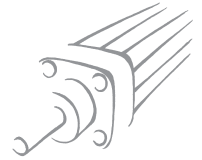

1

Two opposed V-shaped guide units are obtained directly in the anodized aluminium cylinder liner, on which a cover with two acetabular resin wear-resistant pads slides.

The cover has a tip-up-type carriage-piston rod coupling. In this way the carriage only transfers loads axially and does not support loads and moments in other directions. The play of the pads can be adjusted by means of side threaded grub screws. Therefore, it is possible to recover the wear of pads, which can be replaced without the need for dismantling the cylinder.

This family of rodless cylinders has the same features as the basic versions: such as an integrated adjustable pneumatic cushioning, sensor slots and accessory holding slots. A version is available with adjustable limit switches and hydraulic decelerators. They can be purchased separately and applied at any time to the basic cylinders as well.

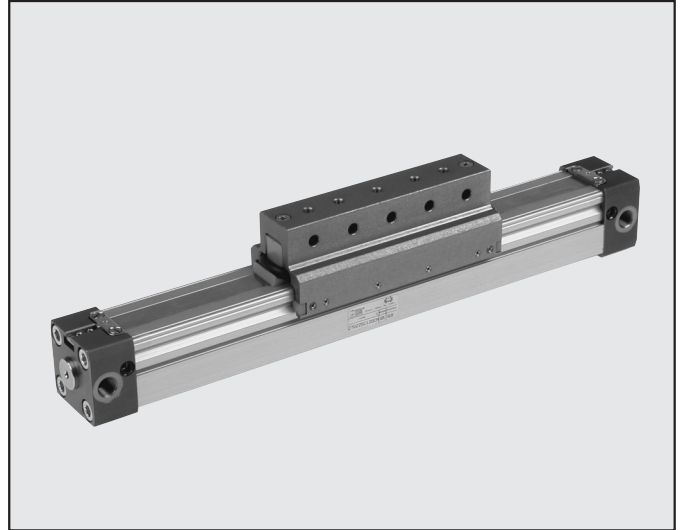

TECHNICAL DATA		NBR	FKM/FPM
Operating pressure	bar	1.5 ÷ 8	
	MPa	0.15 ÷ 0.8	
Temperature range	psi	21.8 ÷ 116	
	°C	-15 ÷ 80	
	°F	-5 ÷ 176	
Fluid		50µm unlubricated filtered air Lubrication, if used, must be continuous.	
Bores	mm	Ø 25, 32, 40 and 63	
Type of construction		Double-acting rodless cylinder with direct transmission system	
Strokes		for Ø 25, 32 and 40 :100 to 5700 mm with 1mm interval	
		for Ø 63 :100 to 5500 mm with 1mm interval	
Recommended speeds		V < 1 m/s (NBR)	V > 1 m/s (FKM/FPM)
Max. speed with decelerators		< 1 m/s (NBR)	2 m/s (FKM/FPM)
Weight		See GENERAL TECHNICAL DATA PAGE 1.1/07	
For no-stick slip versions, use no-lubricated air only			

## COMPONENTS

- ① CYLINDER HEAD: aluminium alloy
- ② BARREL: profiled anodized aluminium alloy
- ③ PISTON GASKET: NBR or FKM/FPM
- ④ CENTRAL ELEMENT: aluminium alloy
- ⑤ SCRAPER: Hostaform®
- ⑥ O-RING: FKM/FPM
- ⑦ PISTON: Hostaform®
- ⑧ CUSHIONING CONE: aluminium alloy
- ⑨ STATIC O-RINGS: NBR or FKM/FPM
- ⑩ SLIDE: aluminium alloy
- ⑪ OUTER STRIP: stainless steel
- ⑫ INNER STRIP: stainless steel
- ⑬ BAND SUPPORT: Hostaform®
- ⑭ "V" GUIDE PLATE: Hostaform®

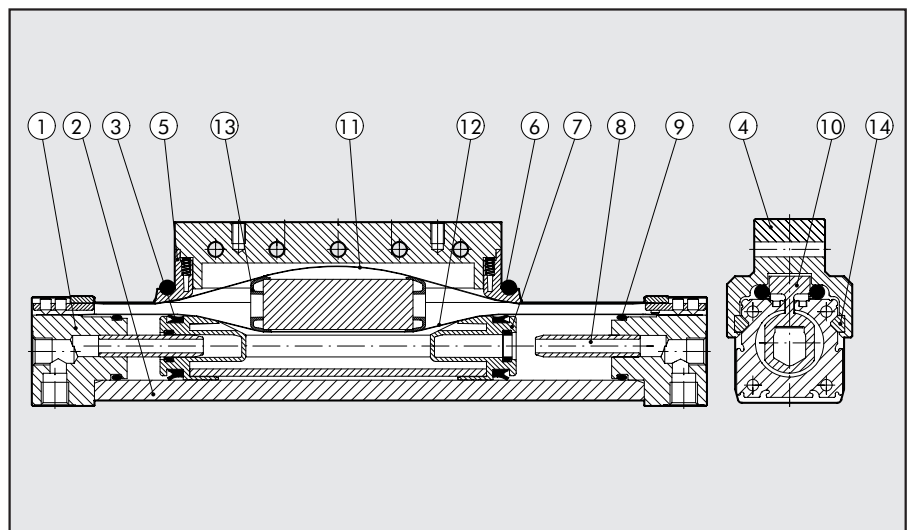

### DIMENSIONING - FORCE AND TORQUE

Bore Ø	Centre Distance Y	Actual Force F at 6 bar [N]	Cushioning stroke [mm]	Max. load L [N]	Ma max [Nm]	Mr max [Nm]	Mv max [Nm]
25	14	200	21	350	22	5	22
32	18	300	26	400	40	10	40
40	22	490	32	700	70	26	70
63	44	1300	40	1800	250	80	250

N.B.: The loads can be applied for speeds below 0.2 m/s. For higher speeds, it is advisable not to exceed 1 m/s.

NB: When the cylinder is subjected simultaneously to torque and force, it is advisable to keep to the following equations.

$$Ma = F \times ha \quad Mr = L \times hv + G \times hr \quad Mv = F \times hv$$

$$\frac{Mv}{Mv_{max}} \leq 1; \quad \frac{L}{L_{max}} \leq 1; \quad \frac{Ma}{Ma_{max}} + \frac{Mr}{Mr_{max}} + 0.22 \times \frac{Mv}{Mv_{max}} + 0.4 \frac{L}{L_{max}} \leq 1$$

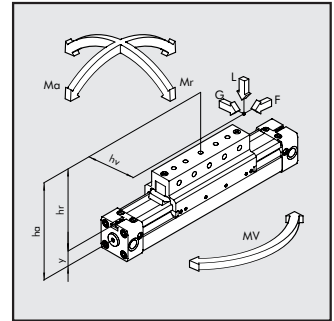

### DIAGRAM OF SPEED AND MAXIMUM CUSHIONABLE LOAD

For the cylinder to reach the end-of-stroke position without intense or repeated impact which would damage it, it is necessary to annul the kinetic energy of the moving mass and the work generated. The maximum cushionable load depends on the traversing speed and the absorption of the air buffer supplied standard with the various cylinders. The diagram shows the speeds and cushionable mass for the various diameters at a pressure of 6 bar.

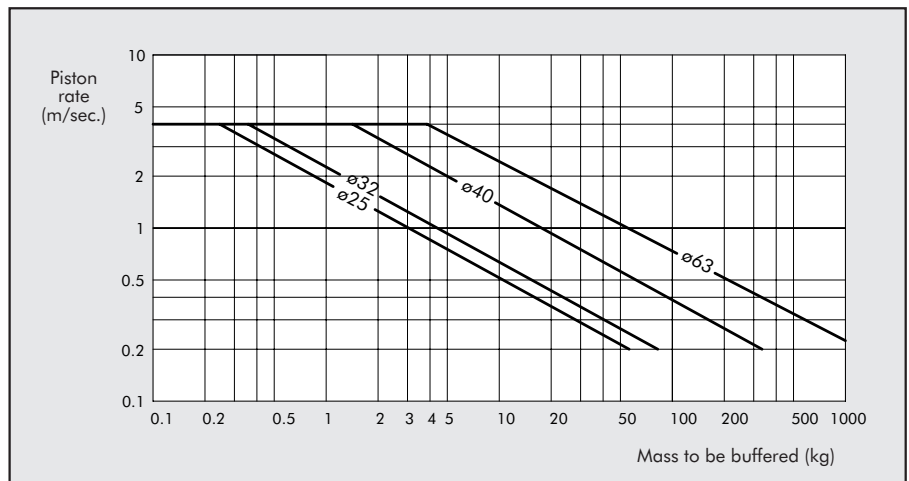

### MAXIMUM LOAD ACCORDING TO THE DISTANCE BETWEEN SUPPORTS

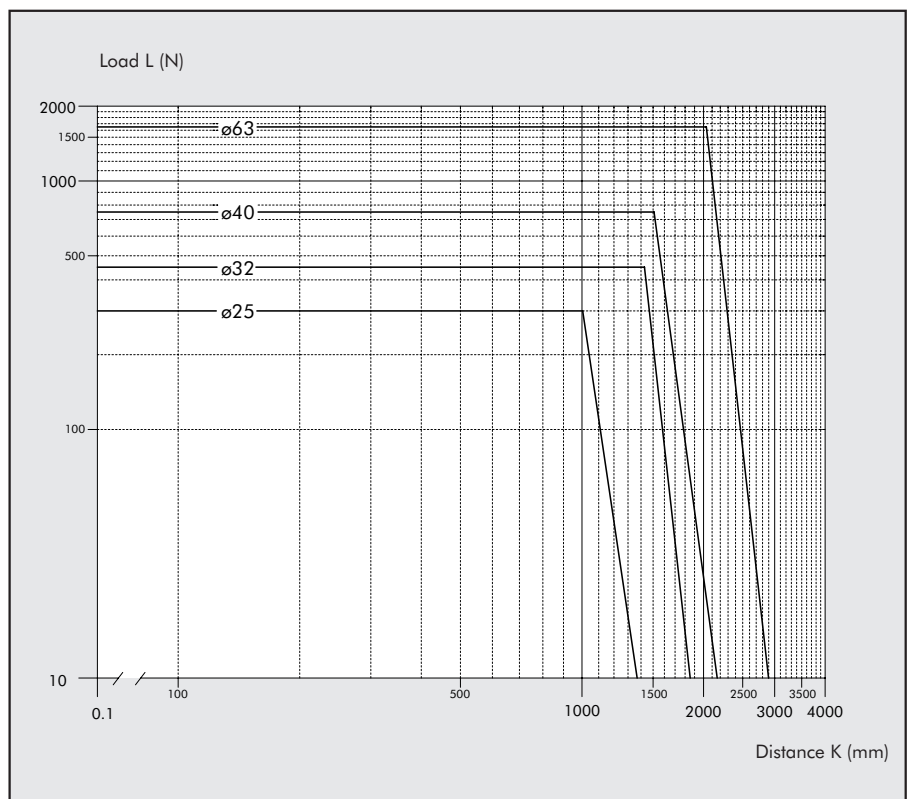
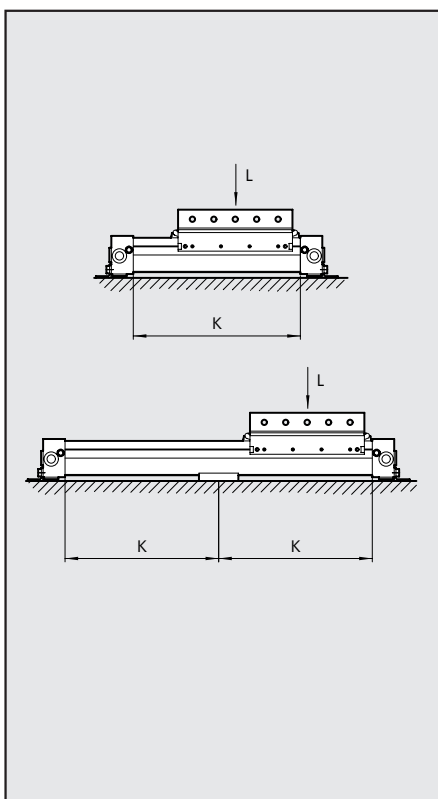



## BARREL CROSS SECTION

1

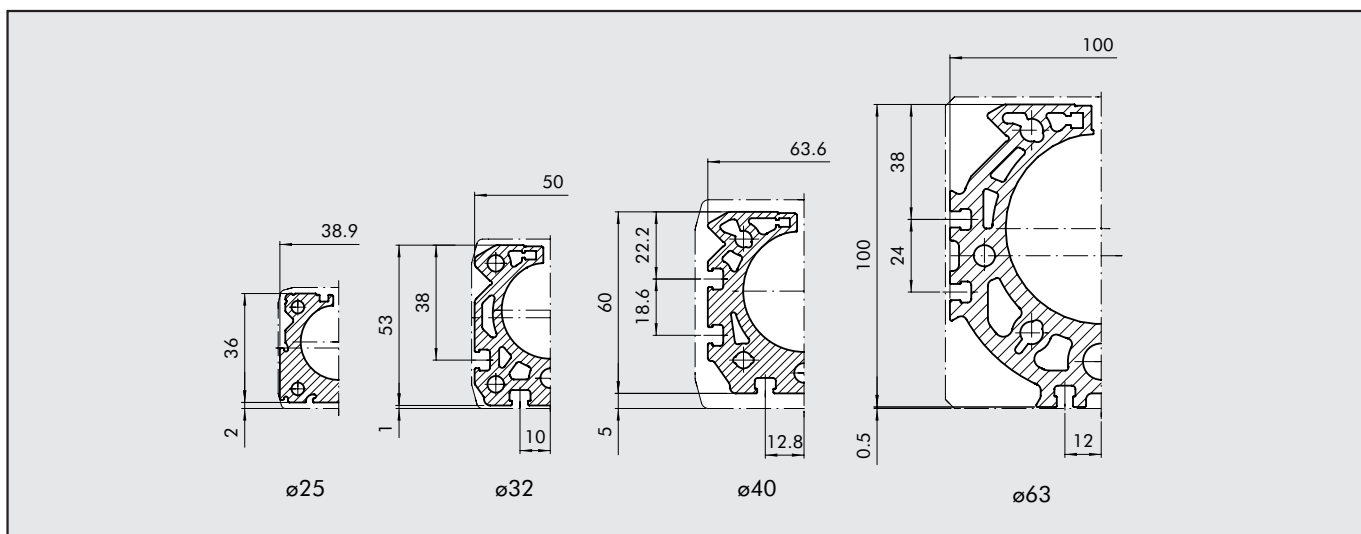

## DIMENSIONS OF RODLESS CYLINDER WITH GUIDE "V" Ø 25÷40

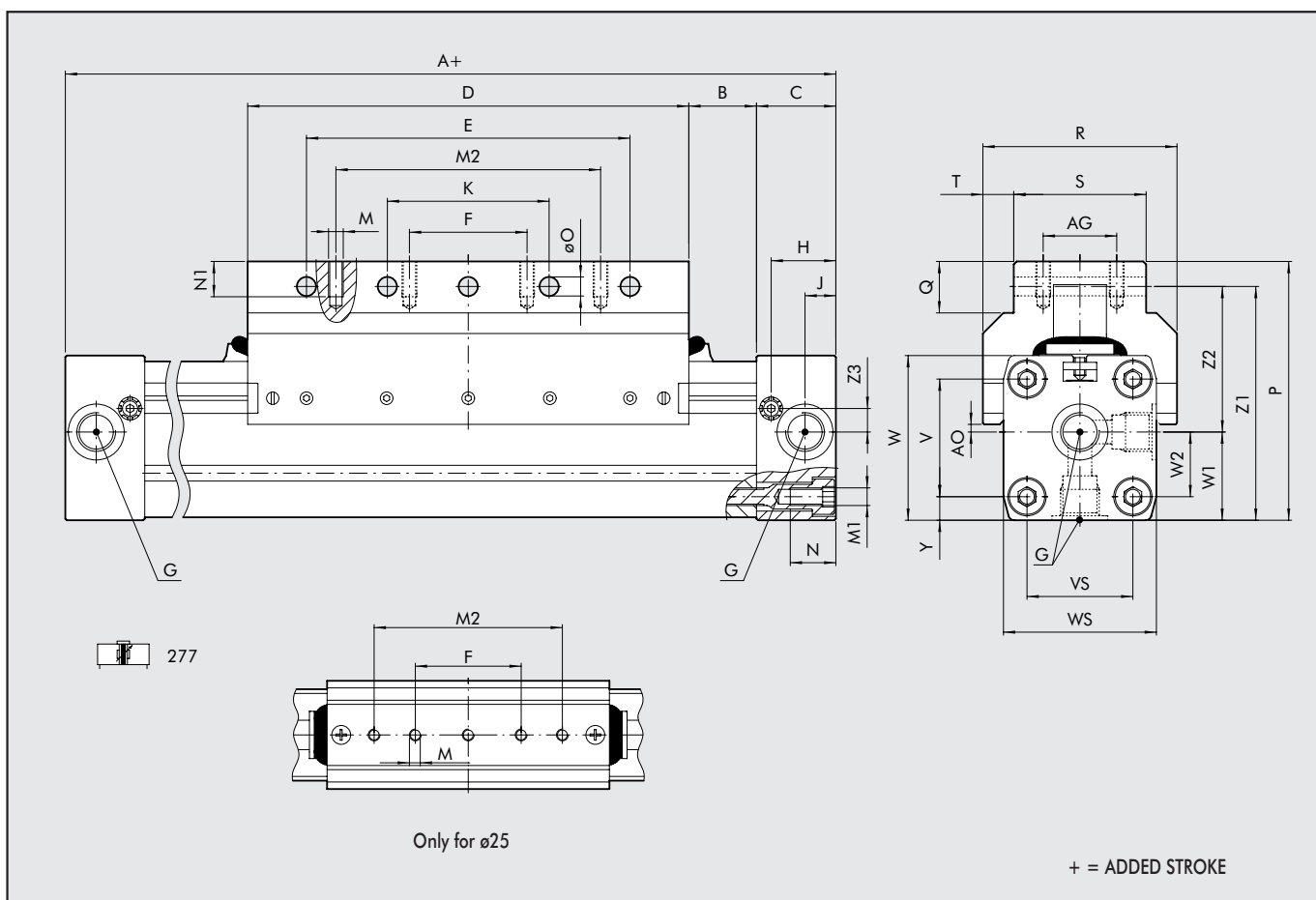

Ø	A	AG	AO	B	C	D	E	F	G	H	J	K	M	M1	M2	N	N1	øO	P	R	S	T	V	VS	W	WS	W1	W2	Y	Z1	Z2	Z3
25	200	-	2	17	23	120	90	45	1/8	18.5	8.5	45	M5	M5	80	12	8	5.5	67.5	46	26	10	27	27	40	40	20	13.5	6.5	57.5	37.5	6.5
32	250	25	2.6	23	27	150	110	40	1/4	22	10.5	55	M5	M6	90	15	12	6.4	88	66	45	10.5	40	36	56	52	30	22	8	79.5	49.5	8
40	300	25	9.4	45	30	150	110	40	1/4	24	15	55	M6	M6	90	17.5	12	6.4	98.5	80	45	17.5	54	54	69	72	36	27	9	89.9	53.9	11.8

### DIMENSIONS OF RODLESS CYLINDER WITH GUIDE "V" Ø63

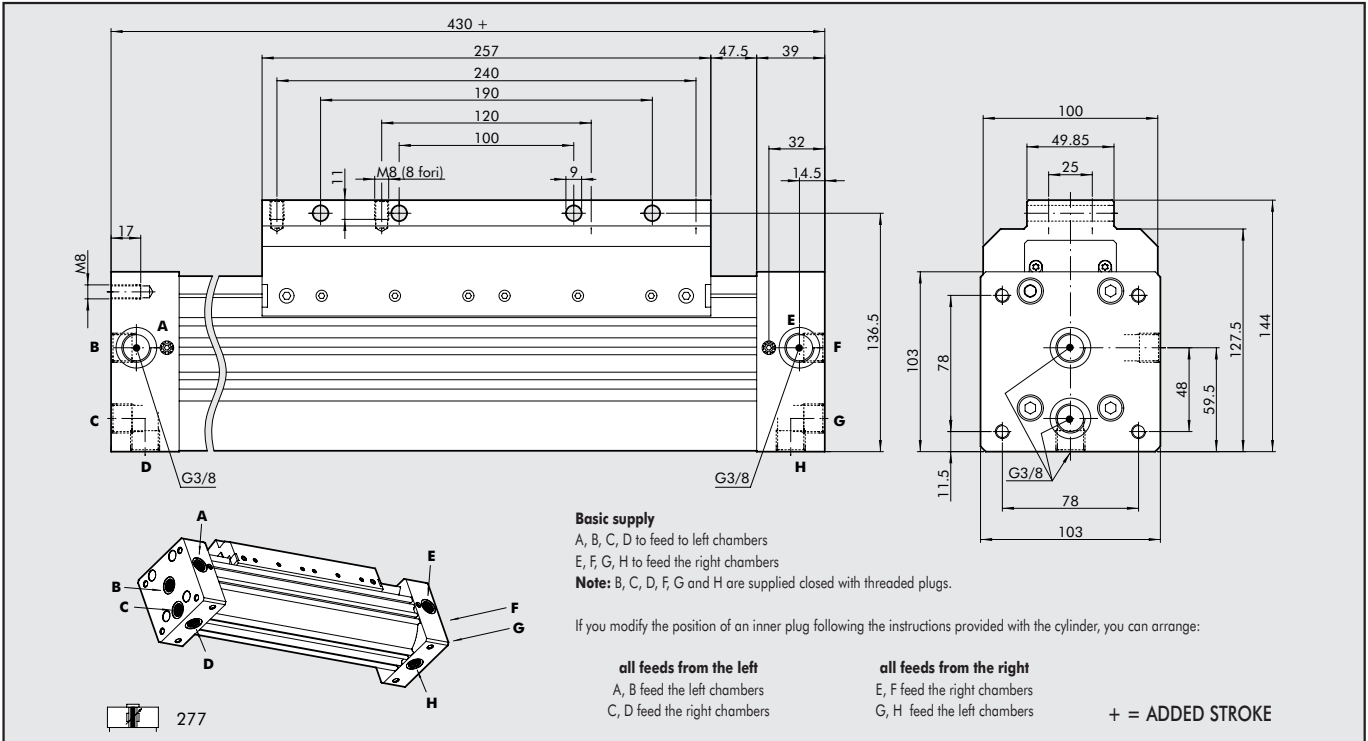

### DIMENSIONS OF RODLESS CYLINDER WITH GUIDE "V" + ADJUSTABLE LIMIT SWITCH AND DECELERATORS

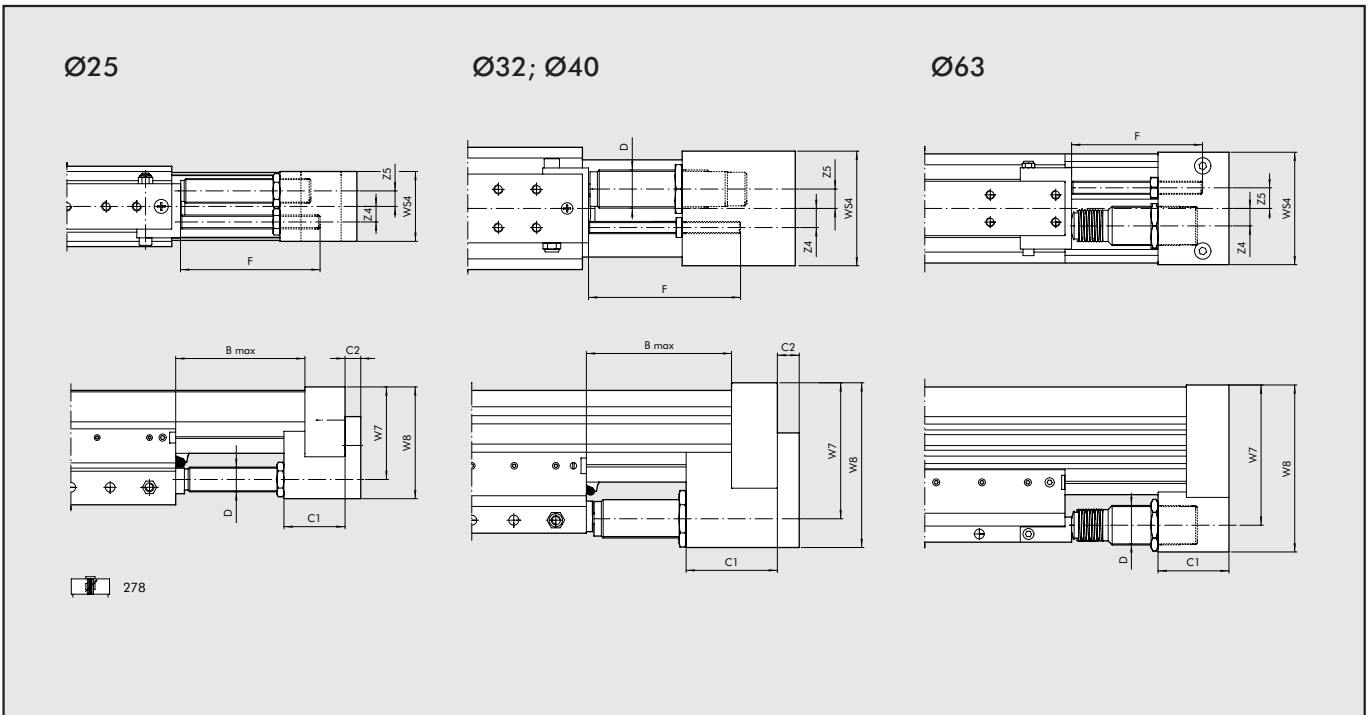

Ø	B Max	C1	C2	D	F	W7	W8	WS4	Z4	Z5	Stroke	Max. cushioned force		Max. impact force [N]	Max. thrust force [N]
												for stroke [J]	for hour [J]		
25	84	35	9	M14x1.5	80	53	67	50	8	9.8	16	26	34000	2800	530
32	110	45	11	M20x1.5	100	74	60	64	10	12.2	22	54	53700	3750	890
40	120	60	14	M25x1.5	100	89	75	80	12.5	12.7	25	90	70000	5500	1550
63	122	65	-	M36x1.5	120	128.5	153	103	16	19	25	160	91000	11120	2220



KEY TO CODES

CYL	2	7	7	0	2	5	0	0	5	0	C	N
	TYPE				BORE		STROKE			CONFIGURATION		
27	Rodless cylinder	7	Double-acting cushioned Magnetic with guide "V"	0 magnetic	25	Ø 25÷40:	C	N	NBR	V**	FKM/FPM	
		8	Double-acting cushioned Magnetic with guide "V" + adjustable limit switches and decelerator	S non-magnetic	32	from 100 to 5700 mm						
				G* No stick slip	40	Ø63						
					63	from 100 to 5500 mm						

\*For speed ≤ 0.2 m/s

\*\*For speed ≥ 1 m/s

ACCESSORIES

FOOT Ø 25	Code	Ø	ØAB	AH	AO	AT	AU	TR	UH	H	Weight [g]
	W0950257001	25	5.5	2	22	2.5	6	27	40	232	32
	Note: Individually packed with 2 screws.										

FOOT Ø 32; 40	Code	Ø	ØAB	AH	AO	AT	AU	AV	TR	UH	H	Weight [g]
	W0950327001	32	6.6	4	25	20	8	20	36	51	284	88
	W0950407001	40	9	2	25	20	11.5	30	54	71	327	112
Note: Individually packed with 2 screws.												

FOOT Ø 63	Code	Ø	ØAB	AT	AO	AU	TR	UH	H	Weight [g]
	W0950637001	63	11	7	64	15	78	103	460	360
	Note: Individually packed with 2 screws.									

INTERMEDIATE SUPPORT Ø 25	Code	Ø	ØAB	AH	AO	AT	TR	UH	Weight [g]
	0950254094	25	5.5	4	20	6	48	60	6
	Note: Individually packed.								

### INTERMEDIATE SUPPORT Ø 32; 40

Code      Ø      ØAB      AH      AO      AT      AV      TR      UH      Weight [g]

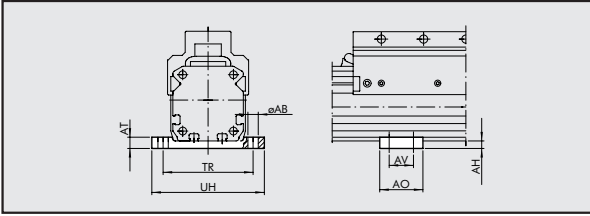

W0950327032	32	6.5	5	55	8	40	61.5	73	72
W0950407032	40	6.5	7	60	8	45	70÷75	85	104

Note: plate supplied complete with 4 screws, 4 fixing plates

### INTERMEDIATE SUPPORT Ø 63

Code      Ø      ØAB      AH      AO      AT      TR      UH      Weight [g]

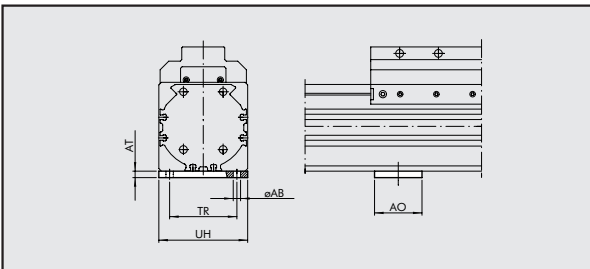

W0950637032	63	8.5	7.5	55	7.5	78	103	330	
-------------	----	-----	-----	----	-----	----	-----	-----	--

Note: plate supplied complete with 4 screws, 4 fixing plates

### RETRACTABLE SENSOR WITH INSERTION FROM ABOVE

Code      Description

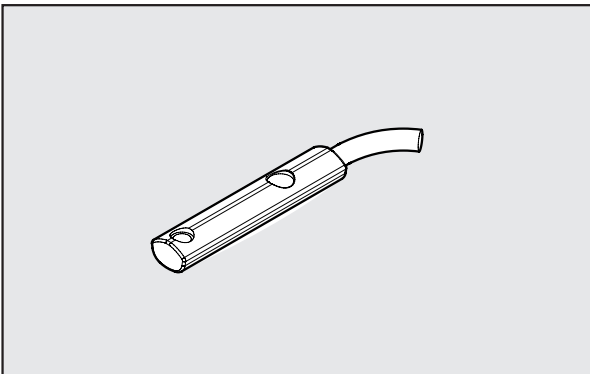

#### FOR Ø25

W0952022500	REED N.O. SENSOR, VERTICAL INSERTION 2.5m
W0952128184	REED N.O. SENSOR, VERTICAL INSERTION 300 mm M8
W0952025500	HALL N.O. SENSOR, VERTICAL INSERTION 2.5m
W0952029395	HALL N.O. SENSOR, VERTICAL INSERTION 300 mm M8

#### FOR Ø32÷63

W0952022180	REED N.O. SENSOR, VERTICAL INSERTION 2.5m
W0952028184	REED N.O. SENSOR, VERTICAL INSERTION 300 mm M8
W0952025390	HALL N.O. SENSOR, VERTICAL INSERTION 2.5m
W0952029394	HALL N.O. SENSOR, VERTICAL INSERTION 300 mm M8
W0952125556	HALL N.O. SENSOR, VERTICAL INSERTION 2m ATEX

This type of sensor can be inserted in the slot of the sensor from above. This means the cylinder heads do not require a through opening.

### WIRING DIAGRAM

### TECHNICAL DATA

### ATEX

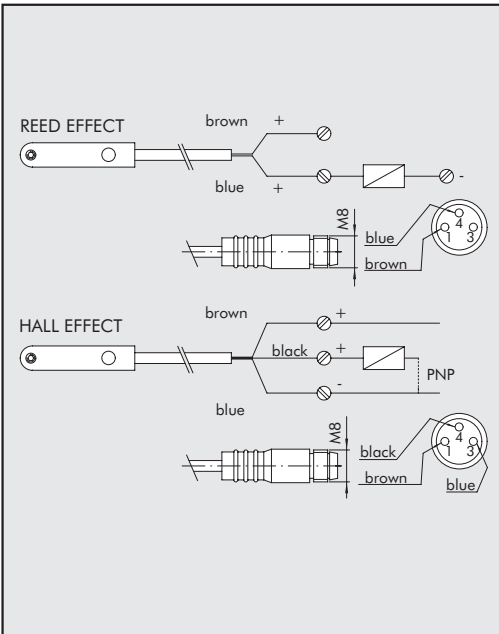

	Reed	Effetto Hall	Effetto Hall
Type of contact	N.O.	N.O.	N.O.
Switch	-	PNP	PNP
Supply voltage (Ub)	V 10 ÷ 30 AC/DC	10 ÷ 30 DC	18 ÷ 30 DC
Power	W 3 (peak valve=6)	3	≤ 1.7
Voltage variation	-	≤ 10% di Ub	≤ 10% di Ub
Voltage drop	V -	≤ 2	≤ 2.2
Input current	mA -	≤ 10	≤ 10
Output current	mA ≤ 100	≤ 100	≤ 70
Switching frequency	Hz ≤ 400	≤ 5000	1000
Short-circuit protection	-	Yes	Yes
Over-voltage suppression	-	Yes	Yes
Polarity inversion protection	-	Yes	Yes
EMC	EN 60 947-5-2	EN 60 947-5-2	EN 60 947-5-2
LED display	Yellow	Yellow	Yellow
Magnetic sensitivity	2,8 mT ±25%	2,8 mT ±25%	2.6
Repeatability	≤ 0,1 mT	≤ 0,1 mT	≤ 0,1 (Ub and ta fixed)
Degree of protection (EN 60529)	IP 67	IP 67	IP 68, IP 69K
Vibration and shock resistance	30 g, 11 ms, 10÷55 Hz, 1mm	30 g, 11 ms, 10÷55 Hz, 1mm	30 g, 11 ms, 10÷55 Hz, 1mm
Temperature range	°C -25 ÷ +75	-25 ÷ +75	-20 ÷ +45
Sensor capsule material	PA66 + PA6I/6T	PA66 + PA6I/6T	PA
2.5m/2m connecting cable	PVC; 2 x 0,12 mm <sup>2</sup>	PVC; 3 x 0,14 mm <sup>2</sup>	PVC; 3 x 0,12 mm <sup>2</sup>
Connecting cable with M8x1	Polyurethane; 2 x 0,14 mm <sup>2</sup>	Polyurethane; 3 x 0,14 mm <sup>2</sup>	-
Wire NO.	2	3	3

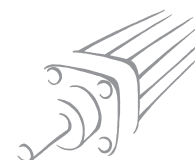

**SENSOR SUPPORT Ø 25** Code Description

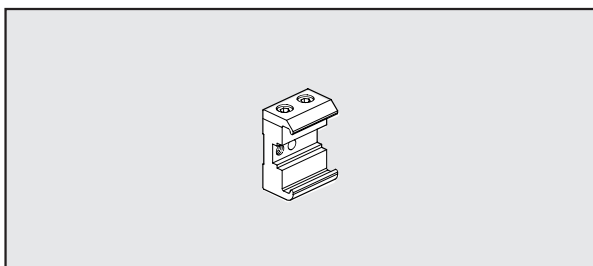

0950164001	SENSOR SUPPORT STD
<b>Note:</b> Supplied with 1 stud pin, 2 screws	

**SLOT STRIP** Code Description

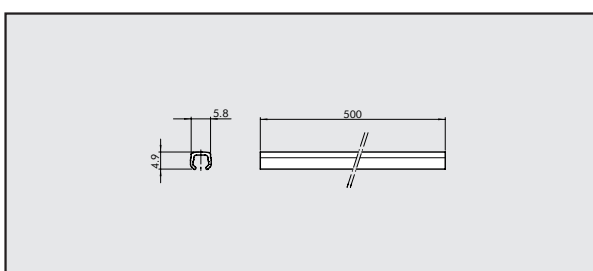

W0950000160	SLOT STRIP 500 mm
<b>Note:</b> the code corresponds to 1 piece	

**KIT FOR CYLINDER ASSEMBLY WITH SENSOR SLOTS** Code Description Weight [g]

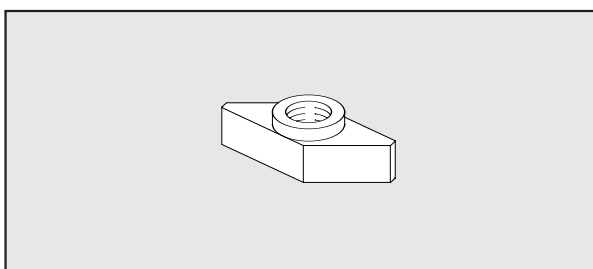

0950003001	ACC. M3 T-SLOTTED FIXING PLATE	1
0950003002	ACC. M4 T-SLOTTED FIXING PLATE	1
<b>Note:</b> Individually packed		

**ADJUSTABLE LIMIT SWITCH AND SHOCK ABSORBERS KIT** Code Description Weight [g]

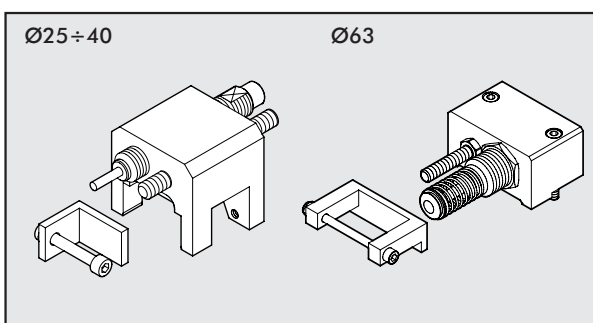

0950254004	ACC. RODLESS CYLINDER LIMIT SWITCH AND SHOCK ABSORBERS Ø 25	260
0950324004	ACC. RODLESS CYLINDER LIMIT SWITCH AND SHOCK ABSORBERS Ø 32	460
0950404004	ACC. RODLESS CYLINDER LIMIT SWITCH AND SHOCK ABSORBERS Ø 40	730
0950634004	ACC. RODLESS CYLINDER LIMIT SWITCH AND SHOCK ABSORBERS Ø 63	1620
<b>Note:</b> Supplied complete with 1 shock absorber support, 1 standard shock absorber, 1 shock absorber nut, 1 limit switch grub screw, 1 grub screw nut (2 for ø63), 1 bracket, 1 bracket screw, 4 locking grub screws (for Ø 25), 4 locking plates and 4 screws (for Ø 32 and Ø 40). For graphs to help shock absorbers, see page 1.1/124		

**SHOCK ABSORBERS** Code Bore Description

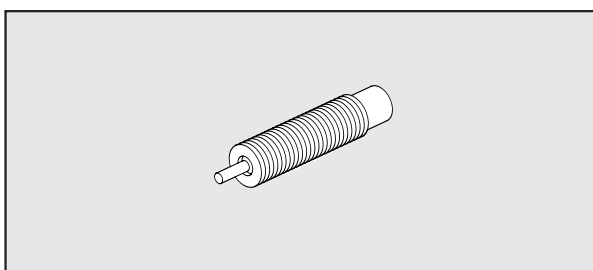

0950004004	ø25	Shock absorbers PR025 MC2 + nut M14x1.5
0950004005	ø32	Shock absorbers PR050 MC2 + nut M20x1.5
0950004006	ø40	Shock absorbers PR0100 MF2 + nut M25x1.5
0950004007	ø63	Shock absorbers PR0125 MF3 + nut M36x1.5

# SPARE PARTS

## "NEW GENERATION" CYLINDER

- ① Bands support Kit
- ② Piston kit
- ③ ④ ⑤ ⑥ ⑦ ⑩ NBR gaskets Kit (FKM/FPM for ⑦)
- ③ ④ ⑤ ⑥ ⑦ ⑩ FKM/FPM gaskets Kit
- ⑧ ⑨ Bands Kit (inner/outer)
- ⑪ "V" guide plate Kit

Spare parts label  
on one cylinder side

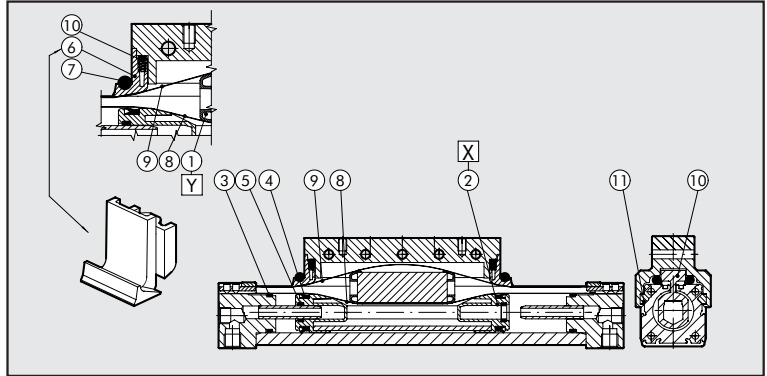
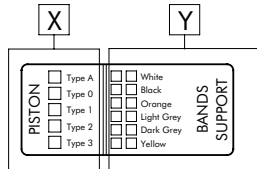

### BANDS SUPPORT KIT POS 1 (Y)

∅	Code White	Code Black	Code Orange	Code Light grey	Code Dark grey	Code Yellow
25	0090255080	0090255081	0090255082	0090255083	0090255084	0090255085
32	0090325080	0090325081	0090325082	0090325083	0090325084	0090325085
40	0090405080	0090405081	0090405082	0090405083	0090405084	0090405085
63	*0090635080	*0090635081	*0090635082	*0090635083	*0090635084	*0090635085

\* For ø63, the kit includes a strip support and a shim in the colour ordered.  
Therefore, two kits must be ordered for each cylinder.

### PISTON KIT POS 2 (X)

∅	Code Type 0 (0 rings)	Code Type 1 (1 rings)	Code Type 2 (2 rings)	Code Type 3 (3 rings)	Code Type A (4 rings)
25	0090255015	0090255016	0090255017	0090255018	0090255019
32	0090325015	0090325016	0090325017	0090325018	0090325019
40	0090405015	0090405016	0090405017	0090405018	-
63	0090635015	0090635016	0090635017	0090635018	-

### BANDS KIT (inner and outer) pos 8-9

∅	Code
25	0090256...
32	0090326...
40	0090406...
63	0090636...      ...= STROKE

### NBR GASKET KIT pos. 3-4-5-6-7-10

∅	Code
25	0090255022
32	0090325022
40	0090405022
63	0090635022

### FKM/FPM GASKET KIT pos. 3-4-5-6-7-10

∅	Code
25	0090255023
32	0090325023
40	0090405023
63	0090635023

### "V" GUIDE PLATE KIT posn. 11

∅	Code
25	0090255060
32	0090325060
40	0090325060
63	0090635060

### NOTES