

DIMENSIONS OF DOUBLE-ACTING

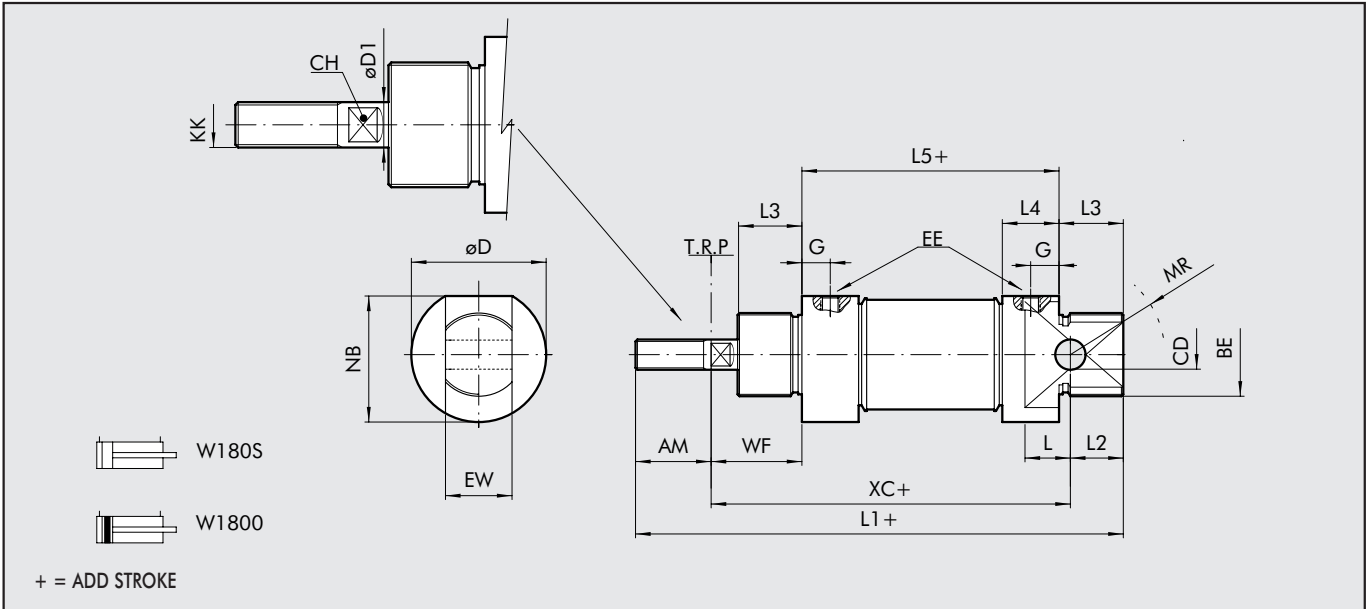

ϕ	AM	BE	ϕCD (H9)	C	H	ϕD	$\phi D1$	EE	EW (d13)	G	KK	L	L1	L2	L3	L5	MR	NB	WF	XC
16	16	M16x1,5	6	5	19	6	M5	12	5	M6	9	109	11	18	55	16	18	22	82	
20	20	M22x1,5	8	7	27	8	G 1/8	16	8	M8	12	131	16	20	67	18	25,5	24	95	
25	22	M22x1,5	8	9	30	10	G 1/8	16	8	M10x1,25	12	140	14	22	68	21	28,5	28	104	

DIMENSIONS DOUBLE-ACTING THROUGH-ROD

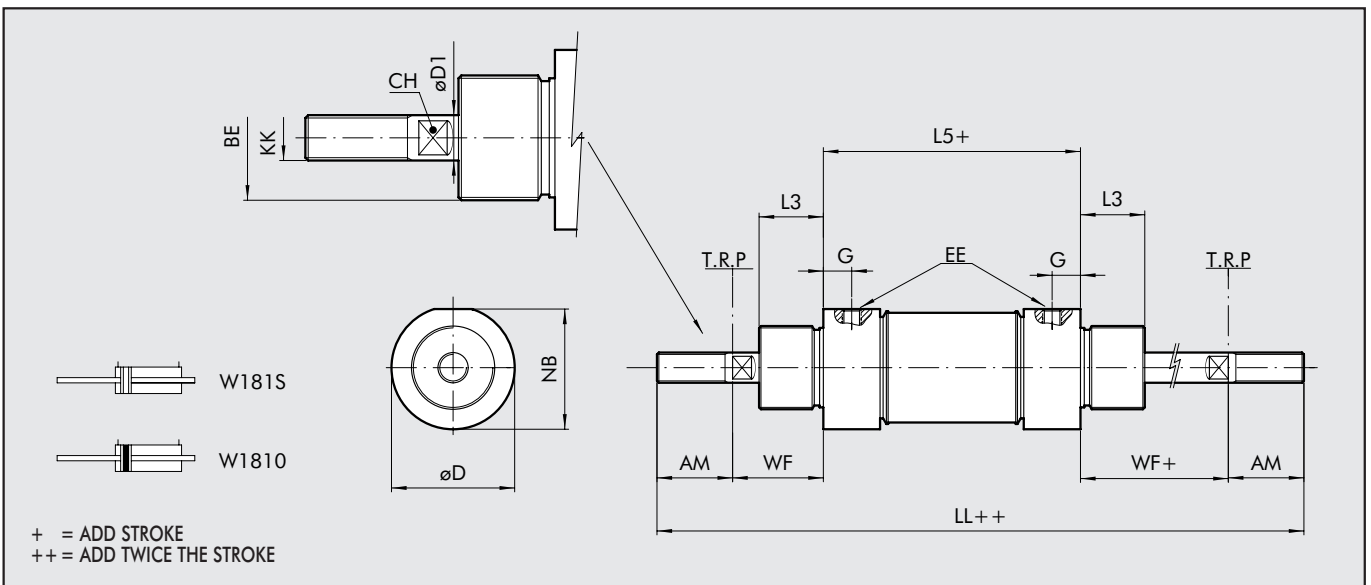

ϕ	AM	BE	CH	ϕD	$\phi D1$	EE	G	KK	LL	L3	L5	NB	WF ($\pm 1,2$)
16	16	M16x1,5	5	19	6	M5	5	M6	129,5	18	55	18	22
20	20	M22x1,5	7	27	8	G 1/8	8	M8	156	20	67	25,5	24
25	22	M22x1,5	9	30	10	G 1/8	8	M10x1,25	169	22	68	28,5	28



KEY TO CODES

W 1 8	0	0	1 6	0 0 2 0
	TYPE	VERSION	DIAMETER	STROKE
Stainless steel cylinder	0 DEM 1 DEM through-rod	0 Standard (magnetic) S Not magnetic V FKM/FPM gasket I Longer piston rod	16 20 25	± Ø 16÷25 stroke 0÷500 mm

DEM: Magnetic double-acting (non-cushioned)

± Maximum recommended strokes. Higher values can create operating problems

ACCESSORIES: FIXINGS

STAINLESS STEEL LEG MODEL A

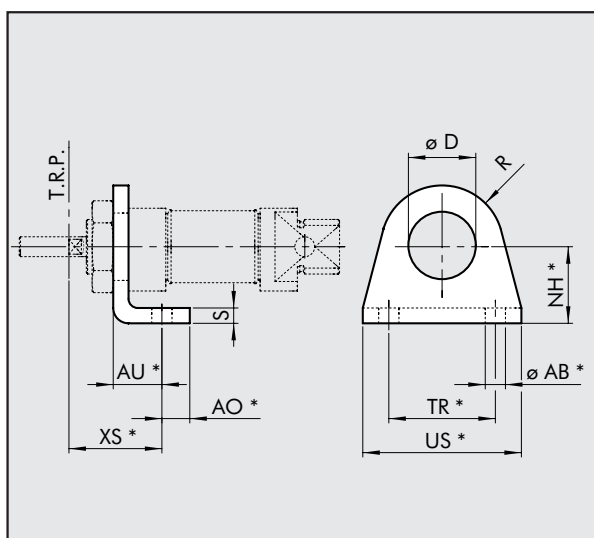

Code	Ø	ØAB	AU	AO	D	NH	XS (±1.4)	R	S	TR	US	Weight [g]
W095X120001	16	5,5	14	6	16,1	20	22	13	4	32	42	42
W095X200001	20	6,6	17	8	22,1	25	36	20	5	40	54	90
W095X200001	25	6,6	17	8	22,1	25	40	20	5	40	54	90

*ISO 6432 values

Note: Individually packed

STAINLESS STEEL FLANGE MODEL C

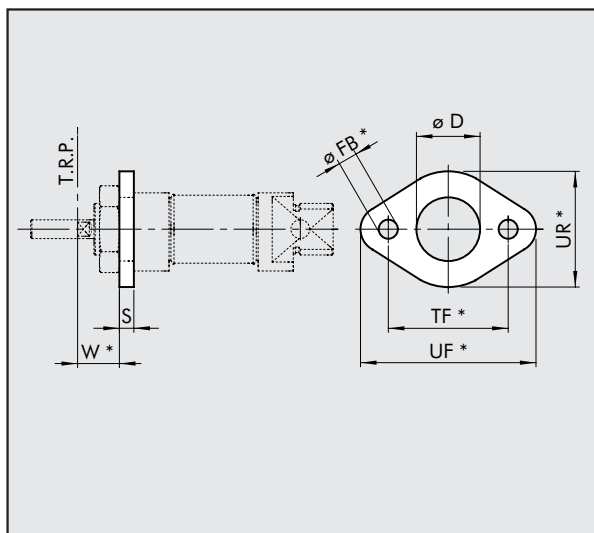

Code	Ø	D	FB	W (±1.4)	S	TF	UF	UR	Weight [g]
W095X120002	16	16	5.5	18	4	40	52	30	26
W095X200002	20	22	6.6	19	5	50	66	40	52
W095X200002	25	22	6.6	23	5	50	66	40	52

*ISO 6432 values

Note: Individually packed

STAINLESS STEEL COUNTER-HINGE MODEL BC

Code	Ø	AB1	AB	AO	LG	MO	N	NH	R	S	TR	Weight [g]
------	---	-----	----	----	----	----	---	----	---	---	----	------------

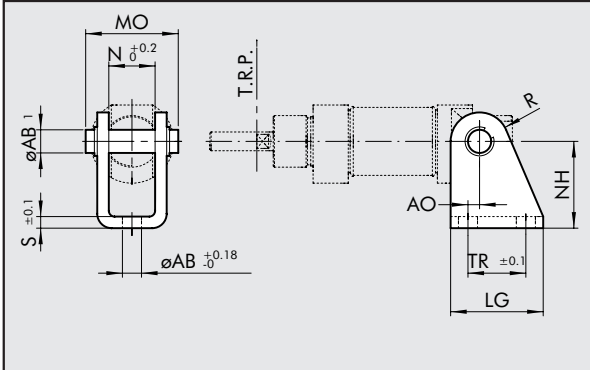

W095X120005	16	6	5.5	2	25	24	12.1	27	7	3	15	40
W095X200005	20	8	6.6	4	32	31	16.1	30	10	4	20	78
W095X200005	25	8	6.6	4	32	31	16.1	30	10	4	20	78

Note: Supplied complete with 1 pin and 2 snap rings

STAINLESS STEEL NUT FOR HEADS

Code	Ø	CH	F	H
------	---	----	---	---

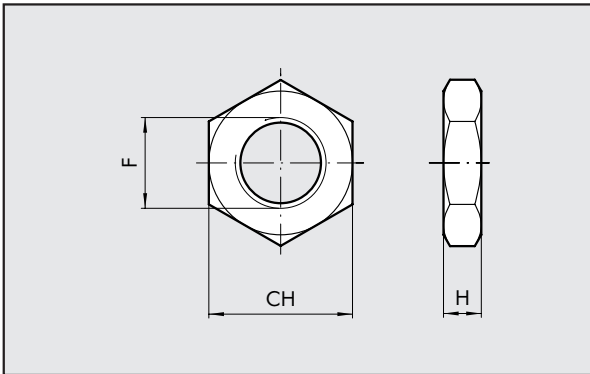

W095X120010	16	22	M16x1.5	5
W095X200010	20	27	M22x1.5	8
W095X200010	25	27	M22x1.5	8

Note: Individually packed

STAINLESS STEEL NUT FOR PISTON RODS

Code	Ø	CH	F	H	Weight [g]
------	---	----	---	---	------------

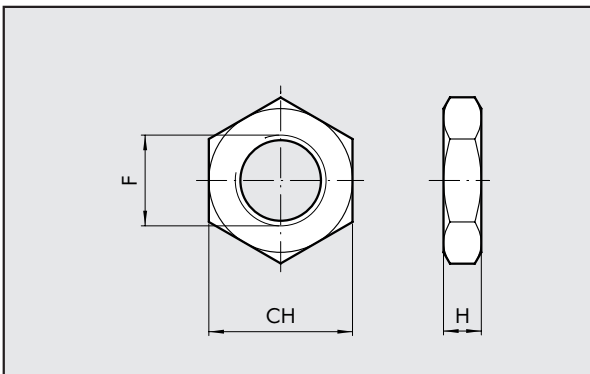

W095X120011	16	10	M6	4	1
W095X200011	20	13	M8	5	3
W095X322011	25	17	M10x1.25	6	7

Note: Individually packed

STAINLESS STEEL FORK-MODEL GK-M

Code	Ø	A	B	C	D	F	L	Ø M
------	---	---	---	---	---	---	---	-----

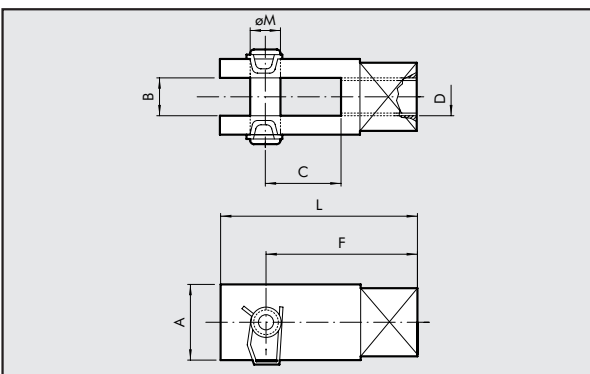

W095X120020	16	12	6	12	M6	24	31	6
W095X200020	20	16	8	16	M8	32	42	8
W095X322020	25	20	10	20	M10x1.25	40	52	10

Note: Individually packed



ACCESSORIES: MAGNETIC SENSORS

SLIM SENSOR

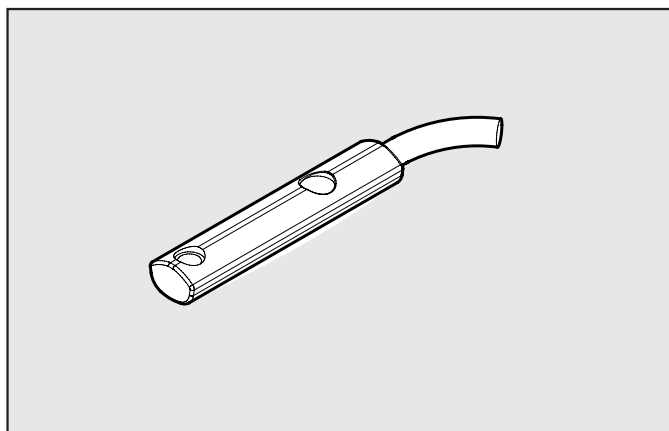

Code	Description
W0952025390	HALL N.O. SENSOR, VERTICAL INSERTION 2.5m
W0952029394	HALL N.O. SENSOR, VERTICAL INSERTION 300 mm M8
W0952022180	REED N.O. SENSOR, VERTICAL INSERTION 2.5m
W0952028184	REED N.O. SENSOR, VERTICAL INSERTION 300 mm M8
W0952125556	HALL N.O. SENSOR, VERTICAL INSERTION 2m ATEX

WIRING DIAGRAM

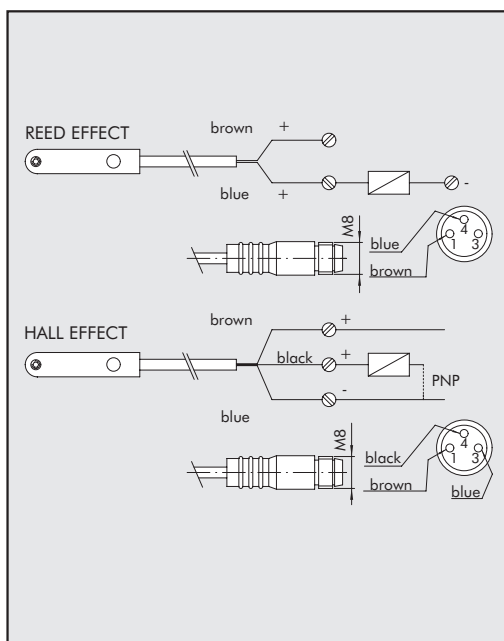

TECHNICAL DATA

	Reed	Effetto Hall	Effetto Hall
Type of contact	N.O.	N.O.	N.O.
Switch	-	PNP	PNP
Supply voltage (U _b)	V 10 ÷ 30 AC/DC	10 ÷ 30 DC	18 ÷ 30 DC
Power	W 3 (peak valve=6)	3	≤ 1.7
Voltage variation	-	≤ 10% di U _b	≤ 10% di U _b
Voltage drop	V -	≤ 2	≤ 2.2
Input current	mA -	≤ 10	≤ 10
Output current	mA ≤ 100	≤ 100	≤ 70
Switching frequency	Hz ≤ 400	≤ 5000	1000
Short-circuit protection	-	Yes	Yes
Over-voltage suppression	-	Yes	Yes
Polarity inversion protection	-	Yes	Yes
EMC	EN 60 947-5-2	EN 60 947-5-2	EN 60 947-5-2
LED display	Yellow	Yellow	Yellow
Magnetic sensitivity	2,8 mT ±25%	2,8 mT ±25%	2.6
Repeatability	≤ 0,1 mT	≤ 0,1 mT	≤ 0,1 (U _b and ta fixed)
Degree of protection (EN 60529)	IP 67	IP 67	IP 68, IP 69K
Vibration and shock resistance	30 g, 11 ms, 10÷55 Hz, 1mm	30 g, 11 ms, 10÷55 Hz, 1mm	30 g, 11 ms, 10÷55 Hz, 1mm
Temperature range	°C -25 ÷ +75	-25 ÷ +75	-20 ÷ +45
Sensor capsule material	PA66 + PA6I/6T	PA66 + PA6I/6T	PA
2.5m/2m connecting cable	PVC; 2 x 0,12 mm ²	PVC; 3 x 0,14 mm ²	PVC; 3 x 0,12 mm ²
Connecting cable with M8x1	Polyurethane; 2 x 0,14 mm ²	Polyurethane; 3 x 0,14 mm ²	-
Wire NO.	2	3	3

SENSOR CIRCLIP

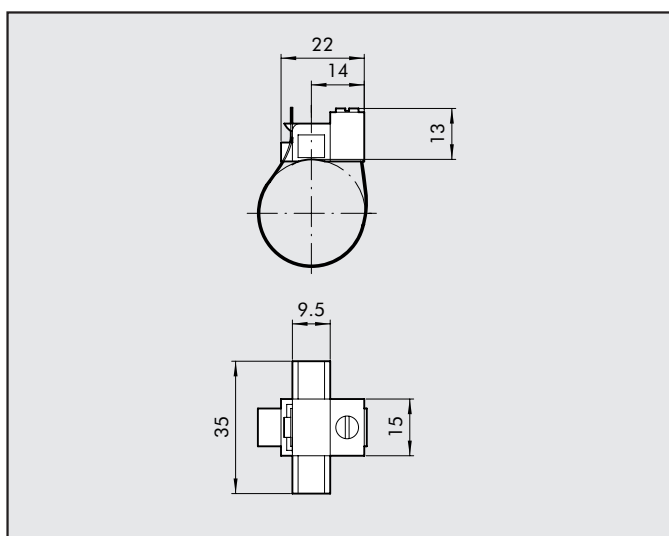

Codice	Alesaggio	Modello
W0950001103	8÷63	SENSOR CIRCLIP

Note: Individually packed

MATERIAL

Circlip: stainless steel
Sensor holder: plastic

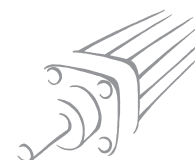

DIMENSIONS OF DOUBLE-ACTING

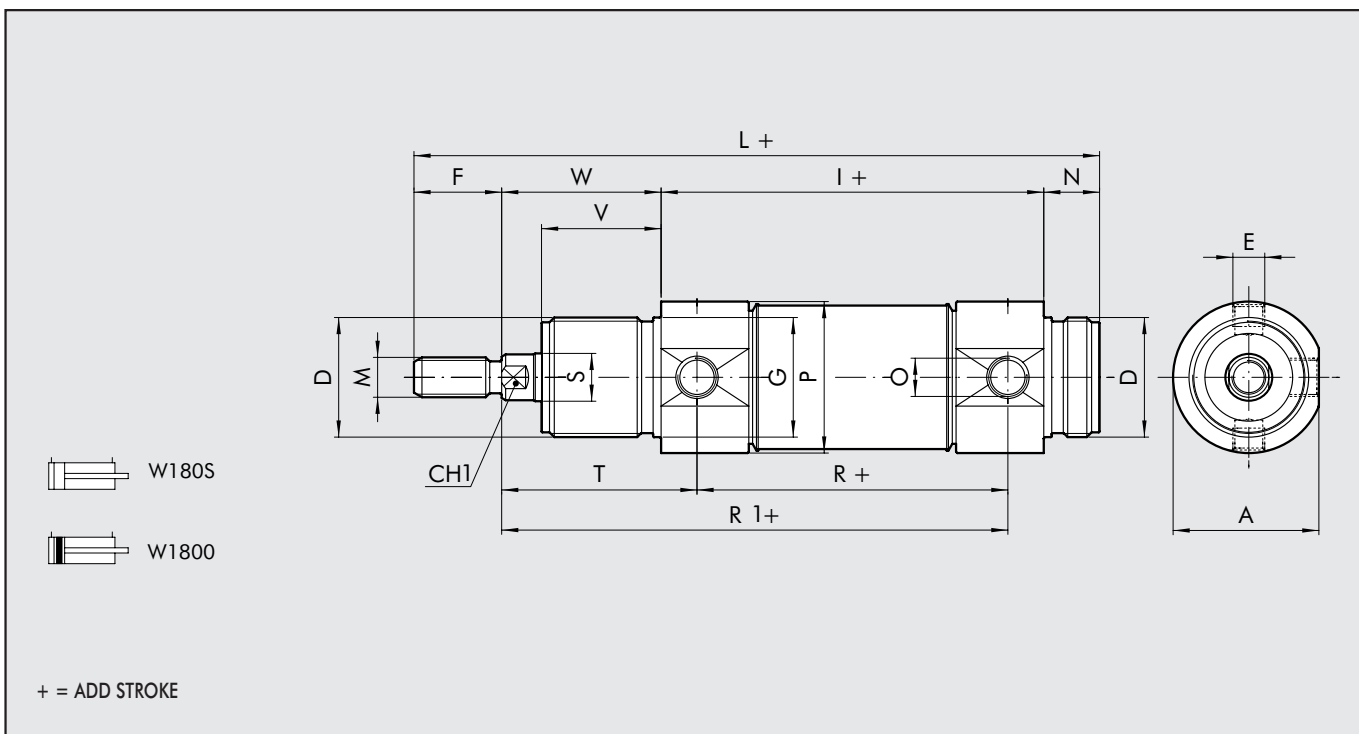

DIMENSIONS DOUBLE-ACTING THROUGH-ROD

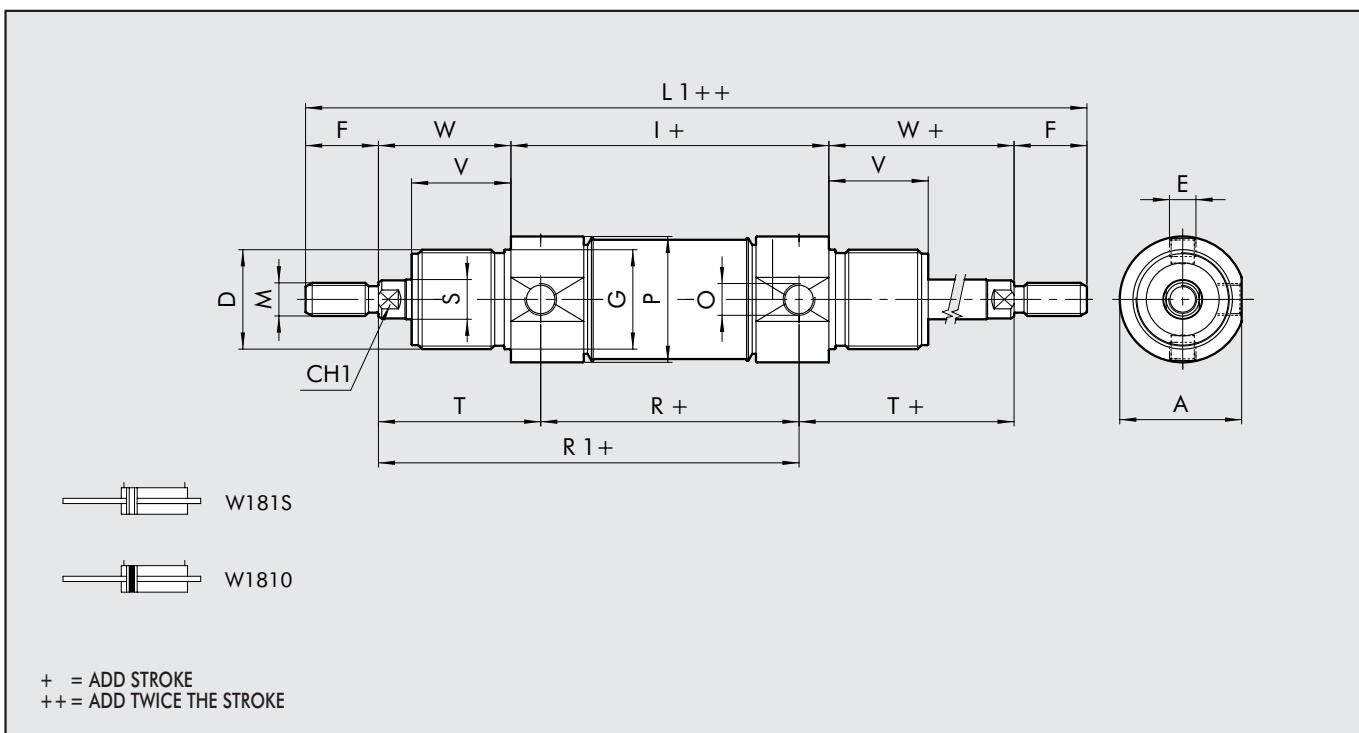

Ø	A	CH1	D	E	F	ØG	I	L	L1	M	N	O	ØP	R	ØS	T	V	W
32	36.5	10	M30x1.5	M8x1	20	30	96	168	212	M10x1.5	14	G1/8	38	78	12	47	30	38
40	44	13	M38x1.5	M10x1	24	38	113	198	251	M12x1.75	16	G1/4	46	89	16	57	35	45
50	55	17	M45x1.5	M12x1.5	32	45	120	220	284	M16x2	18	G1/4	57	96	20	62	38	50
63	67.5	17	M45x1.5	M14x1.5	32	45	124	224	288	M16x2	18	G3/8	70	98	20	63	38	50

KEY TO CODES

W 1 8	0	0	3 2	0 0 5 0
	TYPE	VERSION	DIAMETER	STROKE
Stainless steel cylinder	0 DEM 1 DEM through-rod	0 Standard (magnetic) S Not magnetic V FKM/FPM gasket I Longer piston rod	32 40 50 63	± Ø 32 ÷ 63 stroke 0 ÷ 500 mm

DEM: Magnetic double-acting (non-cushioned)

± Maximum recommended strokes. Higher values can create operating problems

ACCESSORIES: FIXINGS

STAINLESS STEEL LEG MODEL AC

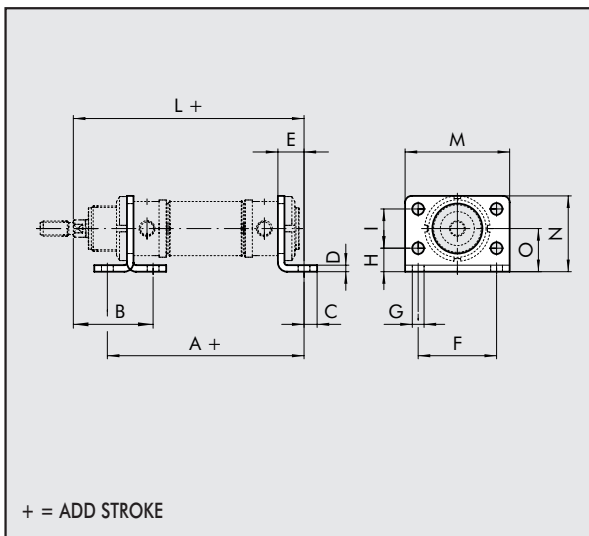

Code	Ø	A	B	C	D	E	F	G	H	I	L	M	N	O
W095X320002	32	124	48	7	4	14	52	7	14	28	148	66	49	28
W095X400002	40	153	60	10	5	20	60	9	18	30	178	80	58	33
W095X500002	50	160	64	10	6	20	70	9	20	40	190	90	70	40
W095X630002	63	164	64	10	6	20	76	9	20	50	194	96	80	45

Note: Individually packed

STAINLESS STEEL COUNTER-HINGE MODEL BC

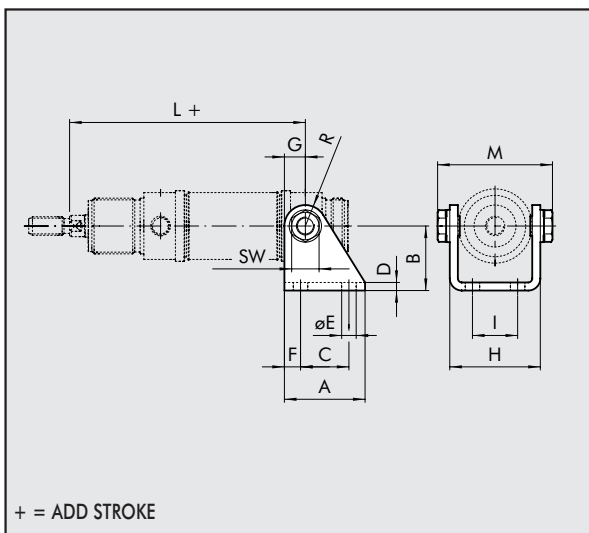

Code	Ø	A	B	C	D	E	F	G	H	I	L	M	R
W095X320005	32	40	35	24	4	7	8	12	46.1	20	125	58.1	12
W095X400005	40	50	40	30	5	9	10	13	56.1	28	146	70.1	13
W095X500005	50	54	45	34	6	9	10	14	69.1	36	158	86.1	14
W095X630005	63	65	50	35	6	9	15	16	82.1	42	161	99.1	16

Nota: Supplied complete with 2 screws



STAINLESS STEEL HEAD RING NUT MODEL G

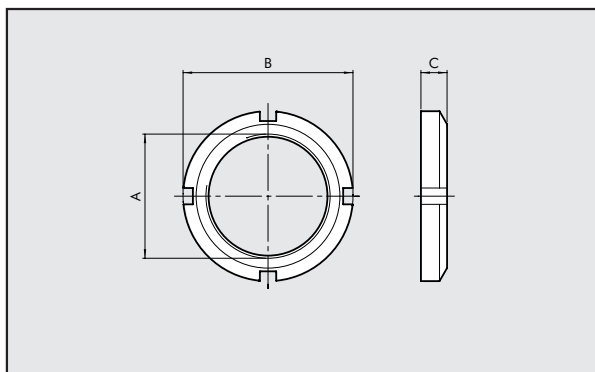

Code	Ø	A	B	C
W095X320010	32	M30x1.5	45	7
W095X400010	40	M38x1.5	52	8
W095X500010	50	M45x1.5	58	9
W095X500010	63	M45x1.5	58	9

Note: Individually packed

STAINLESS STEEL FORK-MODEL GK-M

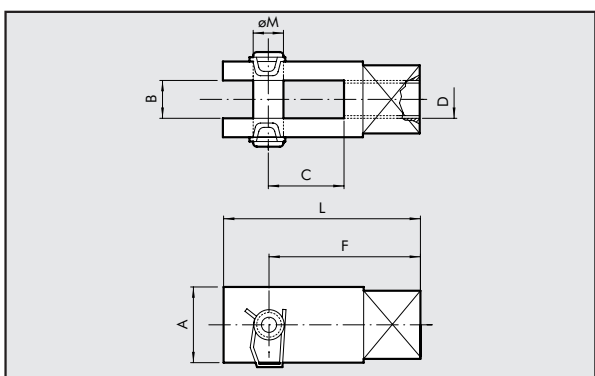

Code	Ø	A	B	C	D	F	L	ØM
W095X320020	32	20	10	20	M10x1.5	40	52	10
W095X400020	40	24	12	24	M12x1.75	48	62	12
W095X500020	50	32	16	32	M16x2	64	83	16
W095X500020	63	32	16	32	M16x2	64	83	16

Note: Individually packed

STAINLESS STEEL NUT FOR PISTON RODS

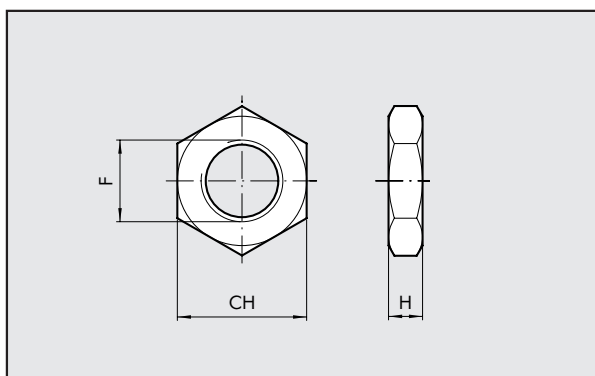

Code	Ø	F	CH	H	Weight [g]
W095X320011	32	M10x1.5	17	6	6
W095X400011	40	M12x1.75	19	7	12
W095X500011	50	M16x2	24	8	20
W095X500011	63	M16x2	24	8	20

Note: Individually packed

STAINLESS STEEL OSCILLATING PIN

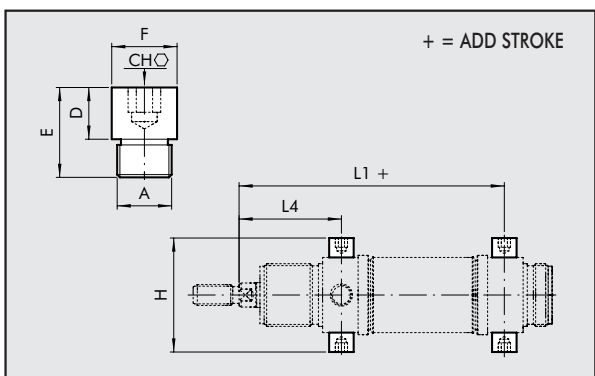

Code	Ø	A	CH	D	E	øF	H	L1	L4
W095X320007	32	M8X1	5	8	14	10	51	125	47
W095X400007	40	M10X1	6	9.5	16.5	12	61	146	57
W095X500007	50	M12X1.5	6	11	20	14	75	158	62
W095X630007	63	M14X1.5	8	13	26	16	92	161	63

Note: 2- piece pack

SLIM SENSOR

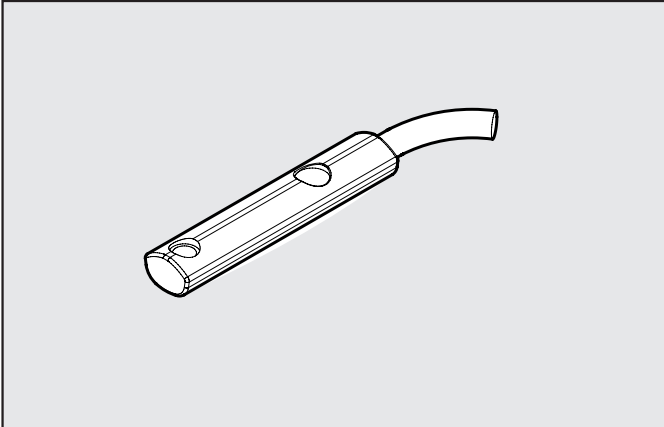

Code	Description
W0952025390	HALL N.O. SENSOR, VERTICAL INSERTION 2.5m
W0952029394	HALL N.O. SENSOR, VERTICAL INSERTION 300 mm M8
W0952022180	REED N.O. SENSOR, VERTICAL INSERTION 2.5m
W0952028184	REED N.O. SENSOR, VERTICAL INSERTION 300 mm M8
W0952125556	HALL N.O. SENSOR, VERTICAL INSERTION 2m ATEX

WIRING DIAGRAM

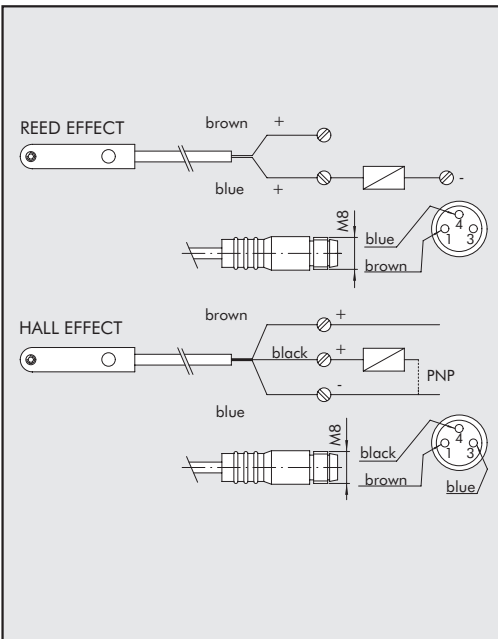

TECHNICAL DATA

	Reed	Effetto Hall	Effetto Hall
Type of contact	N.O.	N.O.	N.O.
Switch	-	PNP	PNP
Supply voltage (U _b)	V 10 ÷ 30 AC/DC	10 ÷ 30 DC	18 ÷ 30 DC
Power	W 3 (peak valve=6)	3	≤ 1.7
Voltage variation	-	≤ 10% di U _b	≤ 10% di U _b
Voltage drop	V -	≤ 2	≤ 2.2
Input current	mA -	≤ 10	≤ 10
Output current	mA ≤ 100	≤ 100	≤ 70
Switching frequency	Hz ≤ 400	≤ 5000	1000
Short-circuit protection	-	Yes	Yes
Over-voltage suppression	-	Yes	Yes
Polarity inversion protection	-	Yes	Yes
EMC	EN 60 947-5-2	EN 60 947-5-2	EN 60 947-5-2
LED display	Yellow	Yellow	Yellow
Magnetic sensitivity	2,8 mT ±25%	2,8 mT ±25%	2.6
Repeatability	≤ 0,1 mT	≤ 0,1 mT	≤ 0,1 (U _b and ta fixed)
Degree of protection (EN 60529)	IP 67	IP 67	IP 68, IP 69K
Vibration and shock resistance	30 g, 11 ms, 10÷55 Hz, 1mm	30 g, 11 ms, 10÷55 Hz, 1mm	30 g, 11 ms, 10÷55 Hz, 1mm
Temperature range	°C -25 ÷ +75	-25 ÷ +75	-20 ÷ +45
Sensor capsule material	PA66 + PA6I/6T	PA66 + PA6I/6T	PA
2.5m/2m connecting cable	PVC; 2 x 0,12 mm ²	PVC; 3 x 0,14 mm ²	PVC; 3 x 0,12 mm ²
Connecting cable with M8x1	Polyurethane; 2 x 0,14 mm ²	Polyurethane; 3 x 0,14 mm ²	-
Wire NO.	2	3	3

SENSOR CIRCLIP

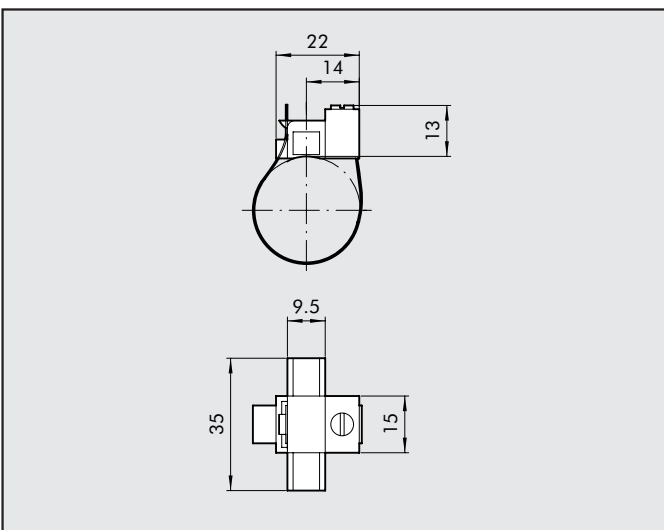

Codice	Alesaggio	Modello
W0950001103	8÷63	SENSOR CIRCLIP

Note: Individually packed

MATERIAL

Circlip: stainless steel
Sensor holder: plastic

DIMENSIONS OF DOUBLE-ACTING

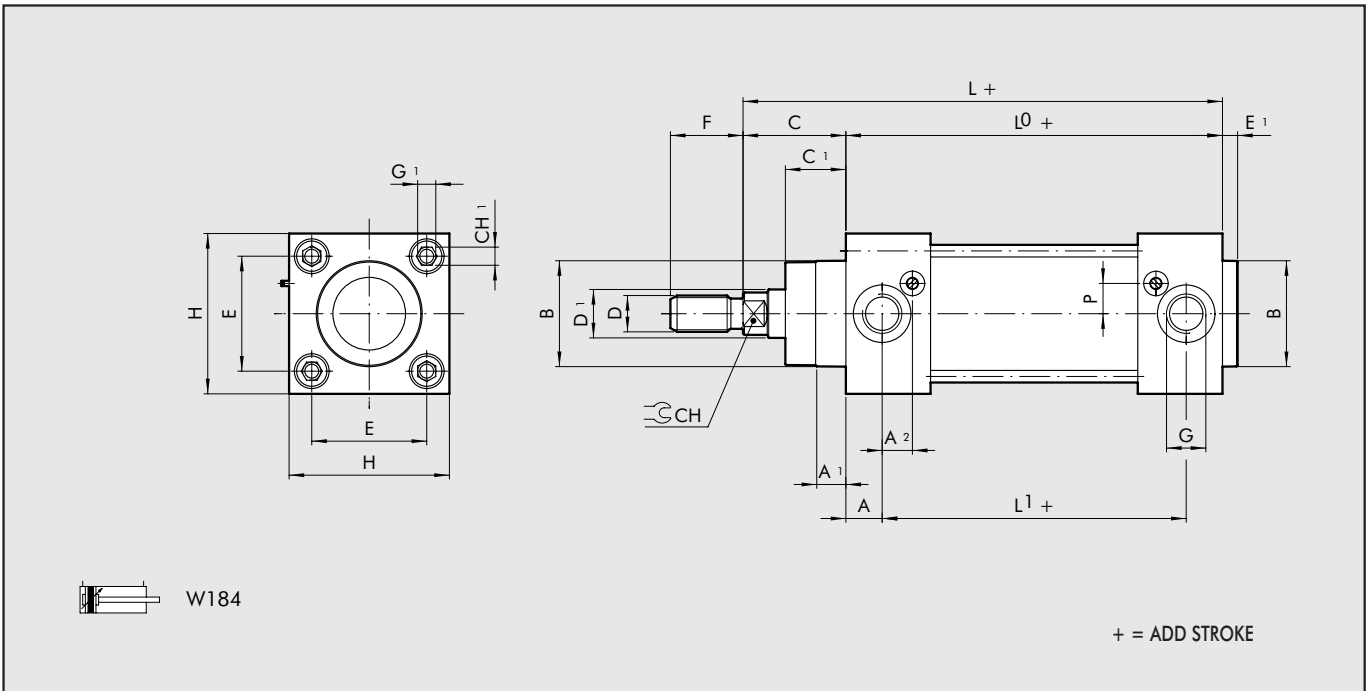

DIMENSIONS DOUBLE-ACTING THROUGH-ROD

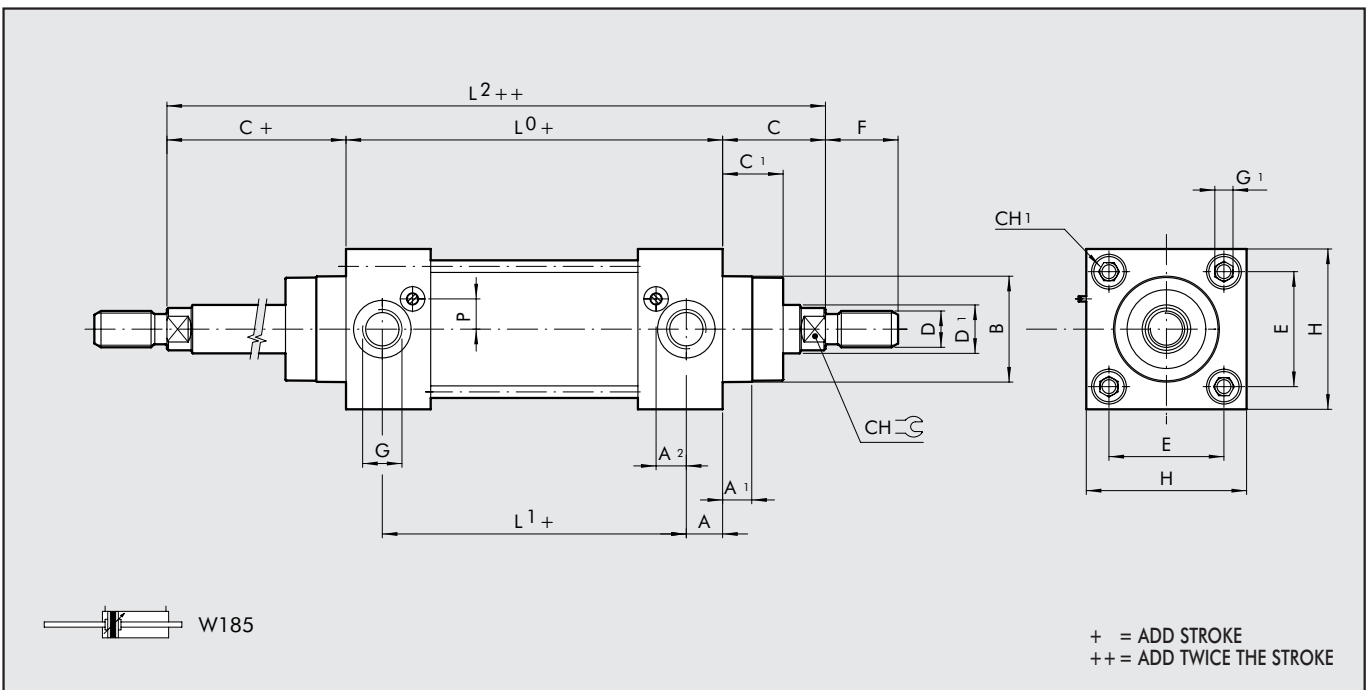

Ø.	A	A ₁	A ₂	B	C	C ₁	CH	CH ₁	D	D ₁	E	E ₁	F	G	G ₁	H	L	L ₀	L ₁	L ₂	P
32	14	9	11.3	30	26	18	10	6	M10x1.25	12	32.5	4	22	G1/8	M6	50	121	95	67	147	6
40	14	9	13	35	30	22	13	6	M12x1.25	16	38	4	24	G1/4	M6	55	135	105	77	165	8
50	14	9	12.7	40	37	25.5	16	8	M16x1.5	20	46.5	4	32	G1/4	M8	65	143	106	78	180	11.8
63	16	9	15.8	45	37	25	16	8	M16x1.5	20	56.5	4	32	G3/8	M8	75	158	121	89	195	11.7
80	16	9	16.3	45	46	35	21	10	M20x1.5	25	72	4	40	G3/8	M10	95	174	128	96	220	15.5
100	18	9	15.5	55	51	38	21	10	M20x1.5	25	89	4	40	G1/2	M10	110	189	138	102	240	15.5



KEY TO CODES

W 1 8	4	0	3 2	0 0 5 0
	TYPE	VERSION	DIAMETER	STROKE
Stainless steel cylinder	4 DEMA 5 DEMA through-rod	0 Magnetic S Standard (magnetic) V ● FKM/FPM gasket I Longer piston rod	32 40 50 63 80 A1=100	± Ø 32 ÷ 100 stroke 0 ÷ 1000 mm

DEMA: Magnetic double-acting (cushioned)

± Maximum recommended strokes. Higher values can create operating problems

● For this version the cylinder will be not magnetic

ACCESSORIES: FIXINGS

STAINLESS STEEL INTERMEDIATE HINGE - MODEL EN

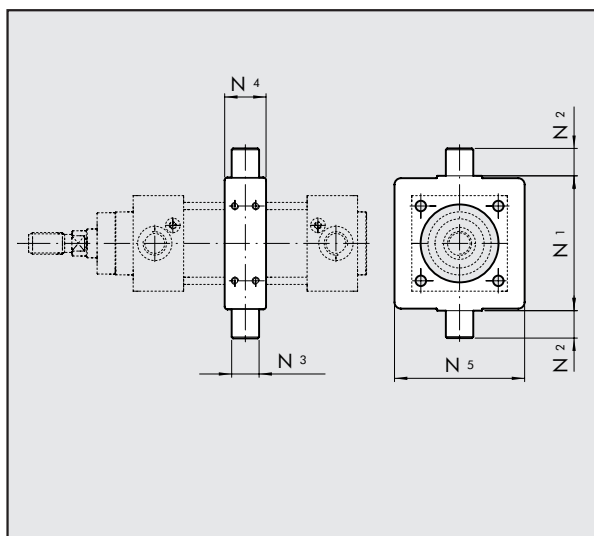

Code	Ø	N ₁	N ₂	N ₃	N ₄	N ₅
W095X322007	32	50	12	12	22	65
W095X402007	40	63	16	16	28	75
W095X502007	50	75	16	16	32	95
W095X632007	63	90	20	20	35	105
W095X802007	80	110	20	20	40	130
W095XA12007	100	132	25	25	45	145

Note: Supplied complete with 8 grub screws

STAINLESS STEEL SHORT FOOT MOUNTING

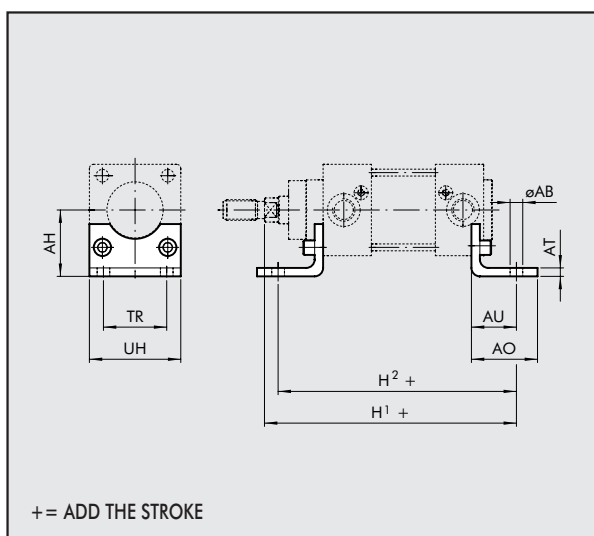

+ = ADD THE STROKE

Code	Ø	Ø AB	AH	AO	AT	AU	TR	UH	H ₁	H ₂
W095X322001	32	7	32	35	4	24	32	45	145	143
W095X402001	40	9	36	36	4	28	36	52	163	161
W095X502001	50	9	45	47	5	32	45	65	175	170
W095X632001	63	9	50	45	5	32	50	75	190	185
W095X802001	80	12	63	55	6	41	63	95	215	210
W095XA12001	100	14	71	57	6	41	75	115	230	220

Note: Individually packed with 2 screws.

STAINLESS STEEL FEMALE HINGE - MODEL B

Code Ø B D E ØG H₃ R S

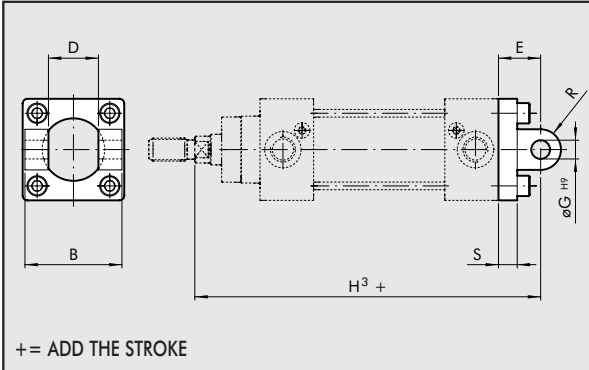

W095X322003	32	45	26	22	10	142	10	9
W095X402003	40	52	28	25	12	160	12	9
W095X502003	50	65	32	27	12	170	12	11
W095X632003	63	75	40	32	16	190	16	11
W095X802003	80	95	50	36	16	210	16	14
W095XA12003	100	115	60	41	20	230	20	14

Note: Supplied with 4 screws, 4 washers.
WITHOUT PIN.

FEMALE HINGE INOX PIN

Code Ø A B C D E

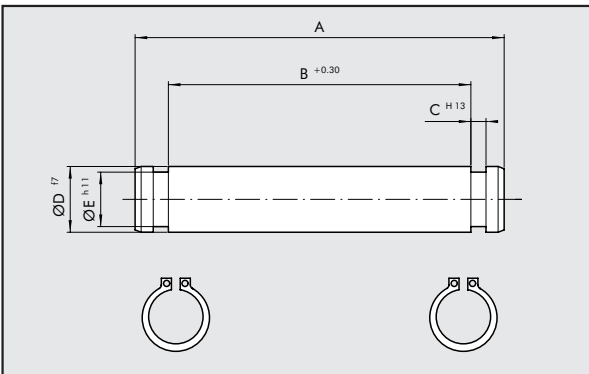

W095X322050	32	53	46	1.1	10	9.6
W095X402050	40	60	53	1.1	12	11.5
W095X502050	50	68	61	1.1	12	11.5
W095X632050	63	78	71	1.1	16	15.2
W095X802050	80	98	91	1.1	16	15.2
W095XA12050	100	118	111	1.3	20	19

Note: Supplied with 2 snap-rings

STAINLESS STEEL MALE HINGE - MODEL BA

Code Ø D E F ØG H H₃

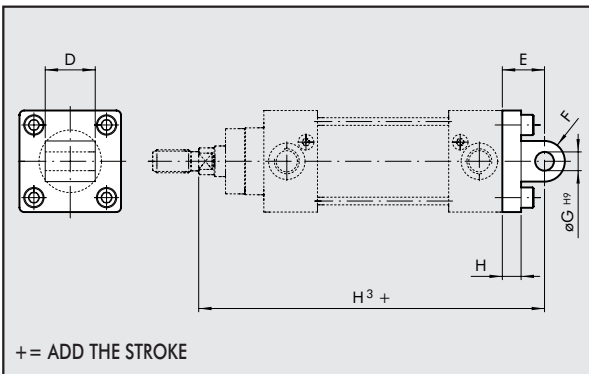

W095X322004	32	26	22	10	10	9	143
W095X402004	40	28	25	12	12	9	160
W095X502004	50	32	27	12	12	11	170
W095X632004	63	40	32	16	16	11	190
W095X802004	80	50	36	16	16	14	210
W095XA12004	100	60	41	20	20	14	230

Note: Supplied with 4 screws, 4 washers.

STAINLESS STEEL ISO COUNTER-HINGE FOR MODEL B - MODEL GS

Code Ø A B C D E F G H I L M N

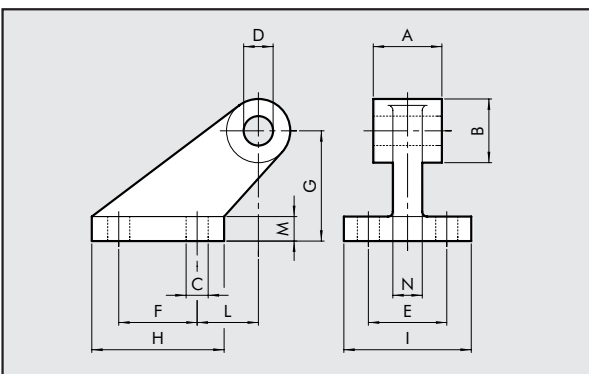

W095X322008	32	26	20	6.6	10	38	18	32	31	51	3	8	10
W095X402008	40	28	22	6.6	12	41	22	36	35	54	2	10	15
W095X502008	50	32	26	9	12	50	30	45	45	65	3	12	16
W095X632008	63	40	30	9	16	52	35	50	50	67	2	14	16
W095X802008	80	50	30	11	16	66	40	63	60	86	7	14	20
W095XA12008	100	60	38	11	20	76	50	71	70	96	5	17	20

Note: Individually packed



STAINLESS STEE FRONT FLANGE - MODEL C

Code Ø A A₁ B B₁ S ØD W

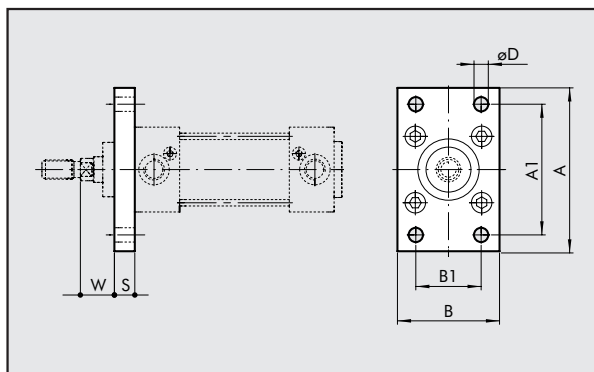

W095X322002	32	80	64	45	32	10	7	16
W095X402002	40	90	72	52	36	10	9	20
W095X502002	50	110	90	65	45	12	9	25
W095X632002	63	120	100	75	50	12	9	25
W095X802002	80	150	126	95	63	16	12	30
W095XA12002	100	170	150	115	75	16	14	35

Note: Supplied with 4 screws.

STAINLESS STEE REAR FLANGE - MODEL C

Code Ø A A₁ B B₁ S ØD L

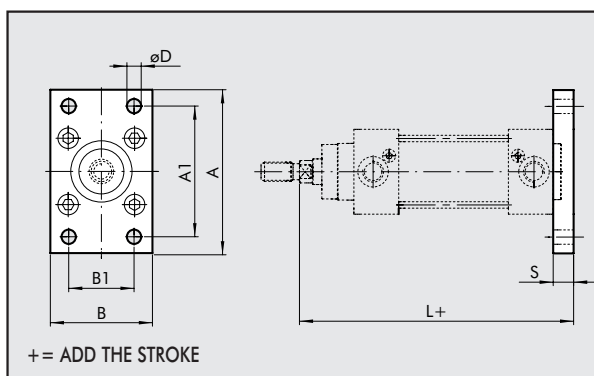

W095X322002	32	80	64	45	32	10	7	105
W095X402002	40	90	72	52	36	10	9	115
W095X502002	50	110	90	65	45	12	9	118
W095X632002	63	120	100	75	50	12	9	133
W095X802002	80	150	126	95	63	16	12	144
W095XA12002	100	170	150	115	75	16	14	154

Note: Supplied with 4 screws.

STAINLESS STEEL NUT FOR PISTON RODS

Code Ø F H CH Weight [g]

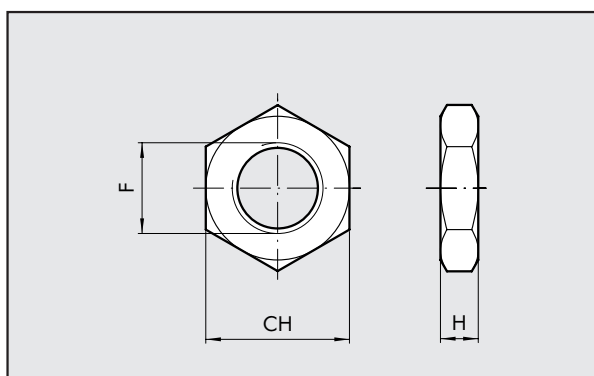

W095X322011	32	M10x1.25	6	17	6
W095X402011	40	M12x1.25	7	19	12
W095X502011	50	M16x1.5	8	24	20
W095X502011	63	M16x1.5	8	24	20
W095X802011	80	M20x1.5	9	30	32
W095X802011	100	M20x1.5	9	30	32

Note: Individually packed

STAINLESS STEEL FORK-MODEL GK-M

Code Ø A B C D F L Ø M

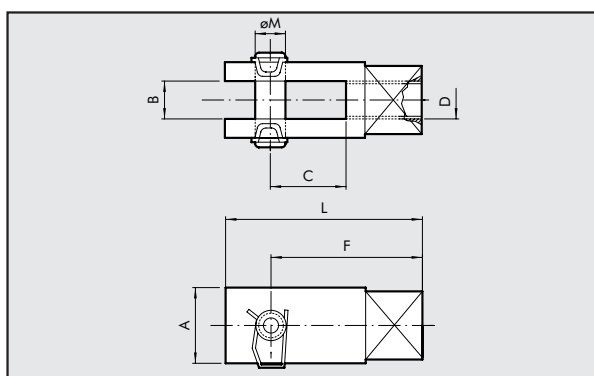

W095X322020	32	20	10	20	M10x1.25	40	52	10
W095X402020	40	24	12	24	M12x1.25	48	62	12
W095X502020	50	32	16	32	M16x1.5	64	83	16
W095X502020	63	32	16	32	M16x1.5	64	83	16
W095X802020	80	40	20	40	M20x1.5	80	105	20
W095X802020	100	40	20	40	M20x1.5	80	105	20

Note: Individually packed

ACCESSORIES: MAGNETIC SENSORS

SLIM SENSOR

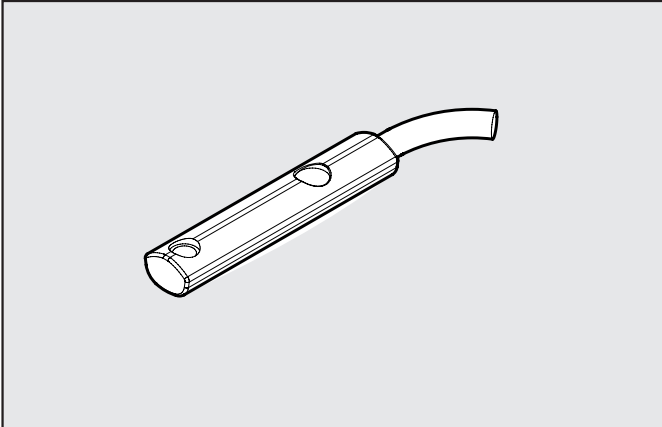

Code	Description
W0952025390	HALL N.O. SENSOR, VERTICAL INSERTION 2.5m
W0952029394	HALL N.O. SENSOR, VERTICAL INSERTION 300 mm M8
W0952022180	REED N.O. SENSOR, VERTICAL INSERTION 2.5m
W0952028184	REED N.O. SENSOR, VERTICAL INSERTION 300 mm M8
W0952125556	HALL N.O. SENSOR, VERTICAL INSERTION 2m ATEX

WIRING DIAGRAM

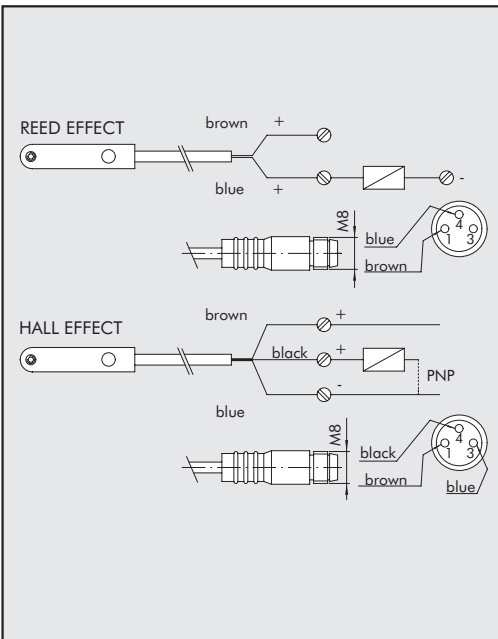

TECHNICAL DATA

	Reed	Effetto Hall	Effetto Hall
Type of contact	N.O.	N.O.	N.O.
Switch	-	PNP	PNP
Supply voltage (U _b)	V 10 ÷ 30 AC/DC	10 ÷ 30 DC	18 ÷ 30 DC
Power	W 3 (peak valve=6)	3	≤ 1.7
Voltage variation	-	≤ 10% di U _b	≤ 10% di U _b
Voltage drop	V -	≤ 2	≤ 2.2
Input current	mA -	≤ 10	≤ 10
Output current	mA ≤ 100	≤ 100	≤ 70
Switching frequency	Hz ≤ 400	≤ 5000	1000
Short-circuit protection	-	Yes	Yes
Over-voltage suppression	-	Yes	Yes
Polarity inversion protection	-	Yes	Yes
EMC	EN 60 947-5-2	EN 60 947-5-2	EN 60 947-5-2
LED display	Yellow	Yellow	Yellow
Magnetic sensitivity	2,8 mT ±25%	2,8 mT ±25%	2.6
Repeatability	≤ 0,1 mT	≤ 0,1 mT	≤ 0,1 (U _b and ta fixed)
Degree of protection (EN 60529)	IP 67	IP 67	IP 68, IP 69K
Vibration and shock resistance	30 g, 11 ms, 10÷55 Hz, 1mm	30 g, 11 ms, 10÷55 Hz, 1mm	30 g, 11 ms, 10÷55 Hz, 1mm
Temperature range	°C -25 ÷ +75	-25 ÷ +75	-20 ÷ +45
Sensor capsule material	PA66 + PA6I/6T	PA66 + PA6I/6T	PA
2.5m/2m connecting cable	PVC; 2 x 0,12 mm ²	PVC; 3 x 0,14 mm ²	PVC; 3 x 0,12 mm ²
Connecting cable with M8x1	Polyurethane; 2 x 0,14 mm ²	Polyurethane; 3 x 0,14 mm ²	-
Wire NO.	2	3	3

SENSOR BRACKET

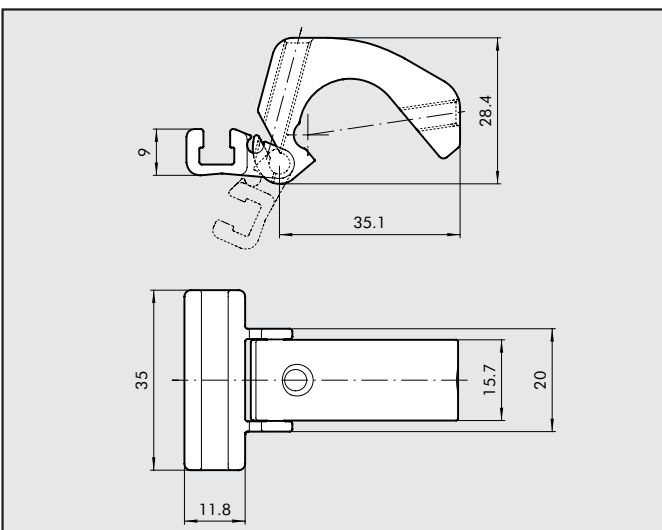

Codice	Modello	Alesaggio
W0950001100	SENSOR BRACKET	32 ÷ 100

Note: Individually packed

MATERIAL

Bracket: zinc-plated aluminium
 Sensor holder: zinc-plated aluminium
 Fixing screw: zinc-plated aluminium