

HYDRAULIC BRAKE SERIES BRK FOR ISO 15552 (EX ISO 6431) CYLINDER Ø 40-80 mm

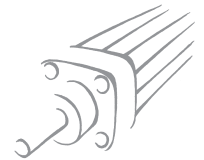

1

The hydraulic brake is the closed loop type without its own power source. It is normally linked to an ISO 15552 pneumatic cylinder. It consists of a cylinder full of oil, one or more flow regulation valves and a top-up tank to compensate for any oil leakage.

The following versions are available:

- With piston rod adjustment in either direction or both;
 - With SKIP valve (slow-fast) or stop valve or both.
- The compensation tank needs to be topped up from time to time. This should be done when the oil reaches the minimum level marked on the rod. With the piston rod right out, the stick must project not less than 20 mm from the tank cap. COMLUBE-DEXRON ATF oil should be used. During the first few cycles, any excess oil is ejected through a hole in the tank.

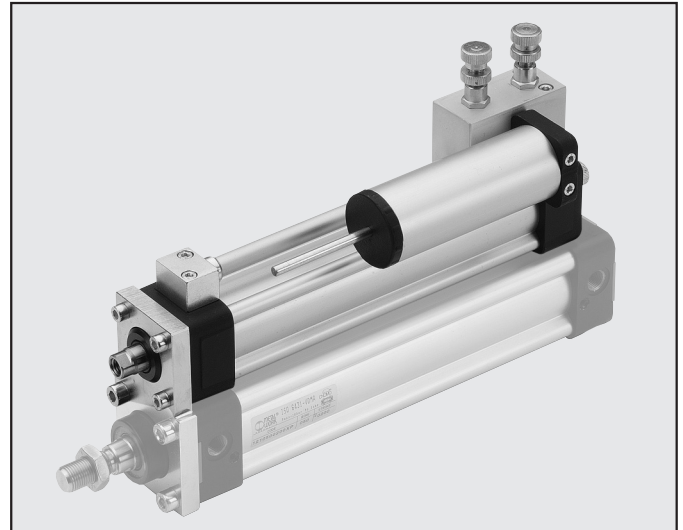

TECHNICAL DATA

Gaskets		NBR
Temperature range	T	-10°C to +70°C
Fluid		Filtered lubricated or unlubricated air. Lubrication, if used, must be continuous.
Adjustable load	F	6000N standard version 5000N with valves
Speed	V	10 mm/min. to 6000 mm/min.
Standard strokes	mm	50, 100, 150, 200, 250, 300, 350, 400, 450, 500 On request other special strokes, up to 1000
Configurations		Piston rod thrust adjustment; Piston rod retract adjustment Adjustment on both strokes; Thrust adjustment + skip valve Retract adjustment + skip valve; Double adjustment + double skip valve Thrust adjustment + stop valve; Retract adjustment + stop valve Twin adjustment + double stop valve; Thrust adjustment + skip/stop valve Retract adjustment + skip/stop valve
Fixing to cylinder		with flange kit
Connectable cylinders	mm	ISO 15552 cylinders with bores Ø 40 to Ø 80
Weights		See GENERAL TECHNICAL DATA PAGE 1.1./07

COMPONENTS

- ① PISTON ROD: thick chromed steel
- ② HEADS: die cast aluminium alloy
- ③ PISTON ROD GASKET: NBR rubber
- ④ PISTON ROD GUIDE BUSHING: steel strip with bronze and PTFE insert
- ⑤ JACKET: drawn anodised aluminium alloy
- ⑥ PISTON: aluminium alloy
- ⑦ PISTON GASKET: NBR rubber
- ⑧ OIL SEAL GASKET: polyurethane
- ⑨ Static O-rings: NBR rubber
- ⑩ SEALING DISK: plastic
- ⑪ SPRINGS: zinc-plated steel
- ⑫ SECURING/ASSEMBLY SCREW: Tap Tite screw
- ⑬ OIL LEVEL STICK: zinc-plated steel
- ⑭ OIL RECOVERY TANK
- ⑮ VALVE for OIL FILLING
- ⑯ FLOW REGULATION NEEDLE
- ⑰ MINIMUM LEVEL

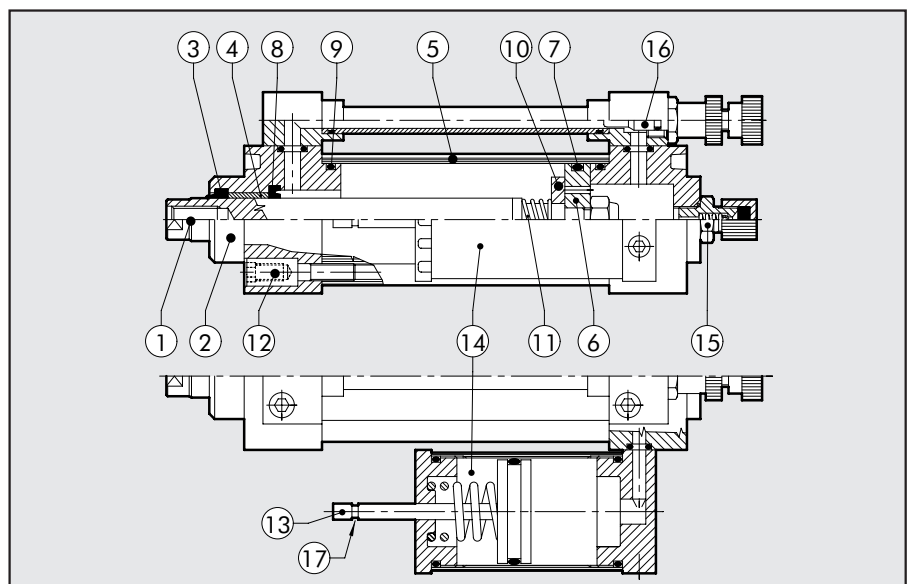

HYDRAULIC BRAKE + ISO 6431 CYLINDER Ø 40-80

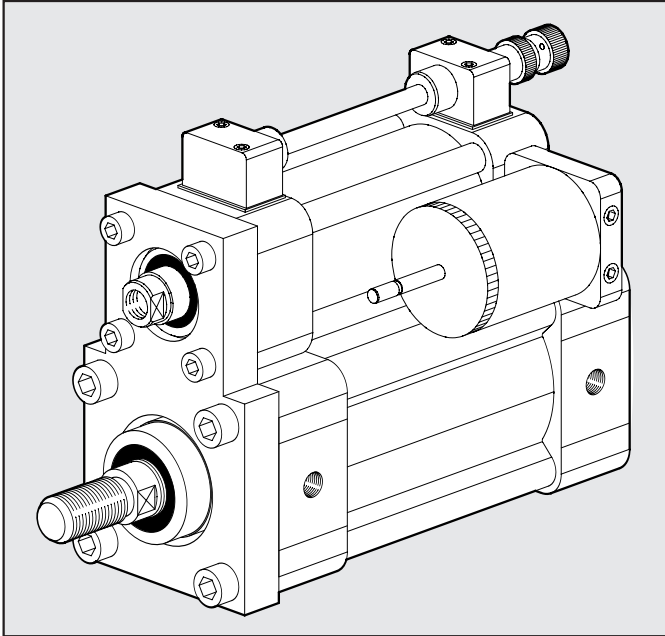

SKIP-STOP VALVE

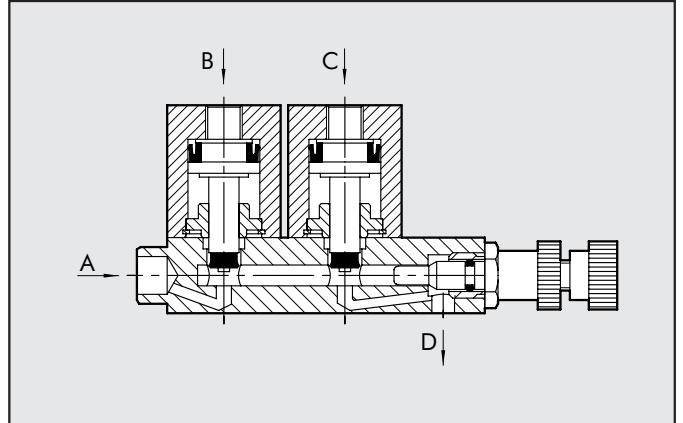

Both the skip valve and the stop valve are normally open and the fluid flows freely from A to D.
 With supply from port C, the skip valve is controlled and the fluid is forced to pass through a choke generated by the regulation pin.
 With supply from port B, the stop valve is controlled and the flow of fluid is interrupted.

DIMENSIONS OF HYDRAULIC BRAKE

Stroke	B	U
1÷50	90	28
51÷100	110	37
101÷150	110	44
151÷200	135	52
201÷250	135	60
251÷300	155	68
301÷350	155	77
351÷400	185	85
401÷450	185	92
451÷500	205	100

TYPE: BRK-P STD/SKV/STV/SKT

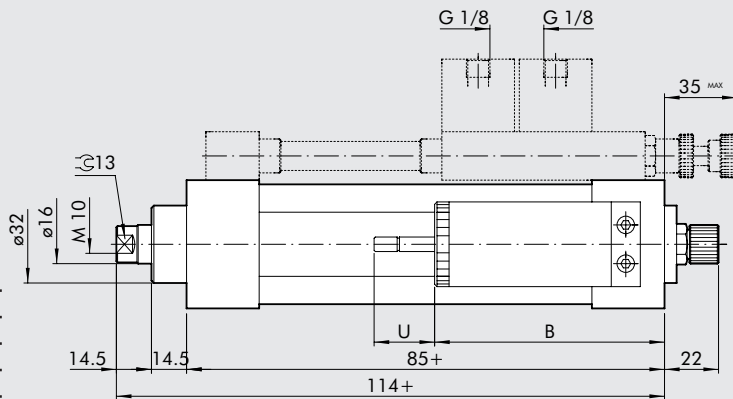

BRK-N STD/SKV/STV/SKT

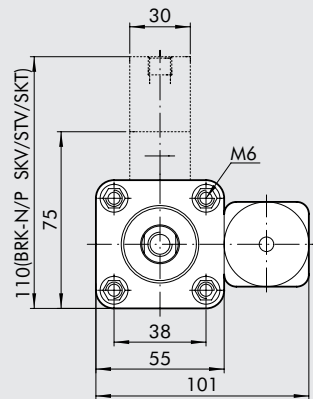

TYPE: BRK-D STD/STV/SKT

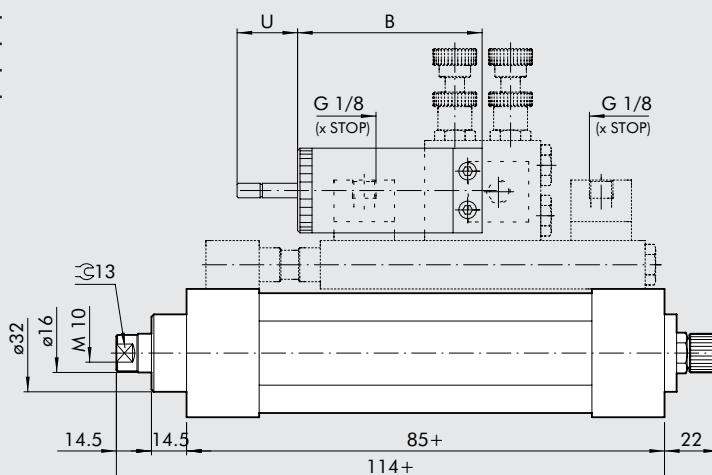

+ = ADD THE STROKE



HYDRAULIC BRAKE BRK-P STD.

Code

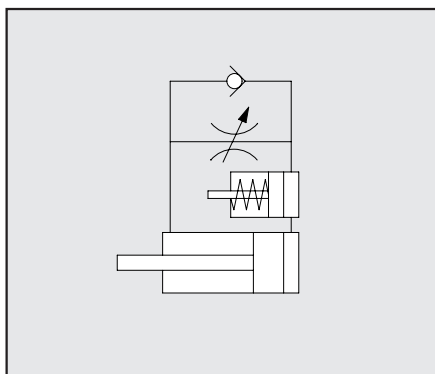
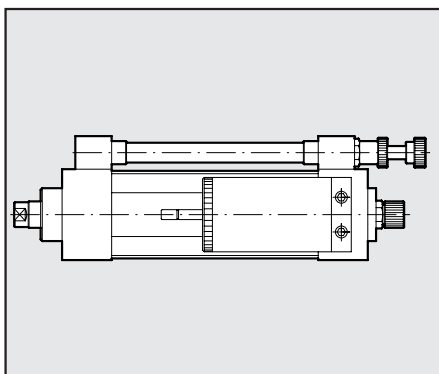

PISTON ROD THRUST ADJUSTMENT
W170001 ENTER THE STROKE

HYDRAULIC BRAKE BRK-N STD.

Code

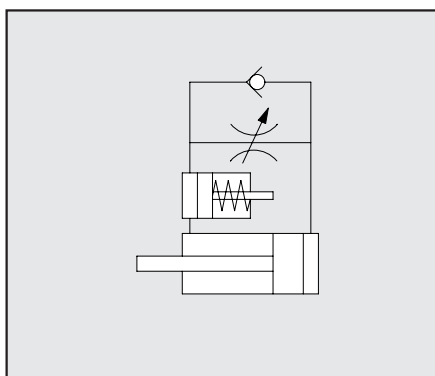
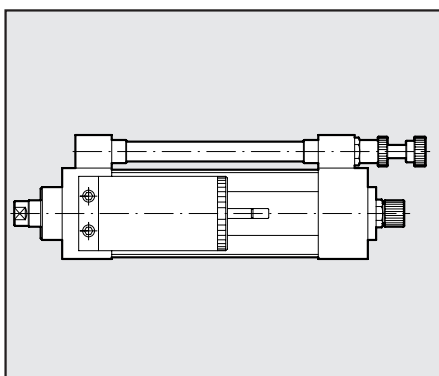

PISTON ROD RETRACT ADJUSTMENT
W170011 ENTER THE STROKE

HYDRAULIC BRAKE BRK-D STD

Code

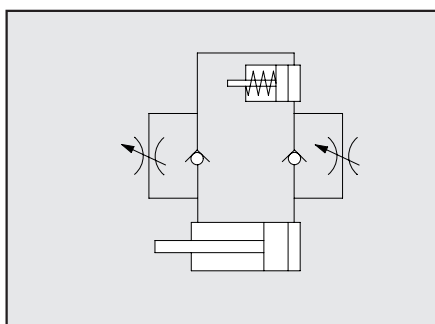
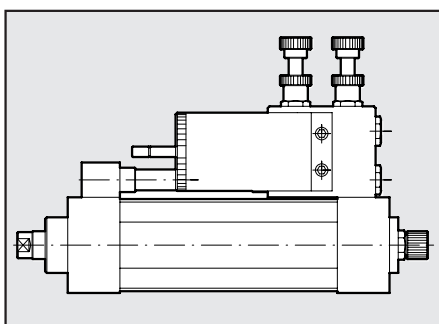

PISTON ROD RETRACT ADJUSTMENT
W170021 ENTER THE STROKE

HYDRULIAC BRAKE BRK-N SKV/BRK-N STV

Code

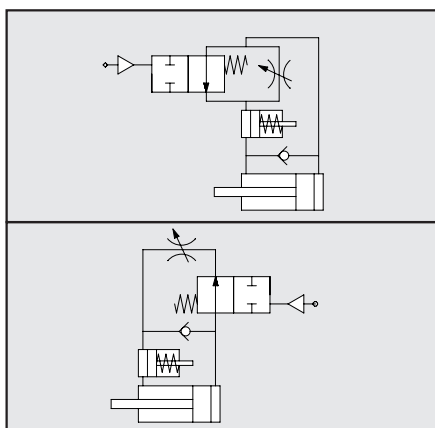
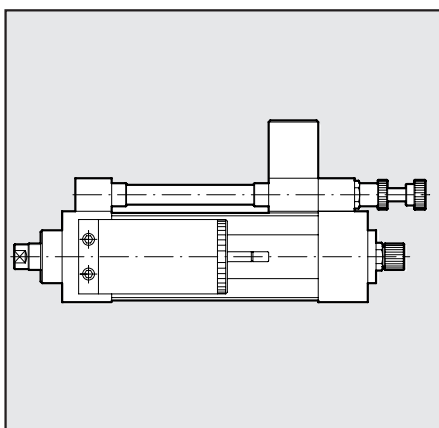

RETRACT ADJUSTMENT + SKIP VALVE
W170111 ENTER THE STROKE

RETRACT ADJUSTMENT + STOP VALVE
W170211 ENTER THE STROKE

HYDRAULIC BRAKE BRK-P SKV/BRK-P STV

Code

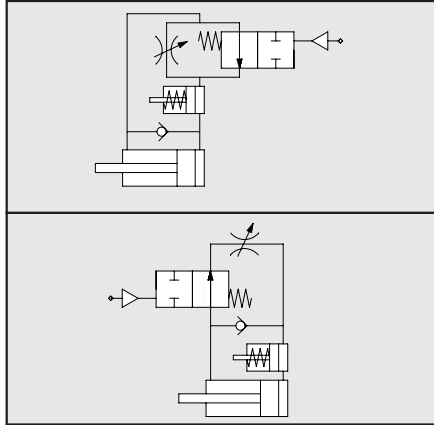
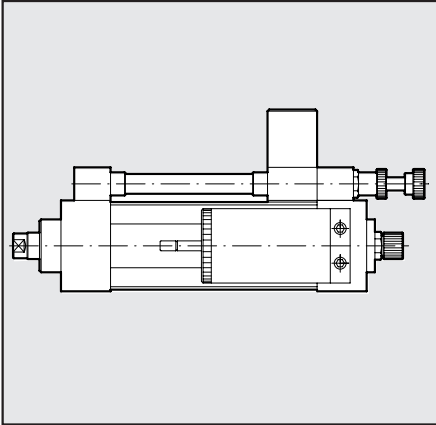

THRUST ADJUSTMENT + SKIP VALVE
W170101 ENTER THE STROKE

THRUST ADJUSTMENT+STOP VALVE
W170201 ENTER THE STROKE

HYDRAULIC BRAKE BRK-N SKT

Code

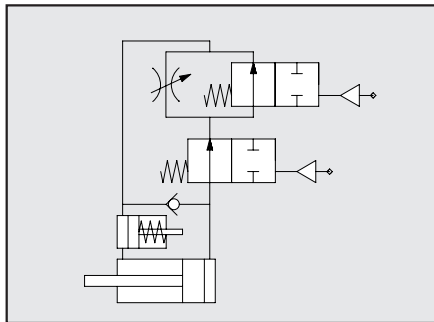
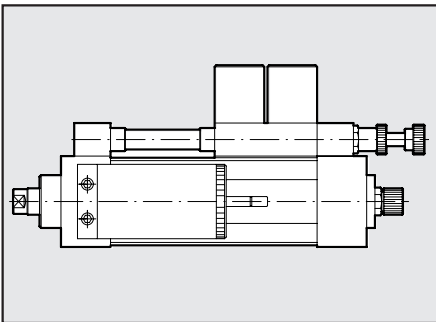

RETRACT ADJUSTMENT + SKIP/STOP VALVES
W170311 ENTER THE STROKE

HYDRAULIC BRAKE BRK-P SKT

Code

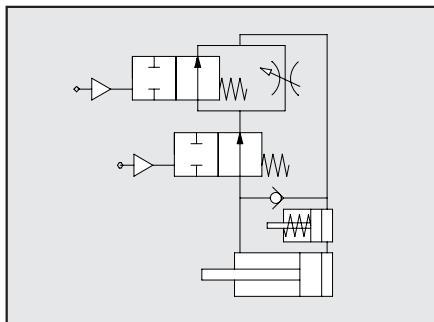
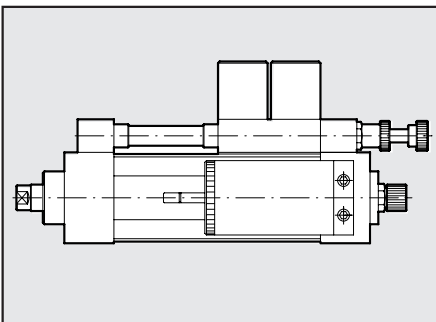

THRUST ADJUSTMENT + SKIP/STOP VALVE
W170301 ENTER THE STROKE

HYDRAULIC BRAKE BRK-D STV

Code

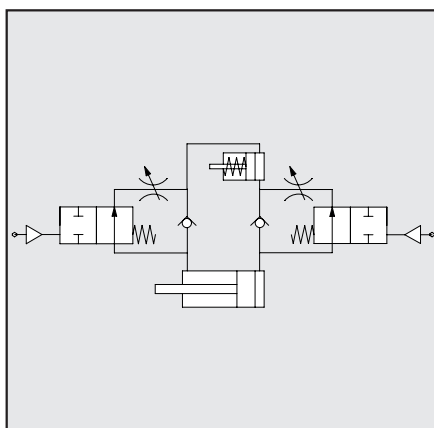
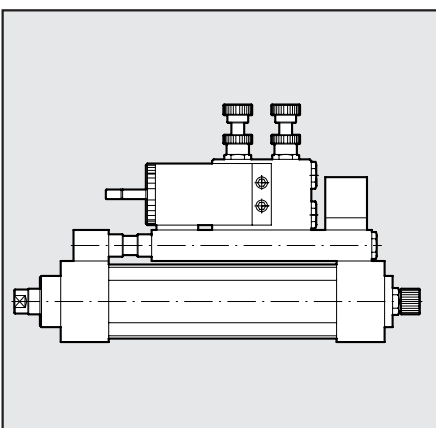

PISTON ROD THRUST RETRACT ADJUSTMENT
+ DOUBLE STOP VALVE
W170221 ENTER THE STROKE

NOTE: minimum stroke 150 mm

ACCESSORIES: FLANGE

FLANGE Ø 40

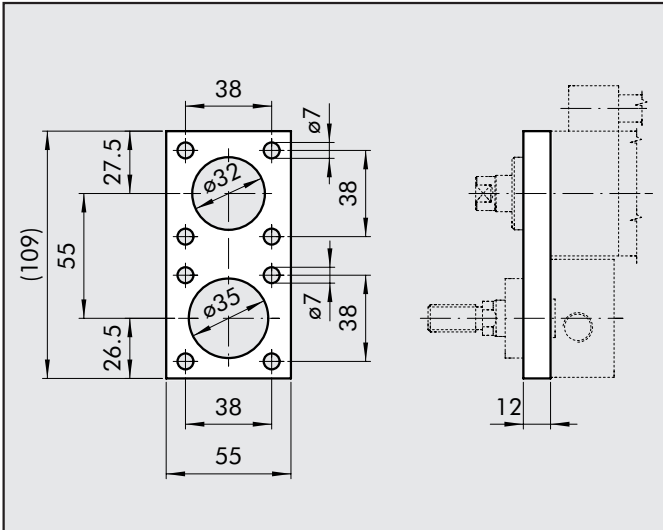

FLANGE Ø 50

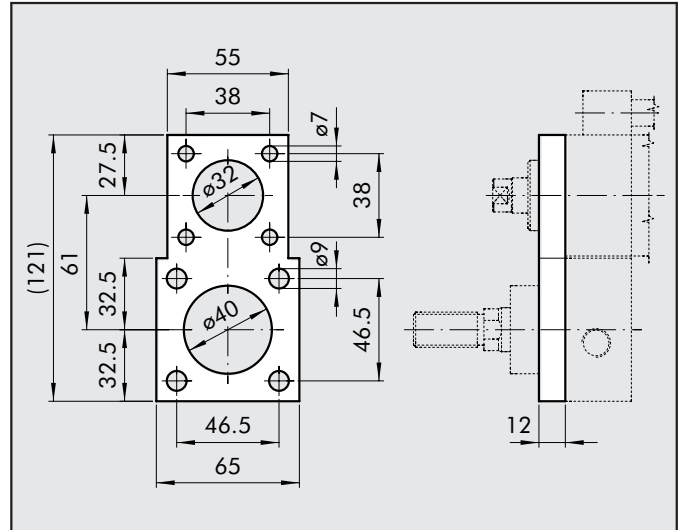

FLANGE Ø 63

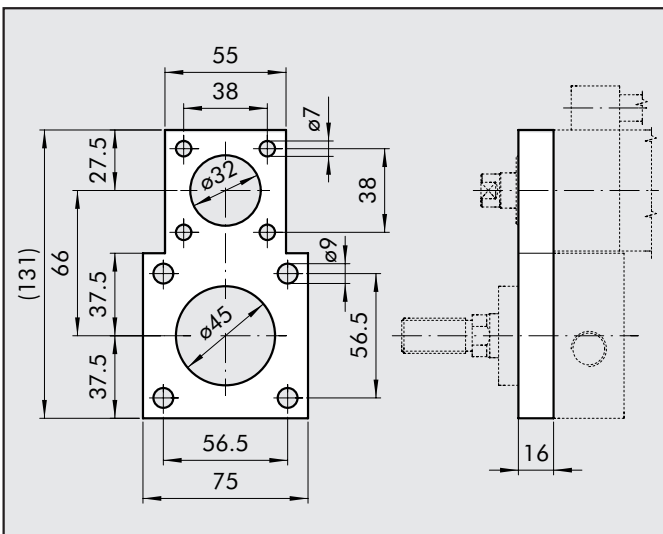

FLANGE Ø 80

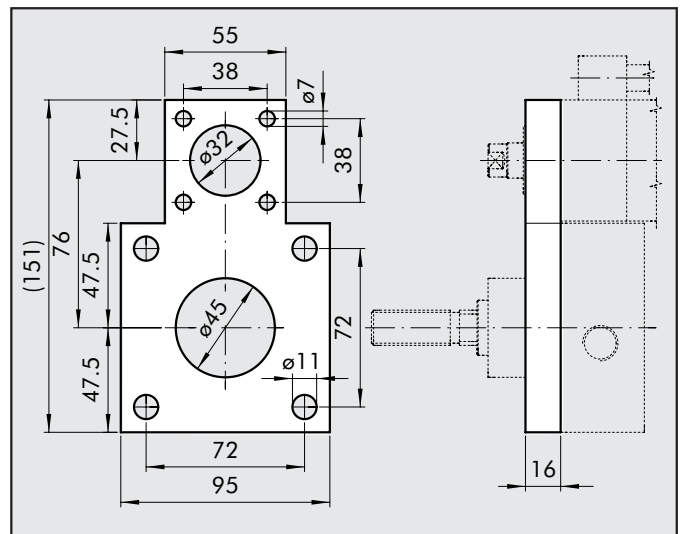

ORDERING CODES

Code	Description	Weight [g]
BRAKE CYLINDER CONNECTING FLANGE		
W0950402012	FLANGE ACC. MODEL CF-040	418
W0950502012	FLANGE ACC. MODEL CF-050	540
W0950632012	FLANGE ACC. MODEL CF-063	792
W0950802012	FLANGE ACC. MODEL CF-080	1216

Note: Supplied complete with 4+4 screws.

SET OF SCREWS FOR FLANGE

W0950402111	KIT BRK-P/C-040	58
W0950502111	KIT BRK-P/C-050	93
W0950632111	KIT BRK-P/C-063	97
W0950802111	KIT BRK-P/C-080	151

Note: the code corresponds to 4+4 screws.

NOTES