

# GUIDED COMPACT CYLINDERS

## Ø 16÷100

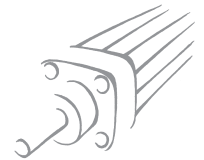

1

The guided compact cylinder series CMPG is a robust and practical solution with a built-in guide unit. The rod guiding bushes are mounted directly in the anodized aluminium alloy lining.

Two guiding solutions are available: sintered bronze bushes coupled with ground carbon chromed steel rods, or ball recirculation bushes coupled with tempered, chromed and ground steel rods.

There are grooves on one side of the body to house the retractable sensors.

In the non-cushioned version, the stop is silenced by NBR front gaskets, and the cushioned version has adjustable pins to graduate braking.

Threaded holes and calibrated holes are provided for fixing the dowel pins.

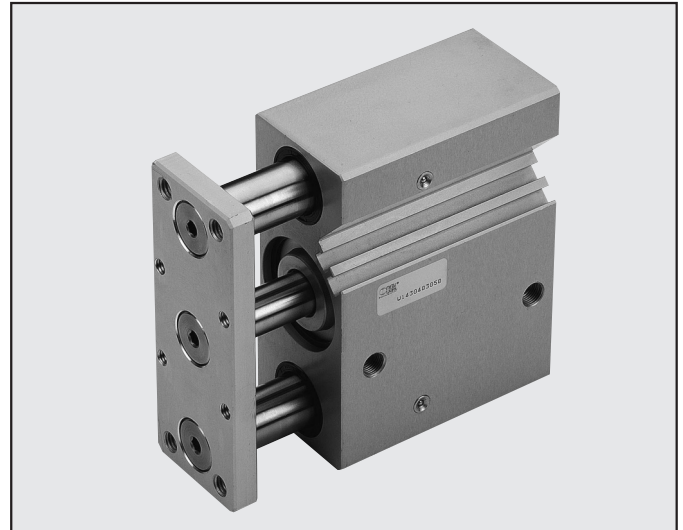

TECHNICAL DATA		CUSHIONED	NO-CUSHIONED
Operating pressure	bar	1 ÷ 10	
	MPa	0.1 ÷ 1	
Temperature range	psi	14.5 ÷ 145	
	°C	0 ÷ 80°C	
With dry air	°F	32 ÷ 176°F	
	°C	-20°	
Bores	°F	-4°	
	mm	Ø 16; 20; 25; 32; 40; 50; 63	Ø 16; 20; 25; 32; 40; 50; 63; 80; 100
Strokes		Ø16: 20-30-40-50	Ø16: 10-20-25*-30-40-50-75-100-150-200
		Ø20; Ø25: 20-30-40-50-75-100-150	Ø20; Ø25: 20-25*-30-40-50-75-100-150-200
		Ø32÷Ø63: 25-50-75-100-150-175	Ø32÷Ø100: 25-50-75-100-150-200
		Other strokes on request but with the same cylinder dimensions as the standard stroke immediately above.	
Version		With bronze bushings With ball bearings	
Weights		See GENERAL TECHNICAL DATA PAGE 1.1/07	
		* only bronze bushings version	

## COMPONENTS

- ① JACKET: anodized aluminium alloy
- ② PISTON ROD: grinded chrome steel
- ③ GUIDE ROD: grinded chrome steel
- ④ GUIDE ROD: hardened and tempered chrome steel
- ⑤ REAR BASE: anodized aluminium alloy
- ⑥ FRONT BASE: anodized aluminium alloy
- ⑦ GUIDE BUSHING: self-lubricating bronze
- ⑧ BUFFER GASKET: NBR
- ⑨ PISTON: aluminium alloy
- ⑩ MAGNET: plastoferrite
- ⑪ PISTON GASKET: (PARKER PRADIFA) NBR
- ⑫ GUIDE RING: PTFE
- ⑬ SLIDE BUSHING: sintered bronze
- ⑭ BALL BEARINGS
- ⑮ DUST SCRAPER RING: NBR or FKM/FPM
- ⑯ GREASE NIPPLES: zinc-plated or stainless steel

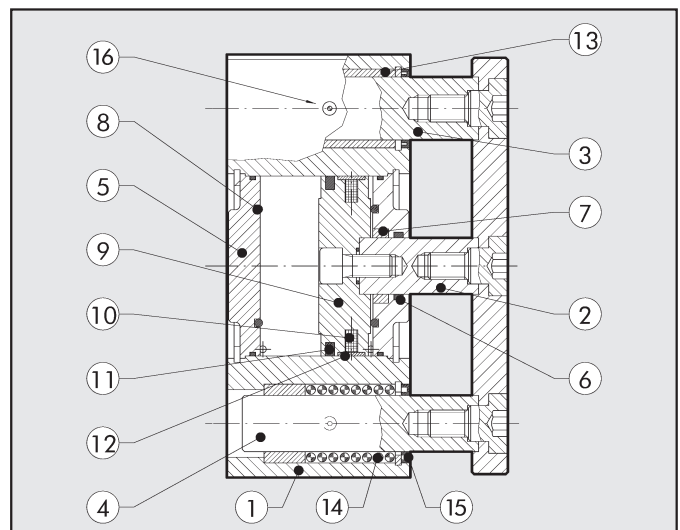

### MAXIMUM SIDE LOAD

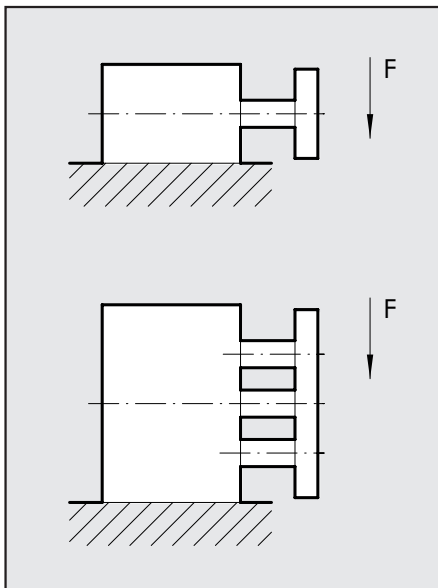

Ø mm	Guide unit	Stroke (mm)										
		10	20	25	30	40	50	75	100	150	175	200
16	Bushes	35	29	27	26	23	20	16	14	10	-	8
	Balls	29	31	-	27	38	34	29	24	12	-	8
20	Bushes	-	52	50	45	39	35	58	49	38	-	31
	Balls	-	56	-	48	79	70	54	50	27	-	32
25	Bushes	-	71	67	61	54	48	78	66	50	-	41
	Balls	-	72	-	62	78	73	60	52	37	-	30
32	Bushes	-	-	197	-	-	168	138	109	78	70	65
	Balls	-	-	89	-	-	60	276	217	138	122	110
40	Bushes	-	-	197	-	-	168	138	109	78	70	65
	Balls	-	-	89	-	-	60	276	217	138	122	110
50	Bushes	-	-	295	-	-	256	216	177	125	112	103
	Balls	-	-	138	-	-	89	393	314	184	163	148
63	Bushes	-	-	295	-	-	256	216	177	125	112	103
	Balls	-	-	138	-	-	89	393	314	184	163	148
80	Bushes	-	-	354	-	-	305	256	207	153	-	128
	Balls	-	-	236	-	-	158	864	687	413	-	335
100	Bushes	-	-	540	-	-	471	413	344	254	-	213
	Balls	-	-	471	-	-	314	1374	1074	629	-	511

NB: Forces are expressed in N

### MAXIMUM TORQUE ON PLATE

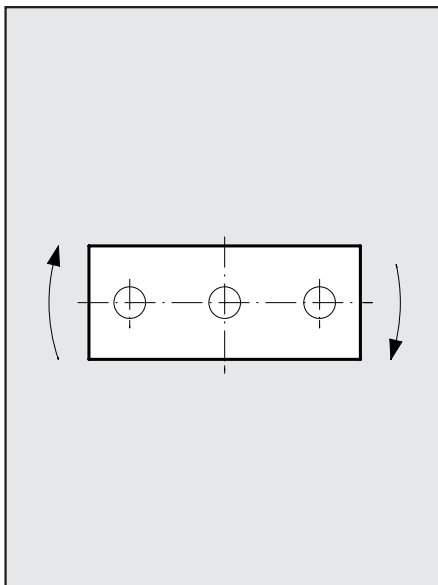

Ø mm	Guide unit	Stroke (mm)										
		10	20	25	30	40	50	75	100	150	175	200
16	Bushes	0.51	0.45	0.40	0.36	0.32	0.28	0.24	0.20	0.46	-	0.12
	Balls	0.74	0.60	-	0.50	0.72	0.65	0.54	0.45	0.35	-	0.25
20	Bushes	-	0.92	0.85	0.79	0.72	0.64	1.05	0.90	0.69	-	0.56
	Balls	-	1.28	-	1.08	1.78	1.59	1.24	1	0.61	-	0.49
25	Bushes	-	1.55	1.42	1.32	1.18	1.04	1.70	1.44	1.10	-	0.90
	Balls	-	1.98	-	1.70	2.16	2.20	1.66	1.4	1.02	-	0.82
32	Bushes	-	-	3.94	-	-	2.95	2.46	1.97	1.55	1.38	1.24
	Balls	-	-	1.97	-	-	1	2.96	2.44	2.40	2.43	2.18
40	Bushes	-	-	4.40	-	-	3.45	2.96	2.46	1.70	1.55	1.40
	Balls	-	-	2.46	-	-	1.45	6.38	5.4	3	2.73	2.40
50	Bushes	-	-	7.36	-	-	5.9	4.90	4.4	3	2.78	2.50
	Balls	-	-	3.45	-	-	2.44	10.8	8.35	4.5	4.06	3.60
63	Bushes	-	-	7.85	-	-	6.38	5.40	4.9	3.4	3.05	2.80
	Balls	-	-	3.94	-	-	2.46	11.77	9.3	5	4.46	4
80	Bushes	-	-	11.78	-	-	9.80	7.84	6.88	5.30	-	4.40
	Balls	-	-	9.34	-	-	5.88	31.38	24.5	10.40	-	11.7
100	Bushes	-	-	22.55	-	-	19.62	16.68	14.7	10.65	-	8.90
	Balls	-	-	21.56	-	-	13.73	63.72	49.1	26.6	-	21.6

NB: Forces are expressed in Nm

### ASSEMBLY OPTIONS

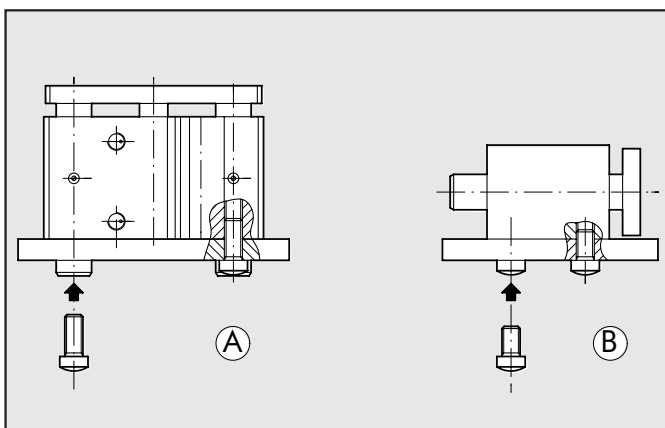

If the compact guided cylinder is mounted as shown in figure A, there need to be two through holes in the frame for the guide columns.



## STOPPER FUNCTIONS

1

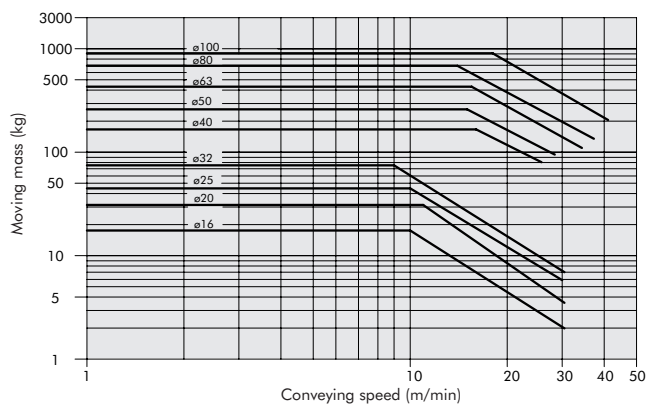
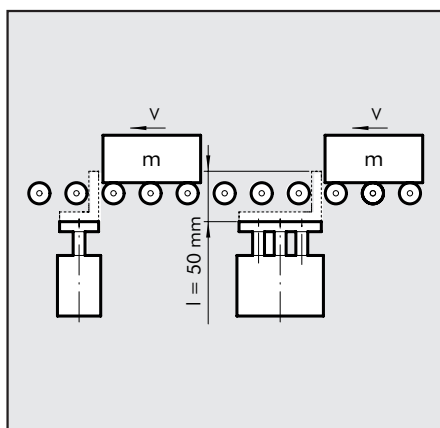

The graph refers to a 50mm-stroke cylinder.

## LIFTING FUNCTIONS

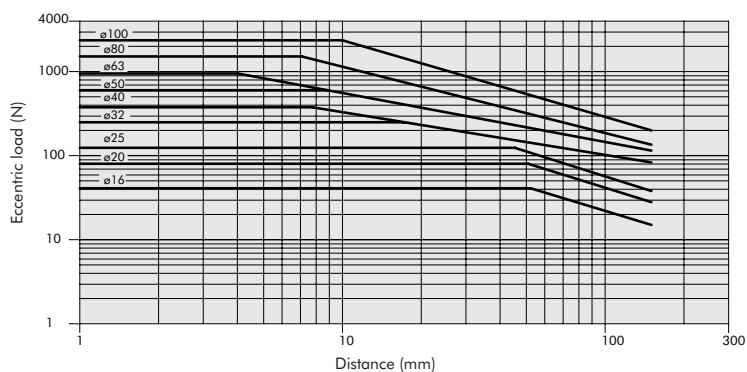
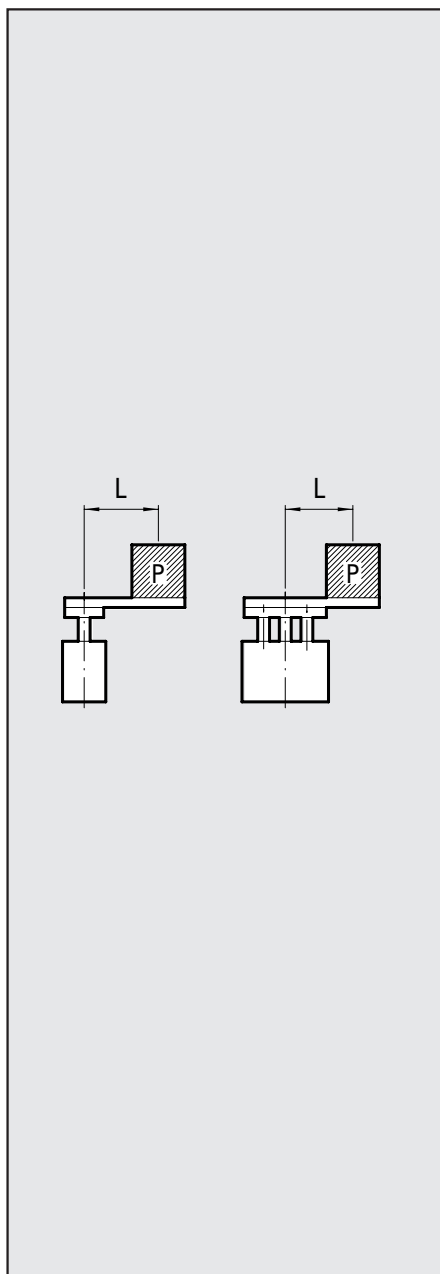

The graph refers from 25 to 50 mm-stroke cylinders with ball re-circulation guide unit.

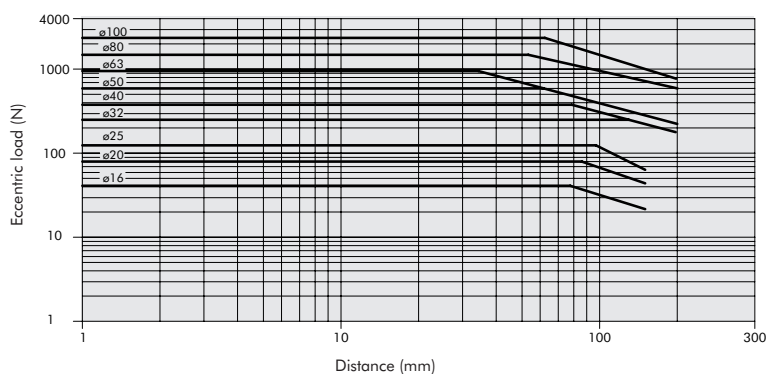

The graph refers from 75 to 100 mm-stroke cylinders with ball re-circulation guide unit.

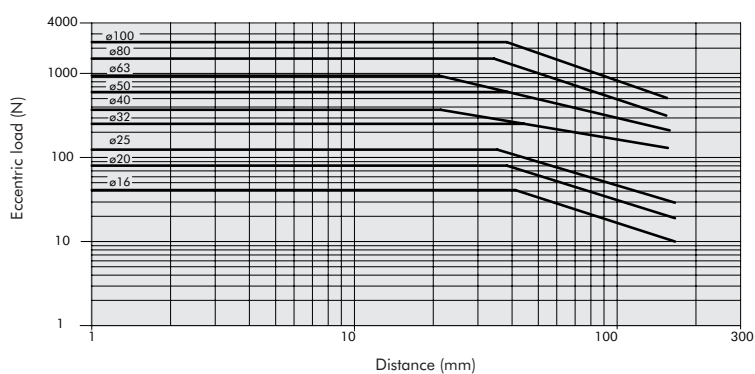

The graph refers to 50mm-stroke cylinders with bushing guide unit.

### DIMENSIONS OF NO-CUSHIONED COMPACT GUIDED CYLINDERS

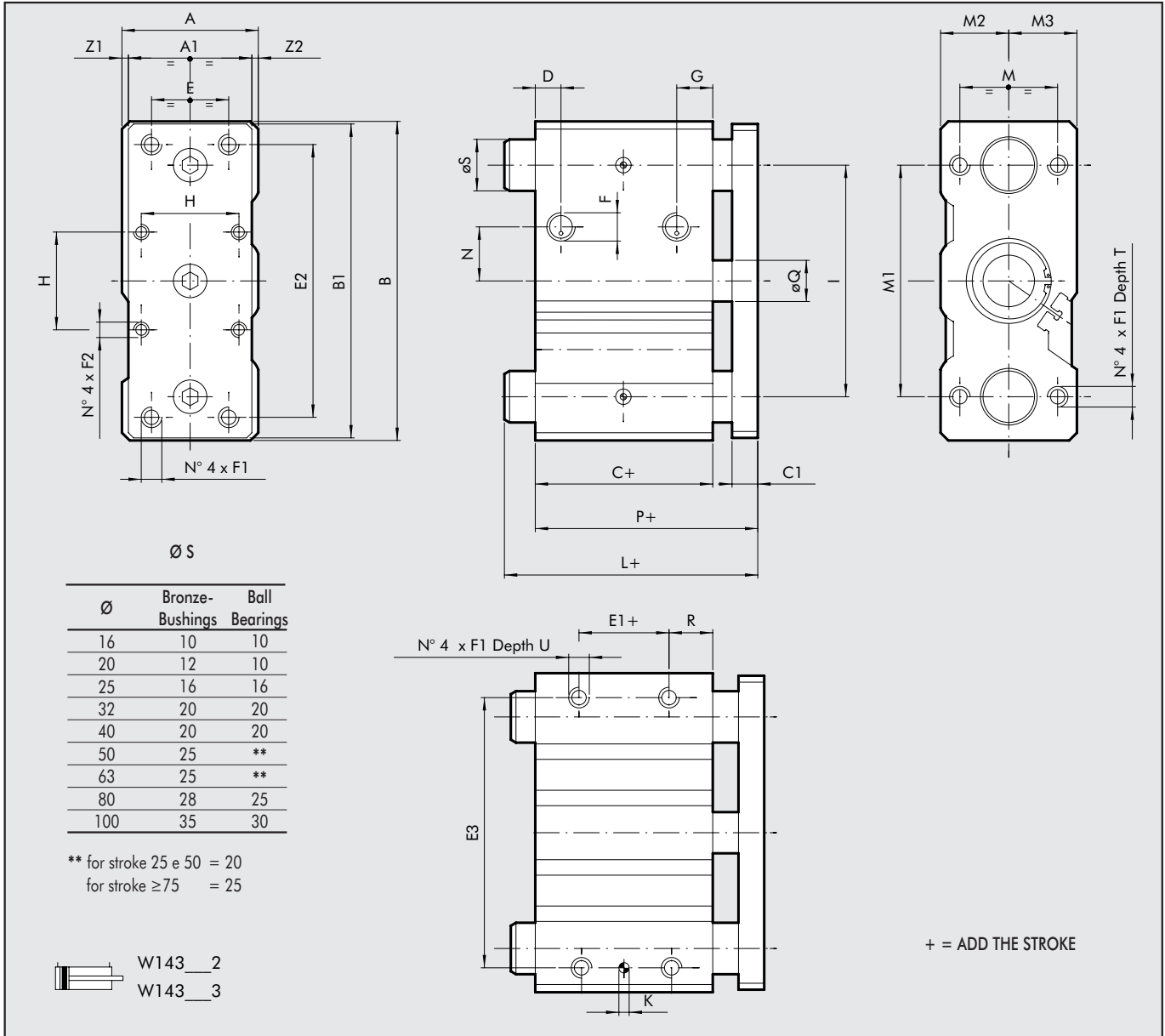

Ø	A	A1	B	B1	C	C1	D	E	E1	E2	E3	F	F1	F2	G	H	KH7	I	L	M	M1	M2	M3	N
16	33	25	64	62	33	10	9	16	7	52	54	M5	M5	-	10.5	-	4	38	*	22	42	15	18	8
20	36	29	74	72	37	10	9	18	10	60	64	1/8	M5	-	11	-	5	46	*	26	52	17	19	9
25	42	38	88	86	37.5	10	9	26	10	70	76	1/8	M6	-	11.5	-	5	56	*	32	62	21	21	8
32	51	49	114	112	37.5	10	9	30	5	96	100	1/8	M8	M6	12.5	32.5	6	80	73.5	38	80	25.5	25.5	15
40	51	49	124	122	44	10	11	30	10	106	110	1/8	M8	M6	14	38	6	90	73.5	38	90	25.5	25.5	21
50	59	56	140	138	44	12	11	40	10	120	124	1/4	M10	M8	14	46.5	6	100	83	44	100	29.5	29.5	27
63	72	69	150	148	49	12	11	50	10	130	132	1/4	M10	M8	14	56.5	6	110	83	44	110	36	36	31.5
80	92	88	188	185	56.5	16	15.5	60	15	160	166	3/8	M12	M10	19	72	6	140	93	56	140	46	46	37
100	112	108	224	221	66	16	19	80	15	190	200	3/8	M14	M10	23	89	8	170	105	62	170	56	56	40

Ø	P	ØQ	R	T	U	Z1	Z2
16	45	8	13	20	8	5.5	2.5
20	49	10	13	20	8	4.5	2.5
25	49.5	12	16.5	25	9	2	2
32	49.5	16	16	20	11	1.5	1.5
40	56	16	17	20	11	1.5	1.5
50	58	20	17	25	12.5	1.5	1.5
63	63	20	20	25	15	1.5	1.5
80	74.5	25	21	30	18	2	2
100	84	30	25	35	21	2	2

* =	L stroke	
Ø	0÷50	75÷200
16	45	-
20	49	76
25	49.5	79.5



## DIMENSIONS OF CUSHIONED COMPACT GUIDED CYLINDERS

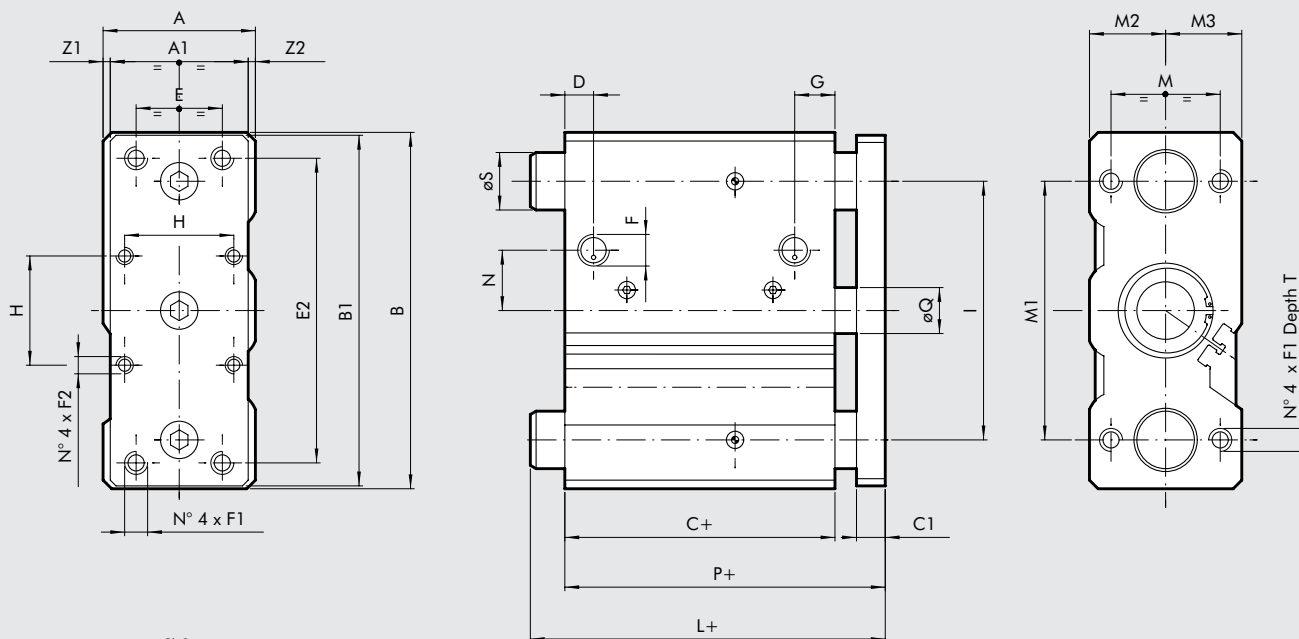

Ø S		
Ø	Bronze-Bushings	Ball Bearings
16	10	10
20	12	10
25	16	16
32	20	20
40	20	20
50	25	**
63	25	**

\*\* for stroke 25 e 50 = 20  
for stroke ≥75 = 25

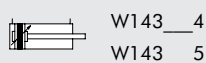

W143\_4  
W143\_5

+ = ADD THE STROKE

Ø	A	A1	B	B1	C	C1	D	E	E1	E2	E3	F	F1	F2	G	H	KH7	I	L	M	M1	M2	M3	N
16	33	25	64	62	58	10	9	16	32	52	54	M5	M5	-	10.5	-	4	40	*	22	42	15	18	8
20	36	29	74	72	62	10	9	18	35	60	64	1/8	M5	-	11	-	5	46	*	26	52	17	19	9
25	42	38	88	86	62.5	10	9	26	35	70	76	1/8	M6	-	11.5	-	5	56	*	32	62	21	21	8
32	51	49	114	112	62.5	10	9	30	30	96	100	1/8	M8	M6	12.5	32.5	6	80	106.5	38	80	25.5	25.5	15
40	51	49	124	122	69	10	11	30	35	106	110	1/8	M8	M6	14	38	6	90	106.5	38	90	25.5	25.5	21
50	59	56	140	138	69	12	11	40	35	120	124	1/4	M10	M8	14	46.5	6	100	118	44	100	29.5	29.5	27
63	72	69	150	148	74	12	11	50	35	130	132	1/4	M10	M8	14	56.5	6	110	118	44	110	36	36	31.5

Ø	P	ØQ	R	T	U	Z1	Z2
16	◆	8	13	20	8	5.5	2.5
20	78	10	13	20	8	4.5	2.5
25	78.5	12	14	25	9	2	2
32	82.5	16	16.5	20	11	1.5	1.5
40	89	16	17	20	11	1.5	1.5
50	93	20	17	25	12.5	1.5	1.5
63	98	20	20	25	15	1.5	1.5

◆ for bronze bushings = 78  
for ball bearing = 75

* =	L stroke	
Ø	0÷50	75÷150
16	70	-
20	74	105.5
25	74.5	108.5

## KEY TO CODES

W 1 4 3	0 3 2	2	0 2 5
TYPE	DIAMETER	VERSION	STROKE
	16 20 25 32 40 50 63 *80 *A1=100	2 bronze bushings 3 ball bearings 4 cushioned with brass bushings 5 cushioned with ball bearings	<b>CUSHIONED VERSION</b> Ø 16: 20, 30, 40, 50 Ø 20÷25: 20, 30, 40, 50, 75, 100, 150 Ø 32÷63: 25, 50, 75, 100, 150, 175 <b>NOT CUSHIONED VERSION</b> ♦ Ø 16: 10, 20, ●25, 30, 40, 50, 75, 100, 150, 200 Ø 20÷25: 20, ●25, 30, 40, 50, 75, 100, 150, 200 Ø 32÷100: 25, 50, 75, 100, 150, 200 ♦ Other strokes on request but with the same cylinder dimensions as the standard stroke immediately above.

\* Not cushioned version only  
● Bronze bushings version only

## ACCESSORIES

### RETRACTABLE SENSOR WITH INSERTION FROM ABOVE

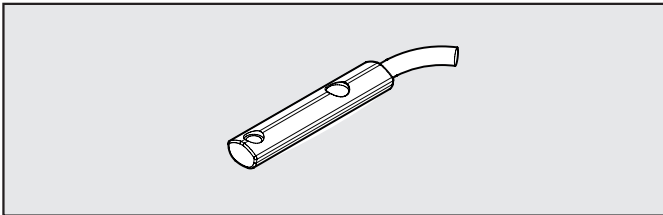

Code	Description
W0952025390	HALL N.O. SENSOR, VERTICAL INSERTION 2.5m
W0952029394	HALL N.O. SENSOR, VERTICAL INSERTION 300 mm M8
W0952022180	REED N.O. SENSOR, VERTICAL INSERTION 2.5m
W0952028184	REED N.O. SENSOR, VERTICAL INSERTION 300 mm M8
W0952125556	HALL N.O. SENSOR, VERTICAL INSERTION 2m ATEX

This type of sensor can be inserted in the slot of the sensor from above. This means the cylinder heads do not require a through opening.

### WIRING DIAGRAM

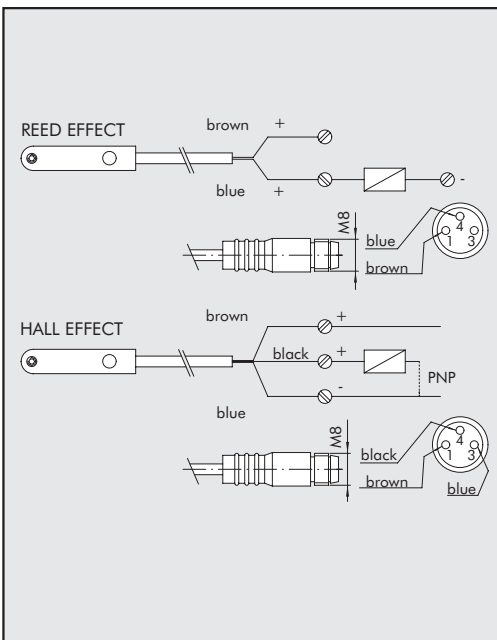

### TECHNICAL DATA

	Reed	Effetto Hall	Effetto Hall
Type of contact	N.O.	N.O.	N.O.
Switch	-	PNP	PNP
Supply voltage (Ub)	V 10 ÷ 30 AC/DC	10 ÷ 30 DC	18 ÷ 30 DC
Power	W 3 (peak valve=6)	3	≤ 1.7
Voltage variation	-	≤ 10% di Ub	≤ 10% di Ub
Voltage drop	V -	≤ 2	≤ 2.2
Input current	mA -	≤ 10	≤ 10
Output current	mA ≤ 100	≤ 100	≤ 70
Switching frequency	Hz ≤ 400	≤ 5000	1000
Short-circuit protection	-	Yes	Yes
Over-voltage suppression	-	Yes	Yes
Polarity inversion protection	-	Yes	Yes
EMC	EN 60 947-5-2	EN 60 947-5-2	EN 60 947-5-2
LED display	Yellow	Yellow	Yellow
Magnetic sensitivity	2,8 mT ±25%	2,8 mT ±25%	2.6
Repeatability	≤ 0,1 mT	≤ 0,1 mT	≤ 0,1 (Ub and ta fixed)
Degree of protection (EN 60529)	IP 67	IP 67	IP 68, IP 69K
Vibration and shock resistance	30 g, 11 ms, 10÷55 Hz, 1mm	30 g, 11 ms, 10÷55 Hz, 1mm	30 g, 11 ms, 10÷55 Hz, 1mm
Temperature range	°C -25 ÷ +75	-25 ÷ +75	-20 ÷ +45
Sensor capsule material	PA66 + PA6I/6T	PA66 + PA6I/6T	PA
2.5m/2m connecting cable	PVC; 2 x 0,12 mm <sup>2</sup>	PVC; 3 x 0,14 mm <sup>2</sup>	PVC; 3 x 0,12 mm <sup>2</sup>
Connecting cable with M8x1	Polyurethane; 2 x 0,14 mm <sup>2</sup>	Polyurethane; 3 x 0,14 mm <sup>2</sup>	-
Wire NO.	2	3	3

### BAR FOR GROOVING

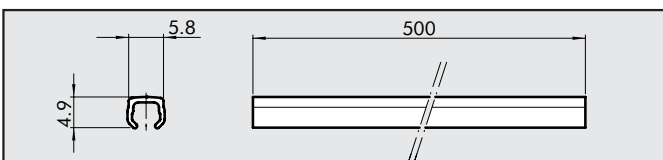

Code	Description
W0950000160	BAR FOR GROOVING L=500 mm

Note: the code corresponds to 1 piece