



SLIDE VALVES, Series VCS

SLIDE VALVES

The 3/2 slide valve is normally used as a circuit on-off valve. When the ring nut is moved back, the system downstream is relieved; when the ring nut is moved forward, the system is supplied with compressed air.



TECHNICAL DATA	1/8"	1/4"	3/8"	1/2"	
Operating pressure	0 ÷ 10 bar (0 ÷ 1 MPa)				
Operating temperature range	-10 ÷ 80°C				
Fluid	Lubricated or unlubricated filtered air				
Flow rate at 6.3 bar (0.63 Mpa ÷ 91 psi) ΔP 0.5 bar	NI/min	430	680	1400	2200
Flow rate at 6.3 bar (0.63 Mpa ÷ 91 psi) ΔP 1 bar	NI/min	630	1040	2070	3330
Conductance C	[NI/min · bar]	170	247	537	833
Critical ratio b	bar/bar	0.2	0.3	0.1	0.2

COMPONENTS

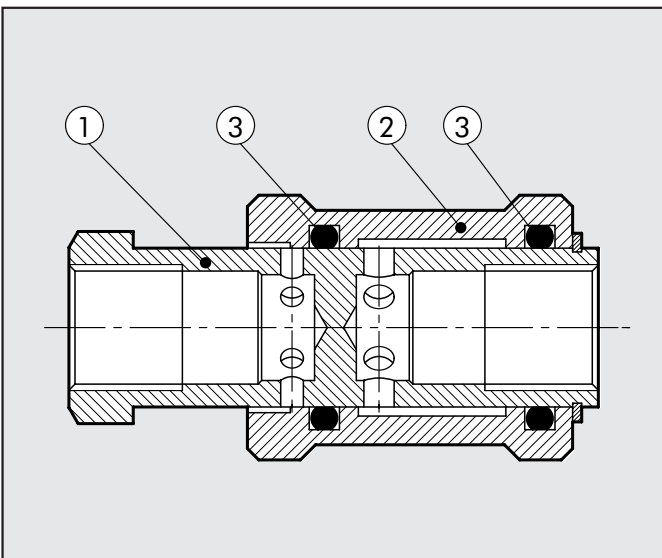

- ① Body: chromium-plated brass
- ② Ring nut: anodized aluminium
- ③ Seals: NBR

DIMENSIONS AND ORDERING CODES

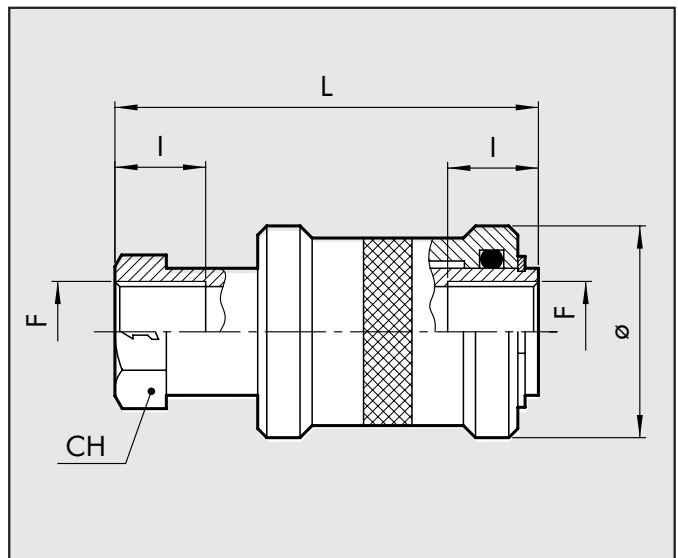

Code	Description	F	Ø	I	L	CH
W0970050001	SLIDE VALVES 3/2	1/8"	25	10	48	11
W0970050002	SLIDE VALVES 3/2	1/4"	30	12	58	19
W0970050003	SLIDE VALVES 3/2	3/8"	35	12	68	22
W0970050004	SLIDE VALVES 3/2	1/2"	40	15	80	27